

# Webster<sup>®</sup> Fuel Pumps & Valves

## Pump/Motor Units

Bulletin FU41-9  
April, 2008

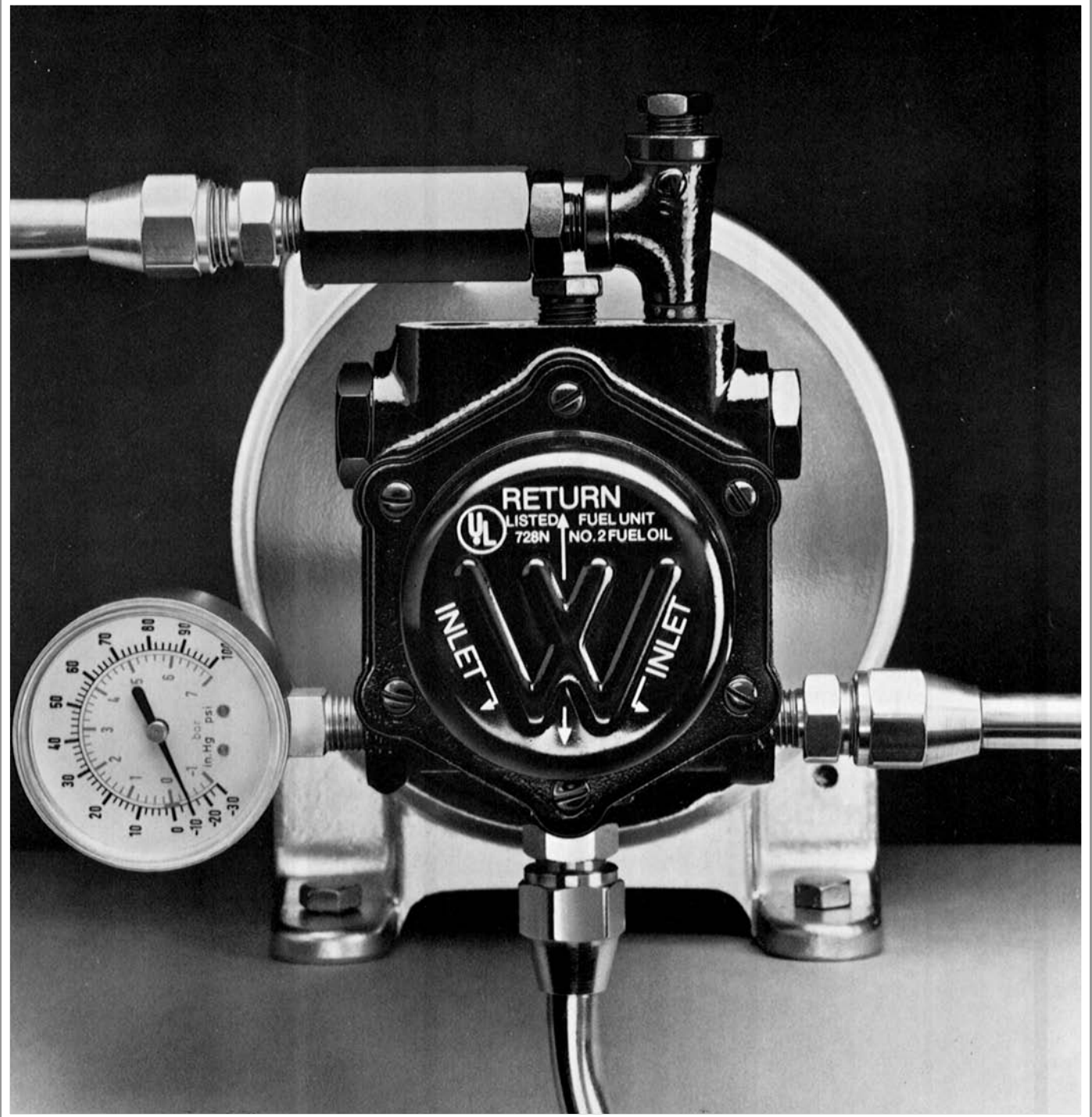

*A total service product from your unique, single-source supplier.*

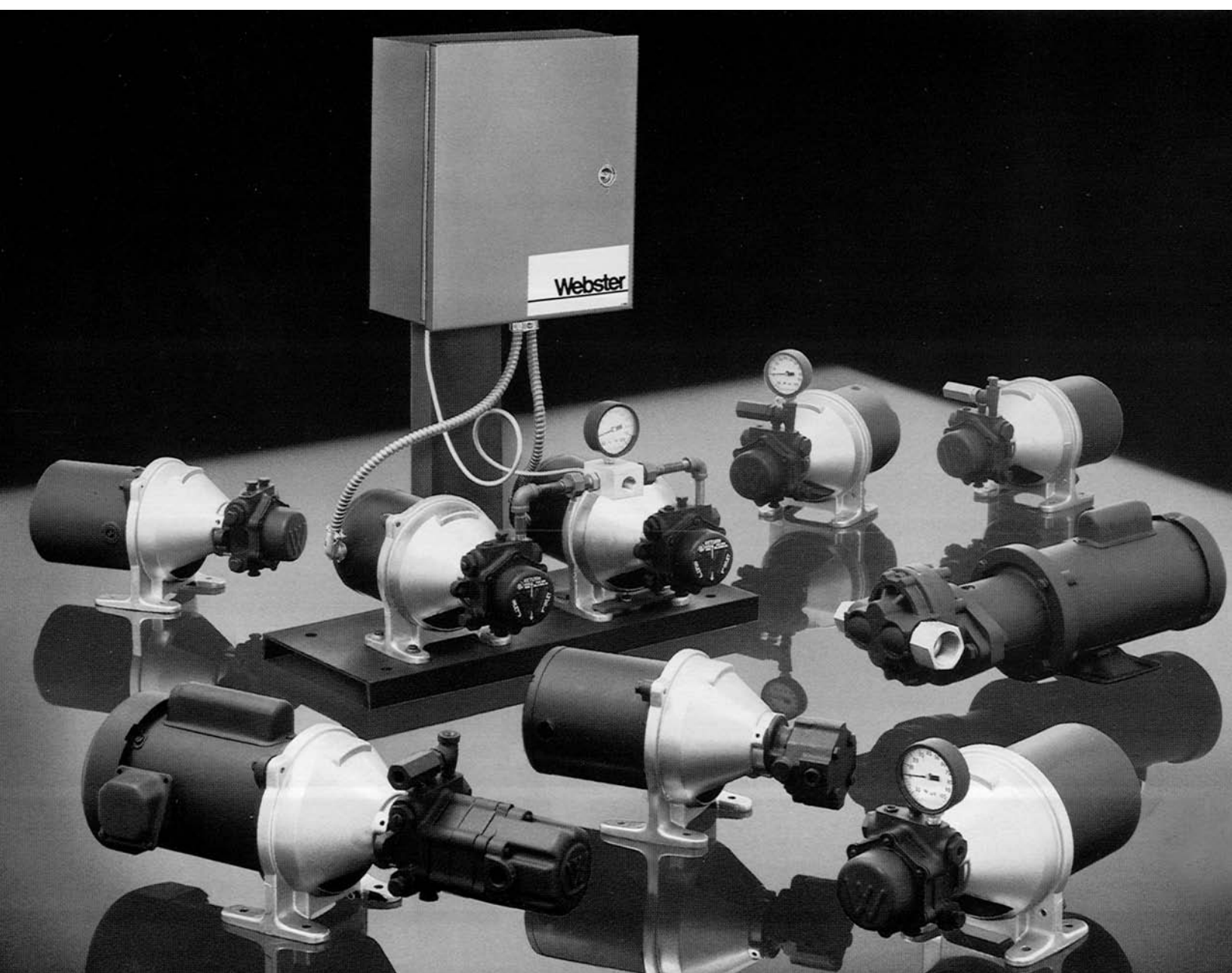

## The Most Complete Line of Transfer & Supply Pump Units In the Industry

Whether you're pumping one gallon of oil per hour - or several hundred - Webster has the transfer and supply pump/motor units to meet your demands.

This catalog details the three major categories of pump/motor units Webster manufactures: SPM supply pump units; SPMV high capacity pump units; transfer pump units (35223, 49116 and 35202 Series). All SPM Series units are also available as duplex manual or automatic models which provide a second pump for auxiliary service.

### Table of Contents

Selecting the Right Pump Unit .....	3
SPM Series Single Supply Units.....	4
SPM Series Duplex Supply Units .....	7
SPMV Series Single and Duplex Supply Units .....	10
SPMB Series Single and Duplex Supply Units.....	13
35223 Series Transfer Pump/Motor Units.....	15
49116 Series Transfer Pump/Motor Units.....	16
35202 Series Transfer Pump/Motor Units.....	17
Motor Bracket Assemblies.....	18

**Webster**<sup>®</sup>  
Fuel Pumps & Valves

## Selecting the Right Pump Unit

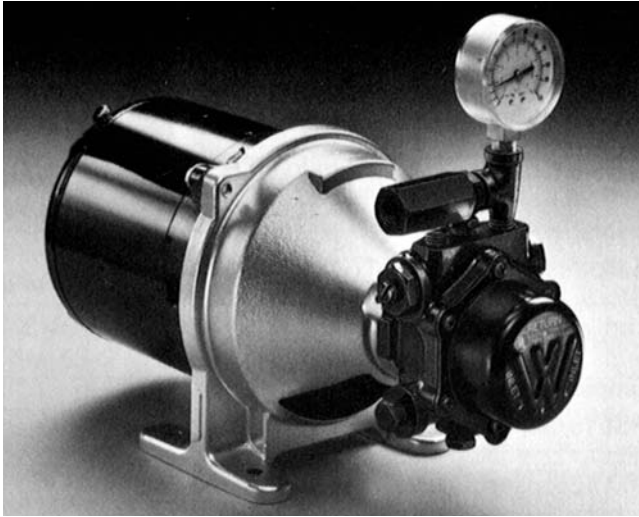

### SPM SERIES SUPPLY UNITS

Webster SPM supply pump units are the perfect choice for efficiently supplying oil to remote heating units or day tanks from a central storage tank. Four sizes are available with capacities of 15, 30, 65 and 135 GPH, combined with  $\frac{1}{6}$ ,  $\frac{1}{4}$ ,  $\frac{1}{3}$ , or  $\frac{1}{2}$  hp 1725 continuous-duty motors. The units are shipped completely assembled including check valve. Vacuum breaker and compound gauge are also included but not assembled to unit. See pages 4, 5 and 6 for additional information.

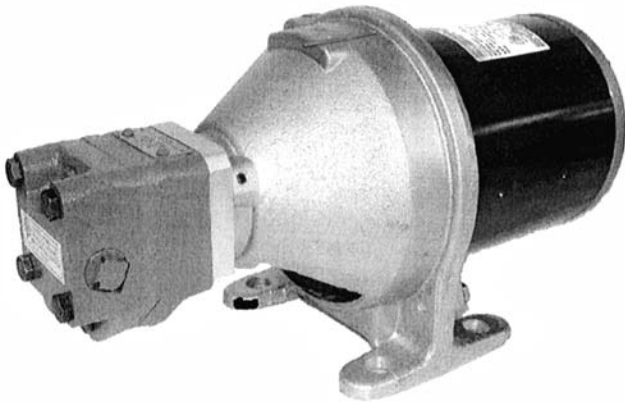

### 35223, 49116, 35202 Series Pump Units

Webster 35223, 49116 and 35202 Series pump units combine an electric motor and fuel unit or transfer pump to provide a broad range of pumping capabilities for transferring and supplying oil. 35223 and 49116 Series units are designed for transfer applications in flows ranging from 7 to 150 GPH. 35202 units can be used for fuel transfer for supply applications in flows not included in the SPM Series. See pages 15, 16, and 17 for additional information.

### SPMV SERIES SUPPLY UNITS

Designed for high capacity applications. Webster SPMV Series supply pump units deliver outputs from 430 to 1790 GPH. They feature proven gear type pumps in four sizes, with hardened shafts and gears and special anti-friction bearings for long dependable service. Pumps are flex-coupled to electric motors in sizes from  $\frac{1}{2}$  to 7.5 hp. See pages 10, 11 and 12 for additional information.

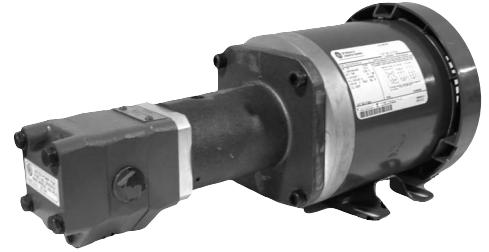

### SPMB Series

#### Single and Duplex Supply Units

B series transfer pumps are designed to provide efficient pumping of #1 to #6 fuel oils, in capacities from 80 to 290 gallons per hour, at pressures up to 500 PSI (except #1 oil). With high-density gray iron body construction, heat-treated alloy steel gears and shafts, and special antifriction bearings. B series transfer pumps offer superior durability and high mechanical efficiency. Double lip Viton seals, are standard. These pumps are also available in pump and motor packages. Available in 115/230 volt single phase or 230/460 volt three phase, simplex, duplex automatic and duplex manual configurations. All B series pumps are UL approved.

### DUPLEX SUPPLY UNITS

SPM, SPMB and SPMV Series supply pump units are available as either duplex automatic or manual models. Duplex supply units have two supply pump units; one that operates continuously if required, and the other offering backup service for applications where a constant supply of oil is essential. Duplex automatic units provide unmanned auxiliary pump activation, while manual units require an operator to activate the backup pump. See pages 7, 8, 9, 10, 11, 12, 13, and 14 for further information.

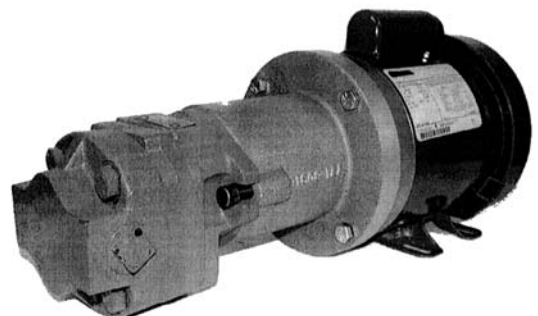
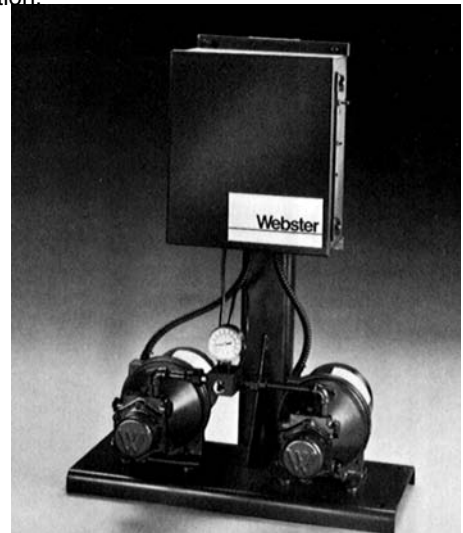

## SPM Series Single Supply Units

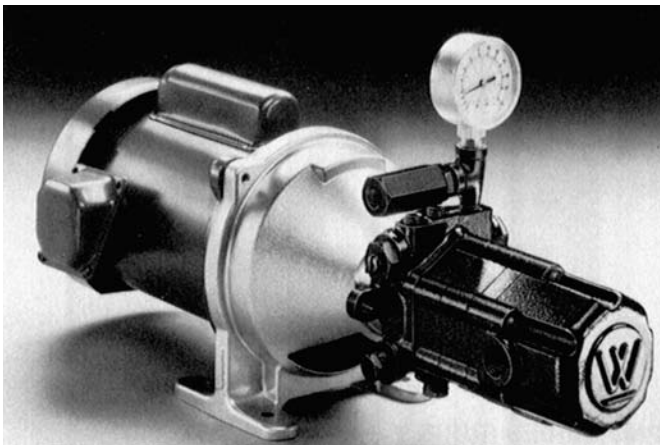
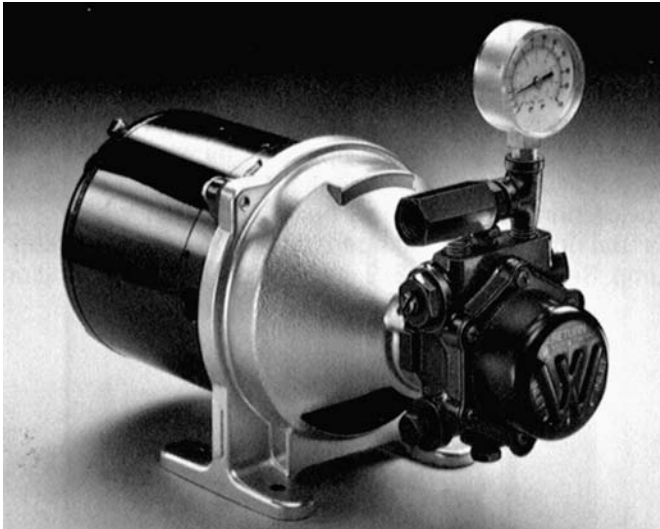

### FEATURES

SPM Series pump/motor units consist of a fuel pump direct coupled to a motor, an integral check valve and combination vacuum/pressure gauge. They are designed to supply fuel oil from a central storage tank to one or more overhead furnaces or day tanks. Four pump/motor sizes are available, with capacities of 15, 30, 65 and 135 GPH. 1/6, 1/4 and 1/3 hp (124 w, 186 w and 248 w) motors are split phase available for either 115 or 230 volt operation. 1/2 hp (373 w) motors are capacitor start – induction run, totally enclosed with dual 115/230 volt windings. The units are shipped completely assembled including check valve. Compound gauge is also included but not assembled to unit. All are 60 cycle, 1725 RPM, continuous duty.

SPM-15, SPM-30 and SPM-65 (pictured upper left) utilize modified, two stage Webster R Series fuel units. Model SPM-135 (pictured lower left) utilizes modified two stage V Series Pumps.

### SPECIFICATIONS

#### Capacities:

15, 30, 65, and 135 GPH.

#### Pressure:

Maximum operating pressure to 80 PSI or 200' of head.

#### Motors:

All motors are 60 cycle, 1725 RPM, continuous duty.  
1/6, 1/4, 1/3 hp: split phase, 115 or 230 volt operation.  
1/2 hp: capacitor start/induction run, TEFC, dual 115/230

#### Pumps:

SPM 15, 35, and 65: uses Webster "2R" Series pump units.  
SPM 135: uses the Webster "2V" Series pump unit.  
Webster 2R and 2V are UL listed.

#### Porting:

SPM15, 30, 65:  
1/4" NPTF — 2 inlets, outlet port and top and bottom returns.

#### SPM135:

1/4" NPTF — outlet port  
3/8" NPTF — return port, 2 optional inlets.  
1/2" NPTF — inlet.

#### Seal:

All models — double lip type.

#### Mounting:

All models — four bolt foot mount.

#### Filter:

Rotary self cleaning type, except in SPM 135. Use of external line filter recommended.

#### Valves:

Pressure regulating assembly in pump maintains set pressure.  
Check valve maintains oil in feeder lines for instant starts.

#### Gauge:

2 1/2" dia., calibrated from 30" vacuum to 100 PSI.

#### Maximum Inlet Vacuum:

All units — 15" Hg.

National Fire Protection Association compliance requires fuel inlet pressure not to exceed 3 PSIG.

**SELECTION TABLE — SPM Series Single Units**

Models	Motor Voltage	Motor Type No.	Motor HP	Watts at 85 PSI	Pump Assembly No. <sup>1</sup>	Pump Model No.	Suction Capacity GPH	Max. Output Flow @ 0 PSI GPH	Total Firing Rate GPH <sup>2</sup>	BTU (millions)
SPM-15-1 SPM-15-2	115 230	34499-1 34499-2	1/6	65	35196-5	2R181C-5BQ4	35	25	15	1.5
SPM-30-1 SPM-30-2	115 230	34499-3 34499-4	1/4	95	35196-6	2R283C-5BQ4	70	45	30	3.0
SPM-65-1 SPM-65-2	115 230	34499-8 34499-9	1/3	175	35196-7	2R686C-5BQ4	125	90	65	6.5
SPM-135	Dual 115/230	34499-6	1/2	300	35196-8	2V086C-5DO4	250	167	135	13.5

<sup>1</sup> SPM Series units are available less motor; order by Pump Assembly Part Number. Motor and Bracket Assemblies (less pump) are also available. (See page 14)

<sup>2</sup> Firing rate in GPH @ 1725 RPM pumping #2 fuel oil @ 75° F. Total firing rate is equal to the sum of burner firing rates when burners are set for one-pipe operation as recommended. Total must not exceed maximum rating shown.

**DIMENSIONS  
SPM Single Units**

Models	A	B	C	D
SPM-15	6.88	16.36		
SPM-30	7.44	17.42		
SPM-65	8.96	18.94		
SPM-135			10.94	21.51

The basic dimensions indicated apply to all size SPM units. Refer to the table for variable dimensions "A" through "D."

Model SPM-135 (with 1/2 HP motor) includes external motor starter capacitor and junction box illustrated by dotted lines. Larger cover with preferred inlet on Model SPM-135 also illustrated by dotted lines.

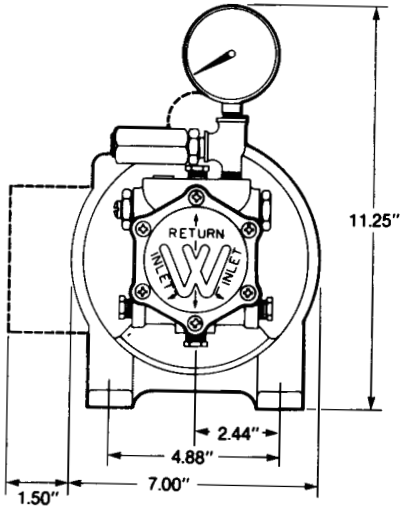
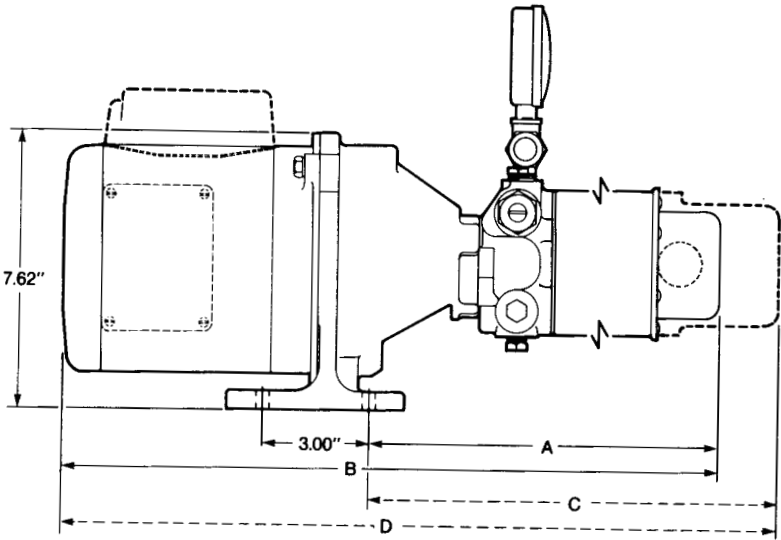

## Section Two: SPM Single Supply Units

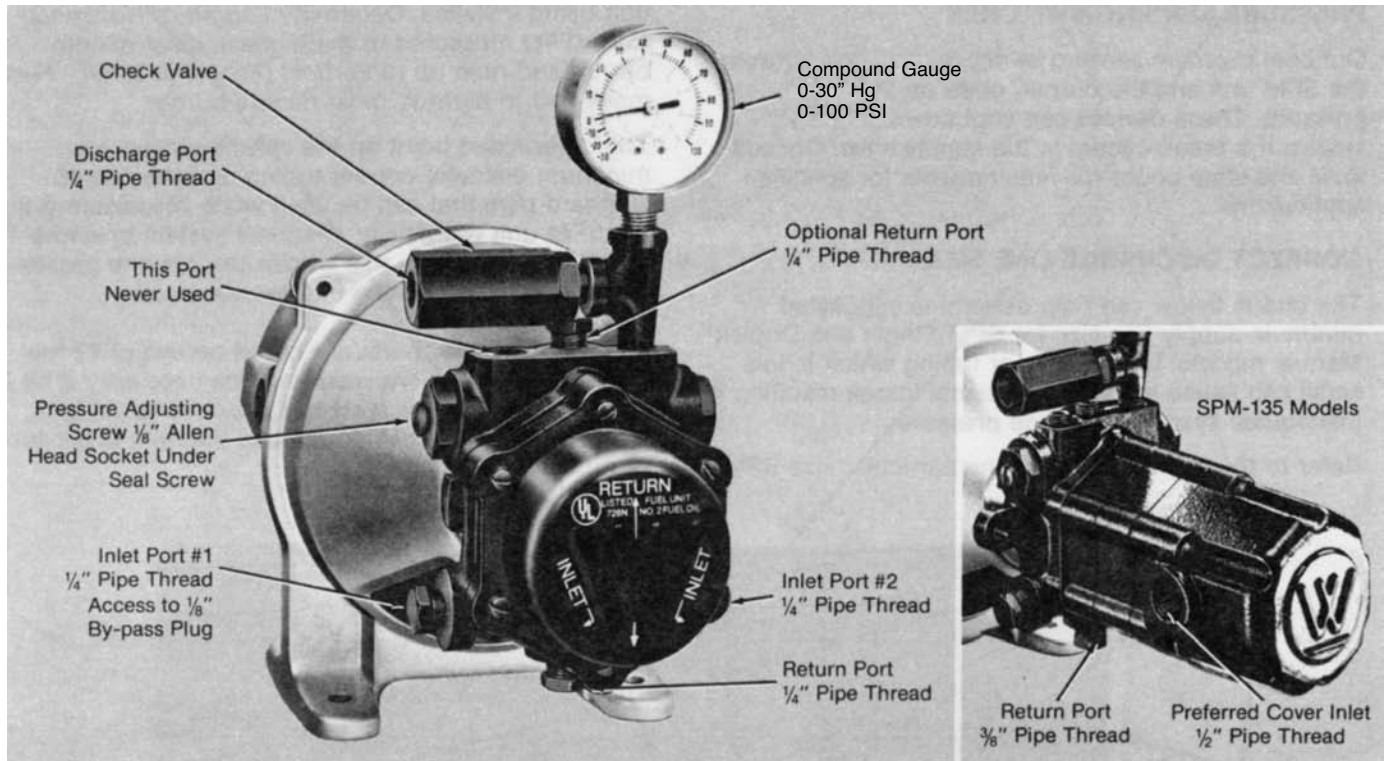

### SPECIFICATIONS

SPM Single and Duplex Manual units are capable of supplying fuel oil to heating units or tanks located up to 200 feet above the supply pumps. They are designed for use in maintained pressure or open loop systems. Pump pressures can be set at a range from 20 PSI to 100 PSI. See *Correct Supply Line Size* charts for maximum discharge head.

### TANK TO PUMP CONNECTIONS

Connect suction line from the tank to preferred supply pump inlet port. Connect return line from pump return port to tank. Internal 1/8" by-pass plug (factory installed) must be in position for recommended two pipe operation. **Be certain all plugs and connections are secure and leak tight.**

The correct suction line size can be determined by referring to the line sizing charts. Generally, the return line should be sized the same as the suction line. Check valves in the suction lines between the tank and SPM units assure that pumps are full of oil, ready for

service. Check valves must be oil tight. Low pressure drop swing type are recommended to minimize friction loss.

For SPM Duplex Manual models, preferred installation calls for a separate suction line from tank to pump for each pump/motor unit. If system failure occurs because of a gross leak in the suction line of the primary unit, the second unit can still provide backup service. Check valves can be installed in return lines to allow removal of inactive pump for servicing, while primary pump continues to run.

# SPM Series Duplex Supply Units

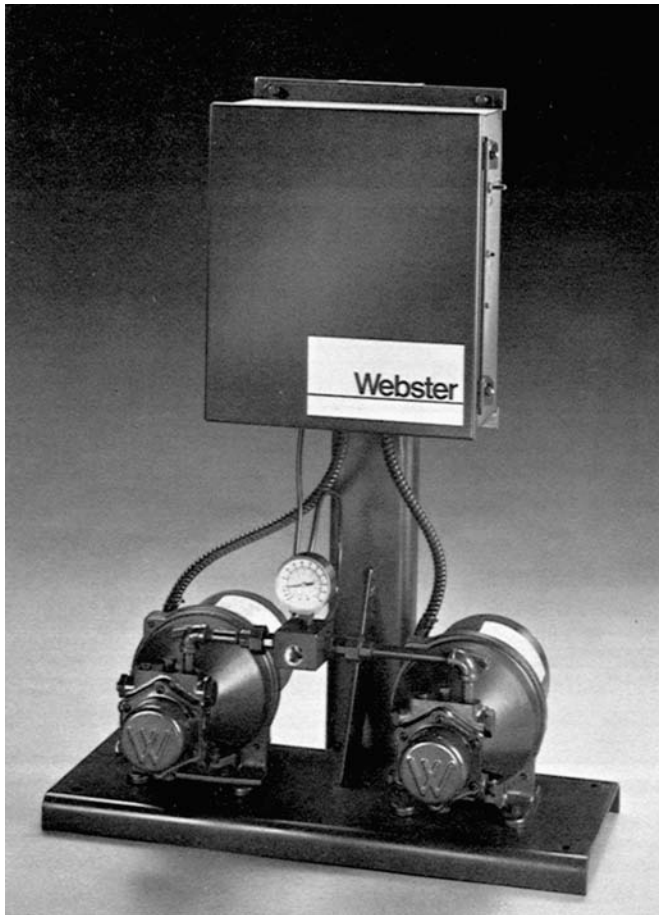

## FEATURES

The SPM duplex models consist of two pump/motor assemblies with a pre-piped, common discharge manifold. One pump/motor unit operates continuously, with the second providing backup service if the main pump fails. Either automatic (SPM-DA models) or manual (SPM-DM models) controls are available.

The duplex automatic series are designed specifically for buildings where a constant supply of oil must be assured . . . hospitals, apartment buildings, schools and other commercial/industrial buildings.

The DA Series is equipped with a pressure sensing device which detects a loss in pressure of the primary pump. If the standby pump is brought into service, an alarm sounds which indicates a malfunction in the primary pump.

The electric control circuit on the duplex automatic pump set is equipped with a lead-lag switch to permit manual alternation of pump to provide even wear on each pump.

The manually operated duplex pump sets offer the same protection as an automatic except the standby pump must be turned on manually which requires that maintenance personnel always be available.

## SPECIFICATIONS

**Same as SPM Single except:**

**Controls:** Two Types for Duplex Units Only  
Duplex automatic with lead-lag switch and alarm.  
Manual with selector switch.

**SELECTION TABLE — SPM Series Duplex Units**

Models	Motor Voltage	Controls	Motor HP	Watts at 85 PSI	Pump Model Number	Suction Capacity GPH	Max. Output Flow @ PSI, GPH <sup>1</sup>	Total Firing Rate GPH <sup>1</sup>	BTU (millions)
SPM-15-1-DA	115	Automatic	1/6	65	2R181C-5BQ4 (35196-5)	35	25	15	1.5
SPM-15-1-DM	115	Manual							
SPM-15-2-DA	230	Automatic	1/4	95	2R283C-5BQ4 (35196-6)	70	45	30	3.0
SPM-15-2-DM	230	Manual							
SPM-30-1-DA	115	Automatic	1/3	175	2R686C-5BQ4 (35196-7)	125	90	65	6.5
SPM-30-1-DM	115	Manual							
SPM-30-2-DA	230	Automatic	1/2	300	2V086C-5DO4 (35196-8)	250	167	135	13.5
SPM-30-2-DM	230	Manual							
SPM-65-1-DA	115	Automatic	1/2	300	2V086C-5DO4 (35196-8)	250	167	135	13.5
SPM-65-1-DM	115	Manual							
SPM-65-2-DA	230	Automatic	1/2	300	2V086C-5DO4 (35196-8)	250	167	135	13.5
SPM-65-2-DM	230	Manual							
SPM-135-DA	Dual	Automatic	1/2	300	2V086C-5DO4 (35196-8)	250	167	135	13.5
SPM-135-DM	115/230	Manual							

<sup>1</sup> Firing rate in GPH @ 1725 RPM pumping #2 fuel oil @ 75° F. Total firing rate is equal to the sum of burner firing rates, when burners are set for one-pipe operation as recommended. Total must not exceed maximum rating shown.

## SPM Duplex Automatic Models

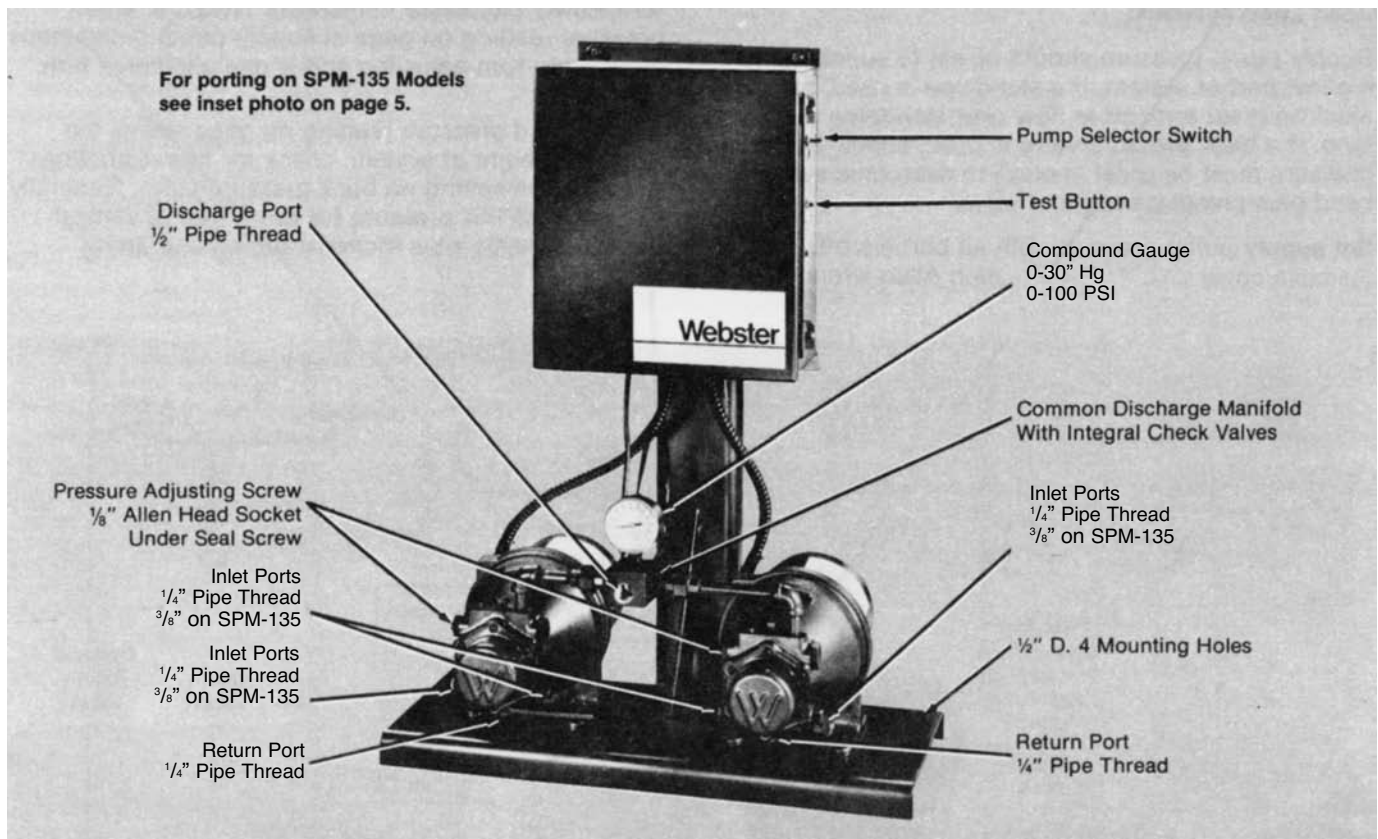

### SPECIFICATIONS

SPM Duplex Automatic units consist of two SPM Series Pump/Motor assemblies and an electrical control panel. They are designed for use in maintained pressure supply systems *only*. If system pressure falls below a preset level, the control automatically switches from the primary pump/motor unit to the secondary unit. If the backup pump/motor unit also fails to reach or maintain preset system pressure, the control also shuts off the backup unit.

A pump selector switch allows the two pump/motor units to be manually alternated for even wear on each pump. Pump pressures can be set at a range from 20 PSI to 100 PSI. See Correct Supply Line Size charts for maximum discharge head.

### TANK TO PUMP CONNECTIONS

Units should be set for two pipe operation. Preferred installation calls for a separate suction line from tank to pump for each pump/motor unit. If system failure

occurs because of a gross leak in the suction line of the primary unit, the second unit can still provide backup service.

The correct suction line size can be determined by referring to the line sizing charts. Generally, the return line should be sized the same as the suction line. Low pressure drop, swing type check valves can be installed in the suction lines, assuring that pumps are full of oil, ready for service. Check valves in return lines allow removal of inactive pump for servicing. Use of shutoff valves in return lines is not recommended.

**Be certain all plugs and connections are secure and leak-tight.**



## DIMENSIONS

The basic dimensions indicated apply to all SPM Duplex models. Refer to table for variable dimension "A" and pipe tap size.

### SPM DUPLEX MANUAL SUPPLY UNIT

Models	A	Pipe Tap
SPM-15	14.94	1/4
SPM-30	16.53	1/4
SPM-65	16.90	1/4
SPM-135	21.37	3/8

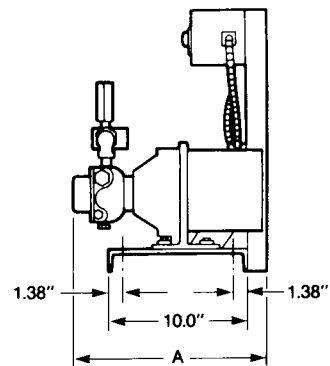
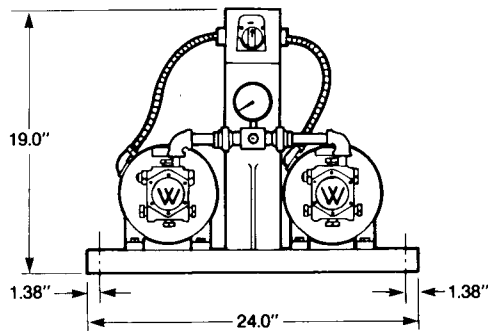

### SPM DUPLEX AUTOMATIC SUPPLY UNIT

Models	A	Pipe Tap
SPM-15DA	14.94	1/4
SPM-30DA	16.53	1/4
SPM-65DA	16.90	1/4
SPM-135DA	21.37	3/8

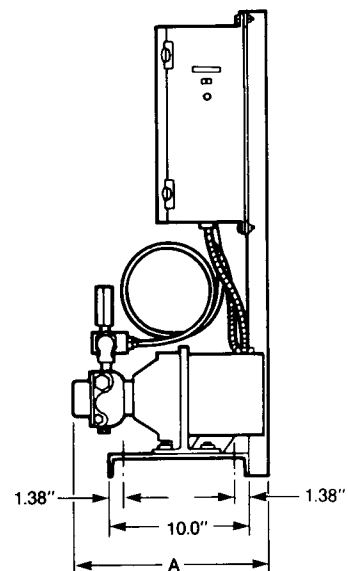
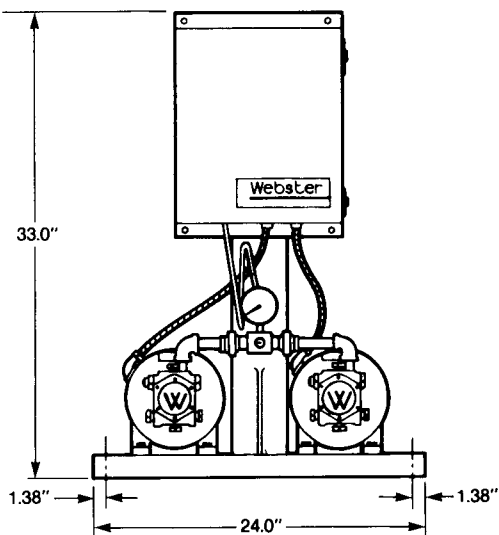

## SPMV Series Single and Duplex Supply Units

---

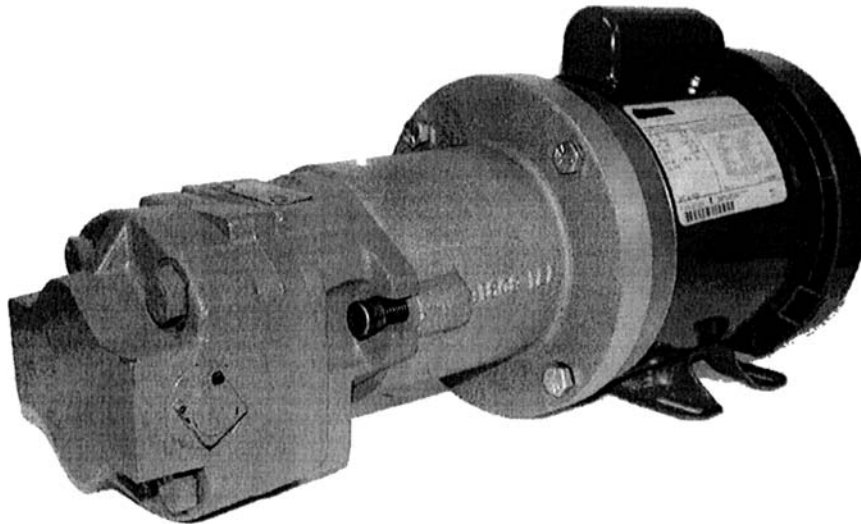

Webster SPMV single and duplex supply units are designed for high capacity applications where 430 to 1790 GPH are required. Quite running, gear type pumps are available in four sizes and incorporated hardened integral shafts, journals and gears, special anti-friction bearings. Buna-N seals, and cast iron gear plates. Standard motors ranging from 1/2 hp to 7.5 hp (373 w to 11.2 kw) are 1725 RPM NEMA "C" face, 115 volt single-phase or 230 volt three-phase, 60 cycle type with TEFC enclosures through 2 hp (1490w) and OPDP enclosures over 2 hp (1490w).

Webster SPMV motor/pump high capacity fuel oil supply units are designed to be used with fuels oils including JP4. Fluid viscosities should not exceed 6000 SUS. Suction should exceed 10" Hg. Inlet pressures are rated at 34 PSI continuously and 50 PSI for short periods. The unit is designed to operate in -29° F to +200° F conditions, depending on viscosity of oil. The motor is precision aligned and coupled to pump with machined adapter and flexible coupling.

### SPECIFICATIONS

Capacity:  
430 to 1790 GPH with fluid viscosity to 10,000 SSU.

### Pressure:

Inlet pressure not to exceed 35 PSI. Outlet pressure up to 500 PSI.

### Fluid Temperature Limits:

29° F to +200° F

### Motors:

Standard: 60 cycle, 1725 RPM, NEMA "C" face. 1/2 through 15 hp available.  
To be specified when ordering: Single-phase 115/208/230 VAC, or three-phase 208/230/460 VAC. ODP or TEFC

### Porting:

1 NPT port. 086K-194K  
1 1/4 NPT 1 1/2 port. 237K-388K

### Mounting:

Integral mounting foot.

### Maximum Inlet Pressure:

Continuous operation: 10" Hg or pressure not exceed 35 PSI.  
Intermittent operation: 20" Hg and 50 PSI.  
Use of external filter recommended.

# SPMV Ordering Code

<b>SPMV</b>	<b>50</b>	<b>A</b>	<b>T</b>	<b>086K</b>	<b>DM</b>

## MOTOR HORSEPOWER (1725 RPM STANDARD)

1	No.	Description
	50	.50 HP
	75	.75 HP
	100	1.0 HP
	150	1.5 HP
	200	2.0 HP
	300	3.0 HP
	500	5.0 HP
	750	7.5 HP

\* = only available in 115V or 230V single phase

## MOTOR HORSEPOWER (1725 RPM STANDARD)

		<i>Under pressure, read horsepower required at 1750 RPM</i>				
4	Pump Model	Maximum gph Nominal	25 psi	100 psi	200 psi	300 psil
	086K	439	.50	.75	1.00	1.50
	194K	902	1.00	1.75	2.50	3.00
	237K	1114	1.00	2.00	3.00	4.00
	388K	1791	2.00	3.50	4.50	6.00

## MOTOR PHASE

2	Code	Description
	A	Single Phase / 60 cycle / 115/208/230 VAC
	B	Three Phase / 60 cycle / 208 / 230 / 460 VAC
	X	Consult factory for other types

## MOTOR ENCLOSURE

3	Code	Description
	T	TEFC Std. thru 2 HP
	O	OPDP Std. over 2 HP

## SPMB Duplex Ordering Code

When ordering SPMV Duplex models add suffix:

“DM,” for manual control models, or “DA,” for automatic control models.

Example: SPMV-50AT/086K-DA

5	Code	Duplex Units
	DM	Duplex with manual controls
	DA	Duplex with automatic controls

When sizing SPMV units, remember that the pressures indicated are at the pump outlet.

All pumps relying on atmospheric pressure to push the fuel oil into them are subject to cavitation. As fuel viscosity (thickness) increases, the tendency for cavitation becomes greater. Therefore, it is best to mount the pump at the base of the tank and to use the largest diameter, shortest length, and straightest inlet possible.

A large diameter inlet pipe or hose necked-down at the pump is preferable to a longer length of similar diameter pipe because the fuel tends to adhere to the inside of the pipe.

When initially starting a unit, it is desirable and sometimes necessary to have a vent valve or plug on the pressure side of the pump to facilitate its priming.

# SPMV Series Single and Duplex Supply Units

## DIMENSIONS

HP	Motor		A	B	C	D
	NEMA	Type				
	Fame Size	Type (Standard)				
.50	56C	TEFC	6.30	9.00	8.25	9.20
.75	56C	TEFC	6.30	9.00	8.25	9.20
1.00	56C	TEFC	6.30	9.00	8.25	10.20
1.50	56C	TEFC	6.30	9.00	8.25	11.20
2.00	56C	TEFC	6.30	9.00	8.25	11.20
3.00	182TC	OPDP	7.30	9.63	11.05	11.00
5.00	184TC	OPDP	7.30	9.63	11.05	12.40
7.50	213TC	OPDP	8.00	11.63	13.00	13.90

Pump Model	E	F	
		Minimum	Maximum
086K	4.90	19.05 (.50HP)	20.85 (3.00HP)
194K	5.65	19.90 (.75HP)	23.10 (5.00HP)
237K	8.80	23.15 (.75HP)	27.85 (7.50HP)
388K	9.80	23.95 (.75HP)	28.65 (7.50HP)

### SPMV SINGLE SUPPLY UNIT

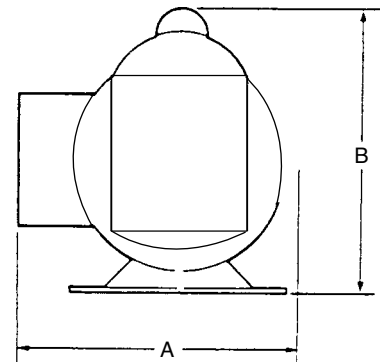
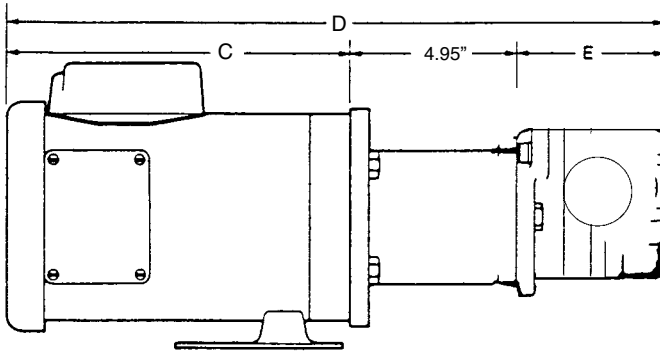

### SPMV DUPLEX SUPPLY UNIT

(Dimensions are for 3 Phase Duplex Automatic Consult Factory for Single Phase Dimensions)

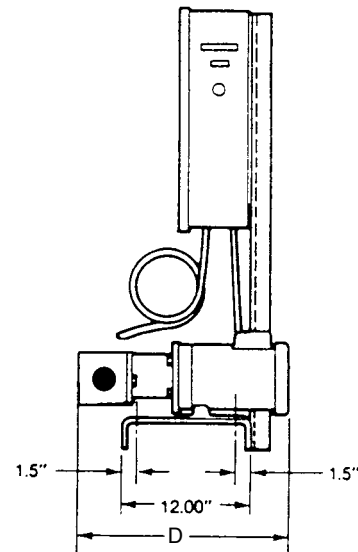
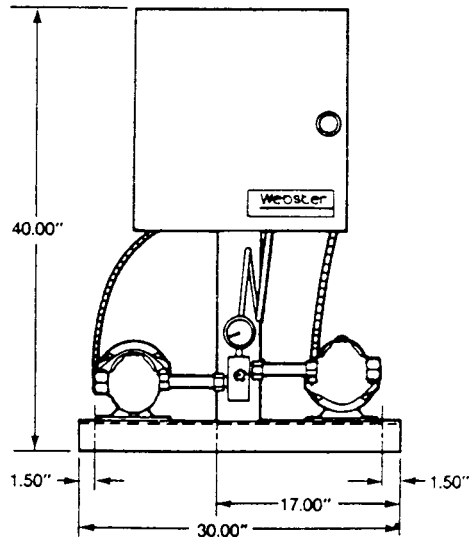

## SPMB Series Single and Duplex Supply Units

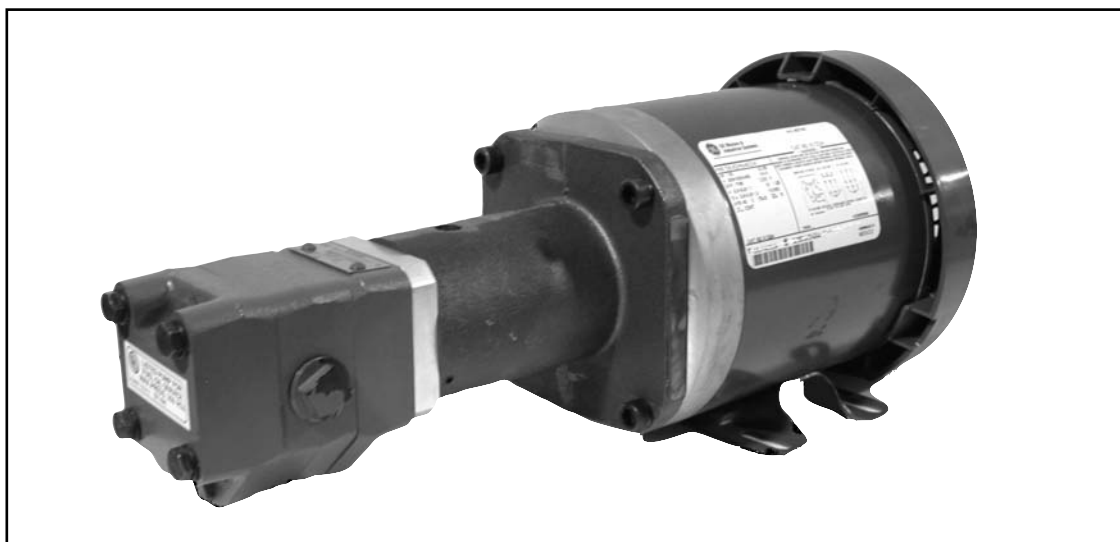

### Specifications

<b>Gear Sizes:</b>	18B1 (.35" gear width) 37B1 (.70" gear width) 47B1 (1.00" gear width) 59B1 (1.40" gear width)
<b>Capacity:</b>	80 to 290 GPH @ 1750 RPM #1 to #6 fuel oil @ 75 degrees F., 100 PSI)
<b>Pressures:</b>	#4 to #6 fuel oils - up to 500 PSI #2 fuel oil - up to 350 PSI
<b>Operating Speeds:</b>	To 1725 RPM
<b>Porting: *</b>	1/2" NPTF: Side inlet and side outlet 3/4" NPTF: Side inlet and side outlet 59B only
<b>Shaft Seal:</b>	Standard - Double lip type, Viton
<b>Filter:</b>	No internal filter External filter recommended
<b>Relief Valve:</b>	No Relief Valve Use External Relief Valve
<b>Inlet Vacuum:</b>	10" Hg maximum

### UL Listed

### SPMB PUMP/MOTOR UNITS

Available in flow rates from 80 GPH through 290 GPH. Systems can be designed for single phase 115/208/230V, 60 or 50CY, or three phase 208/230/460V, 60 or 50CY, applications. The SPM duplex models consist of two pump and motor assemblies with a pre-piped common discharge manifold. One pump operates continuously, with the second providing backup service if the main pump fails. Either automatic (SPM-DA models) or manual (SPM-DM models) controls are available. The duplex automatic series are designed specifically for buildings where a constant supply of oil must be assured...hopsital, apartment buildings, schools and other commerical or industrial buildings. The duplex pump set has a second pump for standby or auxiliary service. Furnished with automatic or manual standby controls, the duplex automatic is equipped with a pressure sensing device which detects loss of pressure of primary pump. If standby pump is brought into service, and alarm sounds which indicates malfunction in primary pump. The electric control circuit on the duplex automatic pump set is equipped with a lead-lag switch to permit manual alternation of pump to provide even pump wear. The manually operated duplex pump sets offer the same protection as the automatic except the standby pump must be turned on manually which requires that maintenance personnel always be available. Available with either SPM or SPMV pump/motor units.

When sizing SPMB units, remember that the pressures indicated are at the pump outlet.

All pumps relying on atmospheric pressure to push the fuel oil into them are subject to cavitation. As fuel viscosity (thickness) increases, the tendency for cavitation becomes greater. Therefore, it is best to mount the pump at the base of the tank and to use the largest diameter, shortest length, and straightest inlet possible.

A large diameter inlet pipe or hose necked-down at the pump is preferable to a longer length of similar diameter pipe because the fuel tends to adhere to the inside of the pipe.

When initially starting a unit, it is desirable and sometimes necessary to have a vent valve or plug on the pressure side of the pump to facilitate its priming.

# SPMB Series Single and Duplex Supply Units

## DIMENSIONS

HP	Motor		A	B	C
	NEMA Fame Size	Type (Standard)			
.50	56C	TEFC	9.00	8.25	9.20
.75	56C	TEFC	9.00	8.25	9.20
1.00	56C	TEFC	9.00	8.25	10.20
1.50	56C	TEFC	9.00	8.25	11.20
2.00	56C	TEFC	9.00	8.25	11.20
3.00	182TC	OPDP	9.63	11.05	11.00
5.00	184TC	OPDP	9.63	11.05	12.40
7.50	213TC	OPDP	11.63	13.00	13.90

Pump Model	E	D
18BR	3.36	(.50HP) 17.06
37BR	3.71	(.75HP) 17.41
47BR	4.05	(.75HP) 17.75
59BR	4.40	(.75HP) 18.10

## SPMB Ordering Code

<b>SPMB</b>	<b>50</b>	<b>A</b>	<b>T</b>	<b>18BR</b>	<b>DM</b>
<b>1</b>	<b>2</b>	<b>3</b>	<b>4</b>	<b>5</b>	

### MOTOR HORSEPOWER (1725 RPM STANDARD)

<b>1</b>	No.	Description
*	25	.25 HP
*	33	.33 HP
	50	.50 HP
	75	.75 HP
	100	1.0 HP
	150	1.5 HP
	200	2.0 HP
	300	3.0 HP

\* = only available in 115V or 230V single phase

### MOTOR PHASE

<b>2</b>	Code	Description
	A	Single Phase / 60 cycle / 115/208/230 VAC
	B	Three Phase / 60 cycle / 208 / 230 / 460 VAC
	X	Consult factory for other types

### MOTOR ENCLOSURE

<b>3</b>	Code	Description
	T	TEFC Std/ thru 2 HP
	O	OPDP Std. over 2 HP

### SPMB SINGLE SUPPLY UNIT

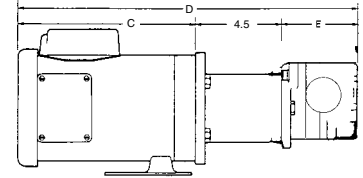
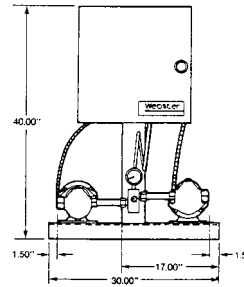

### SPMB DUPLEX SUPPLY UNIT

(Dimensions are for 3 Phase Duplex Automatic Consult Factory for Single Phase Dimensions)

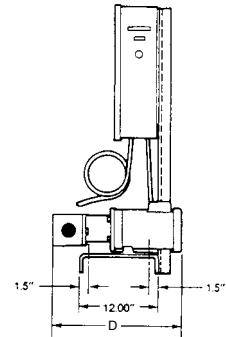
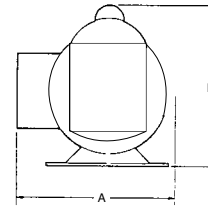

### MOTOR HORSEPOWER (1725 RPM STANDARD)

<b>4</b>	Pump Model	Maximum gph Nominal	Under pressure, read horsepower required at 1750 RPM			
			25 psi	100 psi	200 psi	300 psil
	18BR	82	.25	.25	.25	.33
	37BR	159	.25	.25	.50	.75
	47BR	220	.25	.50	.75	1.00
	59BR	292	.25	.50	.75	1.50

### SPMB Duplex Ordering Code

When ordering SPMB Duplex models add suffix:

“DM,” for manual control models, or “DA,” for automatic control models.

Example: SPMB-50AT/18BR-DA

<b>5</b>	Code	Duplex Units
	DM	Duplex with manual controls
	DA	Duplex with automatic controls

# 35223 Series Transfer Pump/Motor Units

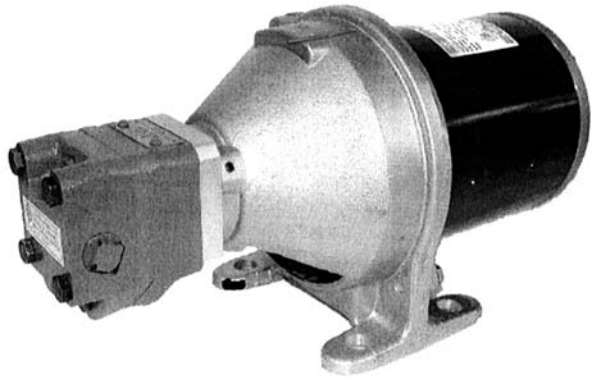

**Maximum Inlet Vacuum:**

10" Hg.

**Valves:**

An external regulating valve should be mounted in the discharge line if pressure regulation is necessary.

**Motor:**

1/4 hp, 60 cycle, 1725 RPM, continuous duty 115 volt, split phase.

**Pump:**

"B" Series Transfer Pump.

**Working Pressure:**

Maximum - 200 PSI  
100 PSI for 35223-3

**Mounting:**

Four bolt foot mount - see dimensional drawings.  
Use of external filter recommended.

**FEATURES**

The 35223 Series Pump/Motor Unit consists of a Webster B Series fuel oil transfer pump close coupled to a 1/4 hp electric motor. This unit is designed for transfer of fuel oils #6 or lighter at maximum working pressures up to 200 PSI depending on motor hp.

**SPECIFICATIONS**

**Capacity:**

80 to 155 GPH at 100 PSI.

**SELECTION TABLE - 35223 Series Pump/Motor Units**

Models	Models Voltage	Motor HP	Pump Model	Maximum Working Pressure	Maximum Outlet/Flow @ 100PSI
35223-1	115	1/4	18B	200 PSI	80 GPH
35223-3	115	1/4	37B	100 PSI	155 GPH

<sup>1</sup>NOTE: At 1725 RPM using #2 fuel at 75° F.

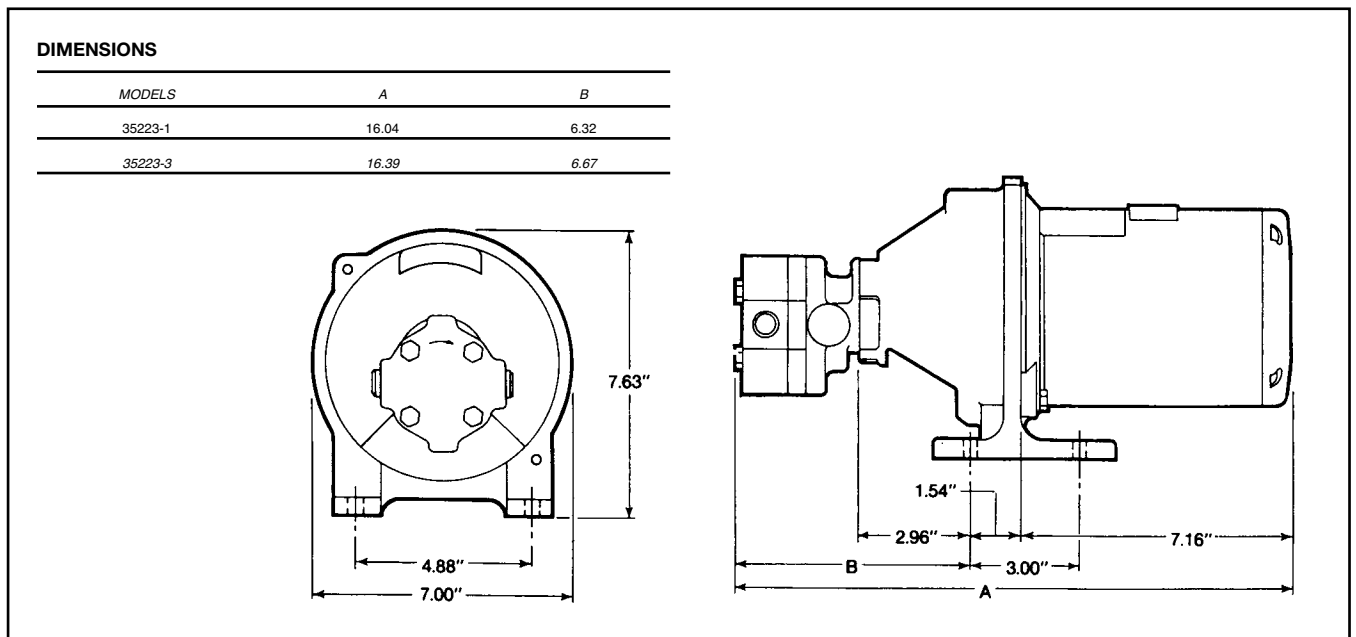

# 49116 Series Transfer Pump/Motor Units

## FEATURES

49116 Series Pump and Motor units consist of a Webster 1R00 Series pump close coupled to an electric motor. The pumps have no internal pressure regulating valve or filter. Single pipe installation is recommended with the internal bypass plug in position. The pump should not be operated with blocked outlets.

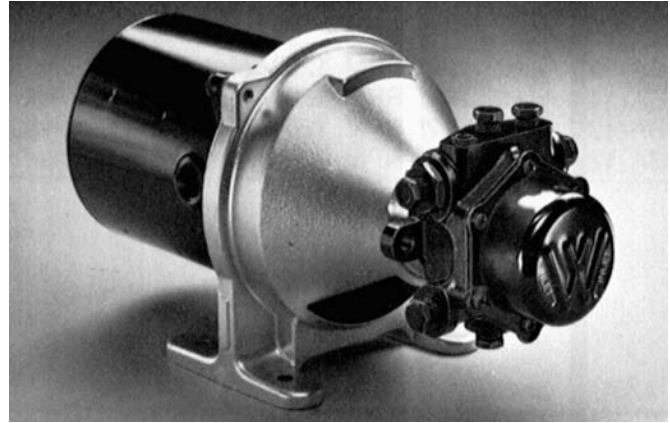

## SPECIFICATIONS

### Capacity:

31 to 66 GPH @ 100 PSI - see selection table.

### Maximum Inlet Vacuum:

10 Hg.

### Working Pressure:

Maximum - 100 PSI.

### Motors:

¼ hp, 115 Volt, 60 cycle, 1725 RPM, continuous duty.

### Mounting:

Four bolt foot mount - see dimensional drawings.  
Use of external filter recommended.

## SELECTION TABLE

Models	Replaces Discontinued Model	Pump Type No.	Suction Capacity GPH <sup>1</sup>	Delivery GPH @ 100 PSI <sup>1</sup>
49116	35223-19 35223-21	1R003C-4EH	48	31
49116-1	35223-23 35223-25	1R004C-4EH	66	43
49116-2	—	1R006C-4EH	95	66

<sup>1</sup> Capacity in GPH @ 1725 RPM pumping #2 fuel oil @ 75°F.

## DIMENSIONS

Models	A	B
49116	14.79	6.08
49116-1	15.41	6.71
49116-2	15.41	6.71

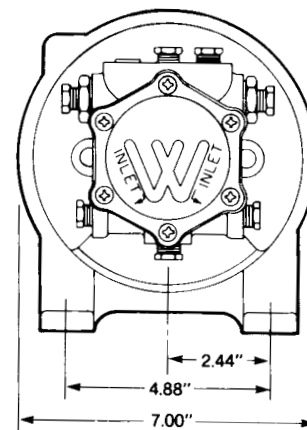
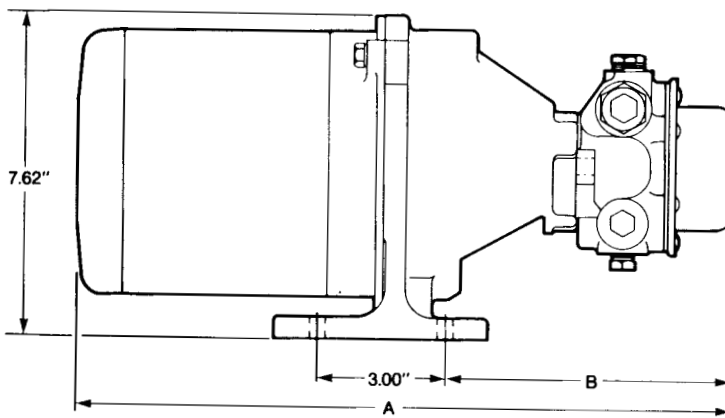



# 35202 Series Transfer Pump/Motor Units

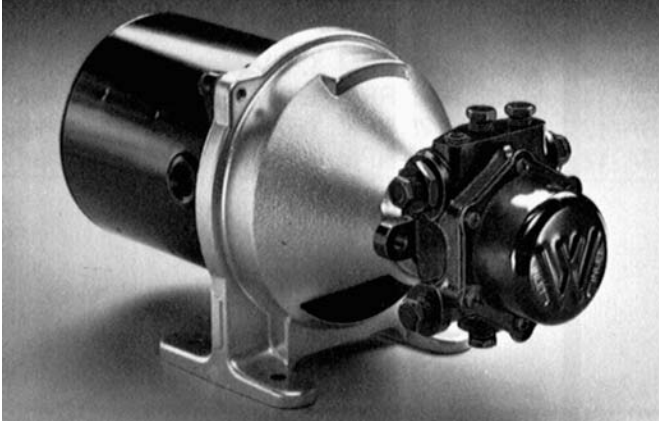

## FEATURES

35202 Series units consist of a Webster R Series or V Series fuel unit with integral pressure valve, close coupled to a motor. Two models are available less motor, or can include other accessories.

## SPECIFICATIONS

### Capacity:

7 to 60 GPH @ 300 PSI maximum working pressure. 9 to 65 GPH @ 100 PSI - see selection table.

### Maximum Inlet Vacuum:

10" Hg or 15" Hg (depending upon model).

### Working Pressure:

100 to 300 PSI, see selection table.

### Motors:

60 cycle, 1725 RPM, continuous duty. 1/6 hp and 1/4 hp motors are split phase. 1/2 hp motors are capacitor start-induction run, totally enclosed with dual 115/230 volt windings.

### Mounting:

Four bolt foot mount - see dimension drawing. Use of external filter recommended.

## SELECTION TABLE

Models	Motor Voltage	Type No.	Motor HP	Fuel Unit Type No.	Maximum Working Pressure PSI	Pump Blocked Nozzle Watts	GPH @ 100 PSI	GPH @ Maximum Working Pressure
35202	115	34499-3	1/4	2R223C-5BQ14	300	210	30	23
35202-2	115	34499-1	1/6	2R111C-5BQ3	150	75	12	10
35202-9	Less motor, includes accessories			2R213C-5BQ14	150	130	30	29
35202-10	Less motor, includes accessories			2R616C-5BQ14	150	245	65	60
35202-27	115	34499-1	1/6	1R162C-4BQ6	125	70	9	7
35202-29	115/230 dual	34499-6	1/2	2R626C-5BQ14	300	410	65	50
35202-35	115/230 dual	34499-6	1/2	V022C-4D020	300	270	40	20
35202-38	115	34499-8	1/3	V002C-4EJ	300	175	65	60

NOTE: Capacity in GPH @ 1725 RPM pumping #2 fuel oil @ 75° F.

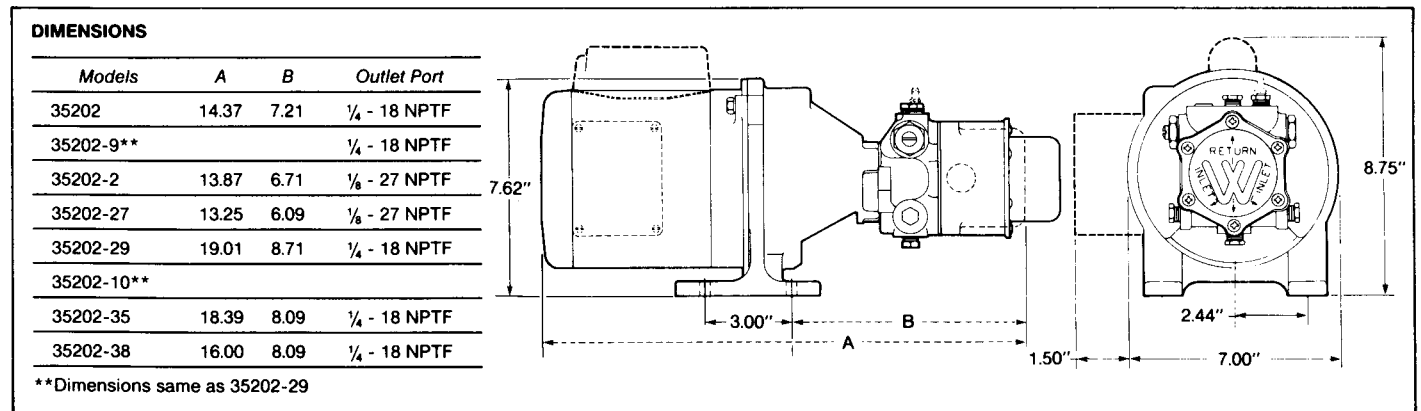

## Motor Bracket Assemblies

### MOTOR BRACKET ASSEMBLIES (MBA)

Applications requiring supply or transfer units not shown in this catalog can be easily satisfied by combining a motor bracket assembly with any Webster M or R Series fuel units or V Series pump.

MBA includes electric motor and 4 bolt bracket assembly, ready to mount fuel unit or pump.

Models	Description
MBA-16	1/6 HP, 1725 RPM, 120 V Motor and Bracket
MBA-14	1/4 HP, 1725 RPM, 120 V Motor and Bracket
MBA-13	1/3 HP, 1725 RPM, 120 V Motor and Bracket
MBA-12	1/2 HP, 1725 RPM, 120 V Motor and Bracket

## 'OSV' - Oil Safety Valve

See Bulletin FU43-4 for additional information.

See Bulletin FU43-4 for additional information.

### Two Models Available:

**OSVA 38** for 3/8" Pipe; Ports, 3/8 - 18 NPTF

**OSVA 50** for 1/2" Pipe; Ports, 1/2 - 14 NPTF

UL Listed for No. 2 or lighter fuel oil at 60 PSI maximum inlet pressure.

- Relieves pressure strain on fuel pump inlets
- Prevents syphonage of fuel tanks
- Prevents spilling due to accidental line breakage

The Webster Oil Safety Valve is ideal for use in oil supply systems which have from 0 to 60 PSI supply line pressure on the inlet side of the valve, but requires a sustained vacuum on the outlet side of the valve for the fuel to flow to the burner pump.

Many state and local codes require a device that will automatically shut off the oil supply before it enters the building should the line between the device and the burner be broken. Similar codes require that the pressure on burner pumps not exceed 3 PSI. The Webster Oil Safety Valve will satisfy both requirements.

The OSV valve has many uses: One, it can be used on pressurized fuel lines of supply pumps ahead of each burner to relieve pressure strain on the fuel pump inlets to prevent seal damage. Two, the unit can be used as an anti-syphon valve to prevent syphonage of fuel tanks due to a break in the suction line or malfunction of components. Three, it is used just before a pressurized supply line enters a building or mobile home to prevent a break or malfunction from spilling oil into the building.

**CAUTION — Do not mount the OSV more than three feet above the burner fuel pump inlet, or more than three feet above the lowest point in the fuel line connecting the OSV to the burner fuel pump. In-line mounting with the burner fuel pump inlet is recommended.**



### RECOMMENDED MAXIMUM FLOW RATES AND PRESSURE — OSV 38 and OSV 50

Flow thru Valve	Pressure at Valve Inlet, psi					
	5	15	30	40	50	60
1 gph	2.5	2.7	3.5	4.5	5.0	5.5
15 gph	2.7	3.0	4.0	5.0	5.5	6.0
32 gph	3.7	4.0	4.7	5.2	6.0	7.0
45 gph	4.0	4.5	5.0	6.0	7.0	
55 gph	4.5	5.0	5.7			
60 gph	5.0	5.2	6.0			
70 gph	5.5	6.0				Do not operate in this region

Vacuum (inches Hg) to operate valve is shown for various flow and pressure conditions.

Values given are averages of test results and may vary slightly.

---

## Limited Warranty Policy

Webster extends a limited warranty that products, manufactured by Webster, under the "Webster" Trademark, shall be free from defects in materials and workmanship for a period of three (3) years from the date of manufacture, or two (2) years from the date of installation, whichever period expires first. Webster will rebuild or replace, at its option, all products proven to its satisfaction to be defective within such limited warranty period and returned to the Webster factory in Frankfort, Kentucky, transportation charges prepaid. Webster's sole obligation and buyer's exclusive remedy hereunder is limited to such rebuilding or replacement.

No products may be returned to the Webster factory without prior written consent from Webster's Customer Service Department. This Limited Warranty does not cover shipping costs to and from the Webster factory, any costs for labor or otherwise related to product removal or replacement, or any other costs of any nature without prior written consent by Webster.

This Limited Warranty shall not apply to parts, products or accessories that have been manufactured by any company other than Webster Fuel Pumps, & Valves.

This Limited Warranty shall not apply to defects caused in any way by acts of God, war or civil insurrection, nor shall it apply to products which, in the sole discretion of Webster, have been subject to negligence, abuse, accident, misapplication, tampering or alteration. This Limited Warranty shall not apply to products which in the sole discretion of Webster have been subject to other than normal application, use or service, including but not limited to, operational failures caused by corrosion, rust or other foreign materials in the system, or operation at conditions other than those specified or recommended by Webster, including but not limited to operation at pressures in excess of recommended maximums.

Purchaser shall be solely responsible for determining suitability for use of Webster Products. This Limited Warranty does not in any way extend to determinations of suitability of use, and Webster shall not, in any event whatsoever, have any liability with respect to such determinations.

The foregoing Limited Warranty is exclusive and in lieu of all other warranties, expressed or implied, including but not limited to implied warranties of merchantability and fitness for a particular purpose. Webster shall not be liable for any consequential, incidental or contingent damages whatsoever.

### **OUR PLEDGE TO YOU:**

*When you buy Webster products, you buy total service. Webster is the unique, single-source supplier of an extensive line of heating products. We manufacture fuel units, supply and transfer pumps, valves and oil heat accessories.*

*Webster is committed to reliable service of its products. As always, our field service people provide professional schooling and make training materials and demonstration units available for training.*

*We are ready to work with you to help solve your specific heating problems. If you have any technical questions, call our toll-free HELPLINE: (800) 766-1233.*

The specifications contained in this bulletin were effective at the time of publishing. Webster reserves the right to discontinue products at any time or to change specifications or design without incurring any obligation. For current information, contact Webster sales department.

---

# Webster®

## Fuel Pumps & Valves

219 Hahn Road  
Frankfort, KY 40601  
(502) 223-0025 • (800) 766-1233  
FAX (502) 223-4629  
[www.websterfuelpumps.com](http://www.websterfuelpumps.com)

Copyright © 2002 Webster