

THE UNIQUE SURFACE-DEEP WELL PUMP COMBINATION: Your versatile and Inexpensive Deep Well Pumping Solutions easy to install and maintain !!

DEEP WELL PACKER SINGLE PIPE (2" well with leather packers) and TWIN PIPE (4" and larger diameter well) VENTURI SYSTEM JET SELF PRIMING ELECTRIC PUMPS WITH EJECTOR FOR DEEP WELL SUCTION LIFTS DOWN TO 50m - for Deep Boreholes - Conva®

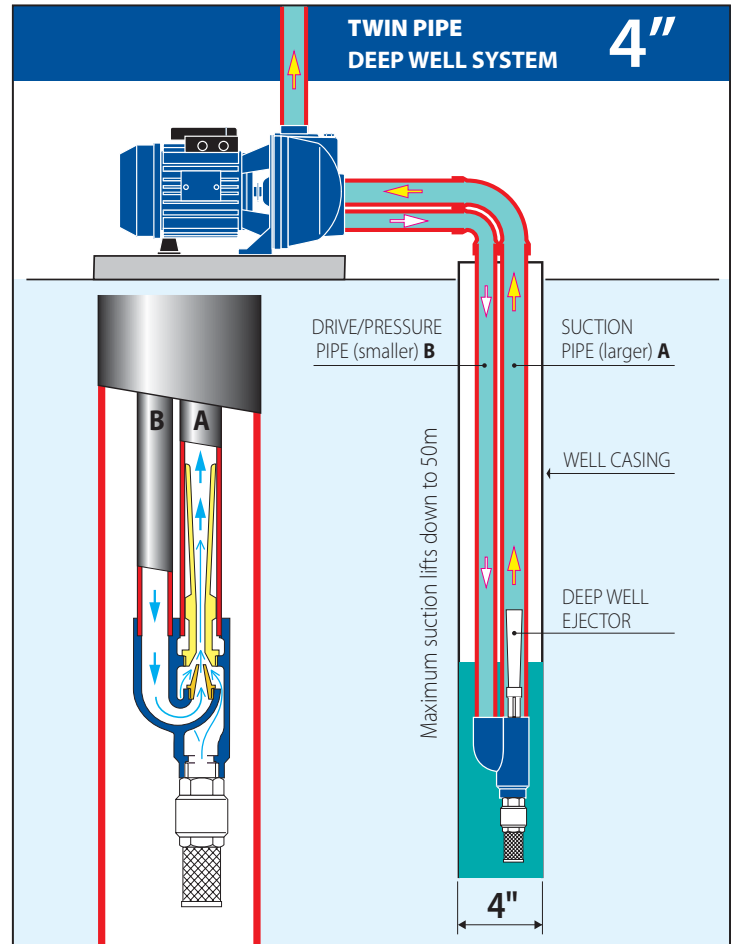
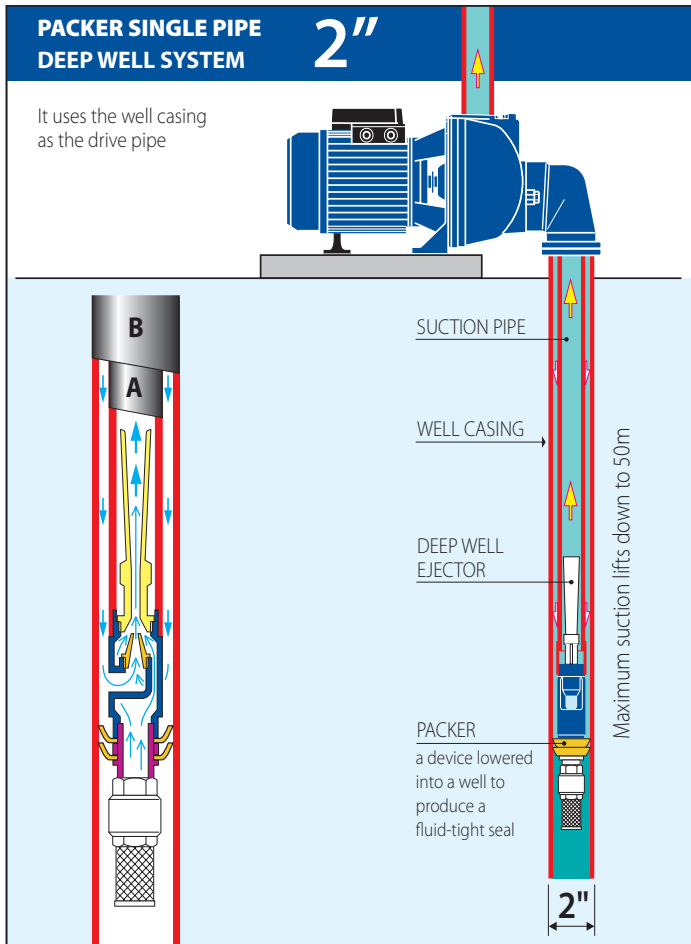

When and Where These Pumps Must be used:

they must be used in those wells where the suction lift required is deeper than 8-9m, (when a shallow well jet pump cannot be used), in any situation where the level between the pump and water supply exceeds 8-9m or for example a river or stream where the pump has to be fixed some distance away and with water level changes and in those wells where the water capacity is low, when the submersible pump is too big for the well capacity or for the well size, when to drill a bore is too difficult or expensive!! Suction Capacity down to 50m depth (underground, as far as 50 metres below the level of the installed pump and while the pump sits aboveground!). Deep Well Jet Pumps are not restricted to well or borehole application. They are equally suitable for low NPSH conditions in industry and have been used on solvents and for hot condensate.

Single pipe packer Deep Well pumps require a 2" well casing.

Twin Pipe Deep Well Pumps require a 4" well casing.

Deep well systems require a pressure control valve fitted to protect against loss of prime from over pumping and a pressure diaphragm tank.

Typical Deep Well Installations:

- Packer Single Pipe 2" with cased well
- Double Pipe 4" and larger Diameter Well with cased well: requires a two-pipe circulating system to the ejector in the well.
- Driven Point (Spear Point) well (well point or sand point installation) using a packer jet assembly in 2" diameter well with drive point and with screen
- Open water well.

DEEP WELL PACKAGE:

CHOOSE EITHER A TWIN PIPE or PACKER STYLE (with packer adapter on the wellhead).

D30 Ejector Assembly is the ideal for deeper suction depths !

• Deep well systems can also be installed in horizontally off-set situations to draw water from distant dams, rivers etc. This allows the pump to be mounted away from the source of water to gain access to power, or in places where there is the possibility of flooding: pumping system can be used for offset installations.

• Pumps can also be used in applications where pump needs to be horizontally offset from the water supply.

• Pipe: we recommend galvanized steel but PVC (plastic) is less expensive, much lighter and will never rust.

• **FOOT VALVE:** improves the performance of wells and it helps keep water close to the pump and filters large debris preventing them from entering your pump and damaging the seals.

FIT the VALCO FOOT VALVE in Acetal Resin, Ecological: it maximizes pump suction performance by reducing the friction loss and it ensures safe working without any risk of block caused from lime/scale deposit or periods of inoperation and higher resistance to corrosion, best for drinking water.

• **Make sure you protect your pump from freezing.**

• Special executions may be driven also with Petrol or Diesel Engine and Solar Energy.

DEEP WELL PACKER SINGLE PIPE (2" well with leather packers) and TWIN PIPE (4" and larger diameter well) VENTURI SYSTEM JET SELF PRIMING ELECTRIC PUMPS WITH EJECTOR FOR DEEP WELL SUCTION LIFTS DOWN TO 50m - for Deep Boreholes - Conva[®]

2"

PACKER SINGLE PIPE (2" well with leather packers) DEEP WELL JET SYSTEM - Conva[®]



4"

TWIN PIPE (4" and larger diameter well) DEEP WELL JET SYSTEM - Conva[®]



SPECIAL EXECUTIONS ON REQUEST TO SUIT THE PUMPING REQUIREMENTS OF YOUR WELL !!!

THIS IS A PUMP RANGE THAT REALLY DOES A MARVELLOUS JOB AT A VERY LOW COST !!

PACKER SINGLE PIPE (2"well with leather packers) DEEP WELL JET SYSTEM - Conva®

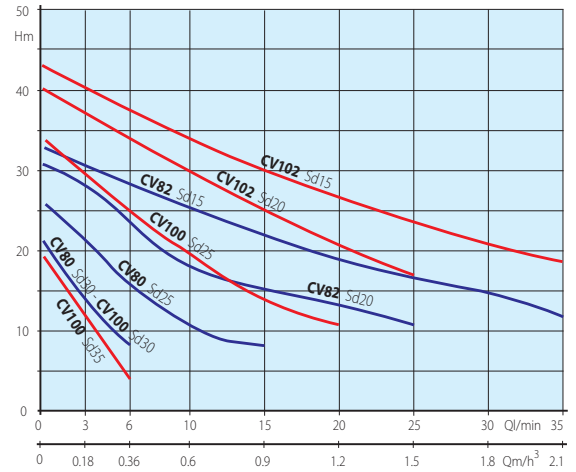
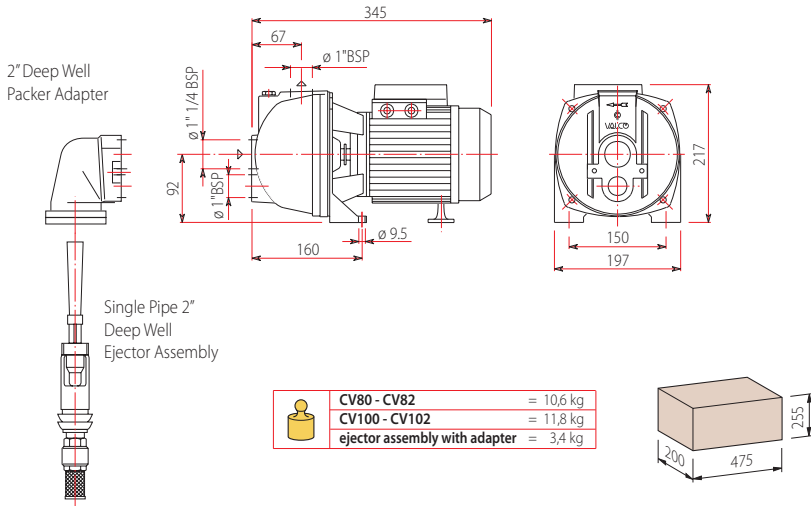

TYPES		P2 nom.		P1 max kW		A		Ejector well type	Ejector well size	Sd Suction depth m	Q= Performance at 2900 rpm									
1~ 230V 50Hz	3~ 230/400V 50Hz	HP	Kw	1~	3~	1~ 230V	3~ 400V				m³/h	0,18	0,36	0,6	0,9	1,2	1,5	1,8	2,1	3
CV80-2	CV80T-2	0,8	0,6	0,8	0,81	3,7	1,4	D30	2"	25	22	16	11	8						
CV82-2	CV82T-2	0,8	0,6	0,8	0,81	3,7	1,4	D20	2"	15	31	28	25	22	19	17	15	12		
CV100-2	CV100T-2	1	0,75	1,05	0,95	5,3	2,2	D30	2"	20	28	23	18	15	13	11				
CV102-2	CV102T-2	1	0,75	1,05	0,95	5,3	2,2	D20	2"	25	30	25	20	14	11					
										30	14	8								
										35	12	4								
										15	40	37	34	30	27	24	21	18		
										20	37	34	30	25	21	17				

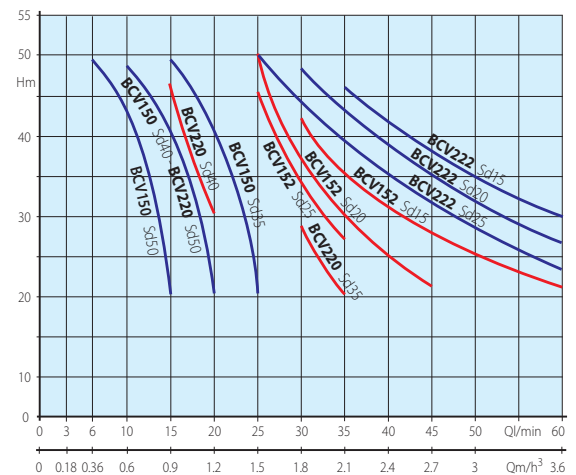
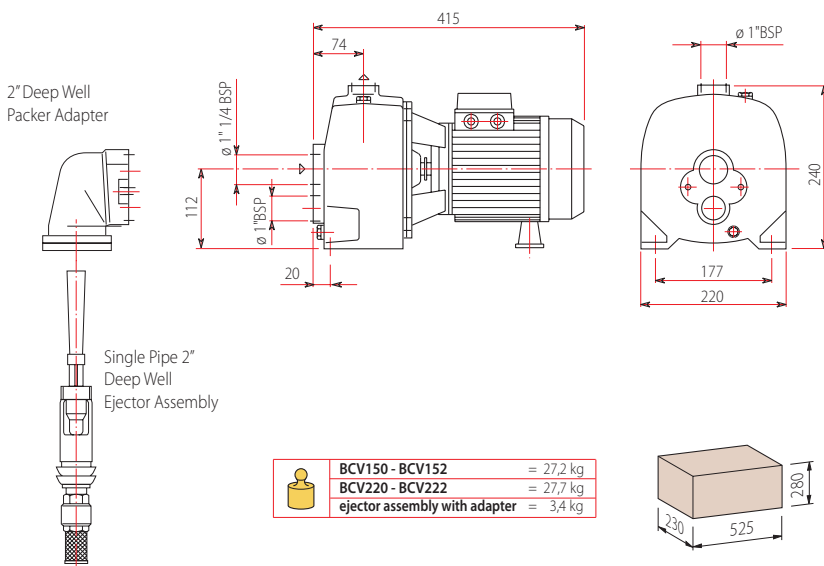

TYPES		P2 nom.		P1 max Kw		A		Ejector well type	Ejector well size	Sd Suction depth m	Q= Performance at 2900 rpm									
1~ 230V 50Hz	3~ 230/400V 50Hz	HP	Kw	1~	3~	1~ 230V	3~ 400V				m³/h	0,18	0,36	0,6	0,9	1,2	1,5	1,8	2,1	3
BCV150-2	BCV150T-2	1,5	1,1	1,65	1,65	8,2	3	D30	2"	35										
										40			48	40						
										50	49	43	20							
BCV152-2	BCV152T-2	1,5	1,1	1,65	1,65	8,2	3	D20	2"	15						42	35	25	21	
										20					50	37	30	21		
										25					45	34	27			
										35						28	20			
BCV220-2	BCV220T-2	2,2	1,65	2,22	2,22	10,3	4,1	D30	2"	40			46	30						
										50	49	40								
BCV222-2	BCV222T-2	2,2	1,65	2,22	2,22	10,3	4,1	D20	2"	15							46	35	30	
										20							48	43	32	27
										25					50	44	40	28	23	

4"

TWIN PIPE (4" and larger diameter well) DEEP WELL JET SYSTEM - Conva®

Twin Pipe 4"
Deep Well
Ejector Assembly

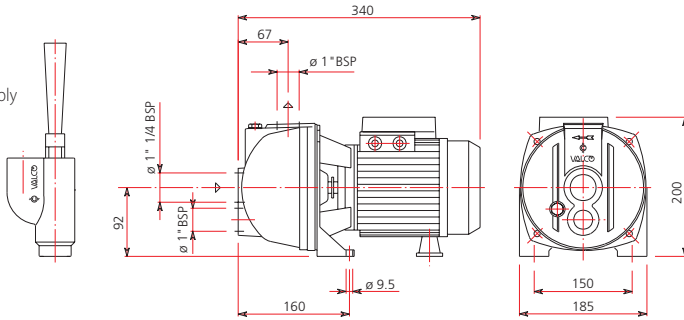

	CV80 - CV82	= 10,1 kg
	CV100 - CV102	= 11,3 kg
	ejector assembly	= 1,6 kg

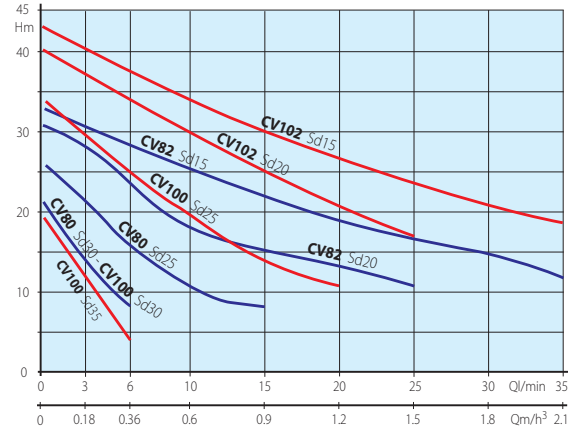
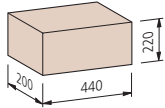

TYPES		P2 nom.		P1 max Kw		A		Ejector well type	Ejector well size	Sd Suction depth m	Q= Performance at 2900 rpm									
1~ 230V 50Hz	3~ 230/400V 50Hz	HP	Kw	1~	3~	1~ 230V	3~ 400V				m³/h	0,18	0,36	0,6	0,9	1,2	1,5	1,8	2,1	3
CV80-4	CV80T-4	0,8	0,6	0,8	0,81	3,7	1,4	D30	4"	25	22	16	11	8						
CV82-4	CV82T-4	0,8	0,6	0,8	0,81	3,7	1,4	D20	4"	15	31	28	25	22	19	17	15	12		
CV100-4	CV100T-4	1	0,75	1,05	0,95	5,3	2,2	D30	4"	20	28	23	18	15	13	11				
CV102-4	CV102T-4	1	0,75	1,05	0,95	5,3	2,2	D20	4"	25	30	25	20	14	11					
										30	14	8								
										35	12	4								
										15	40	37	34	30	27	24	21	18		
										20	37	34	30	25	21	17				

Hm = Total head in meters w.c.

Twin Pipe 4"
Deep Well
Ejector Assembly

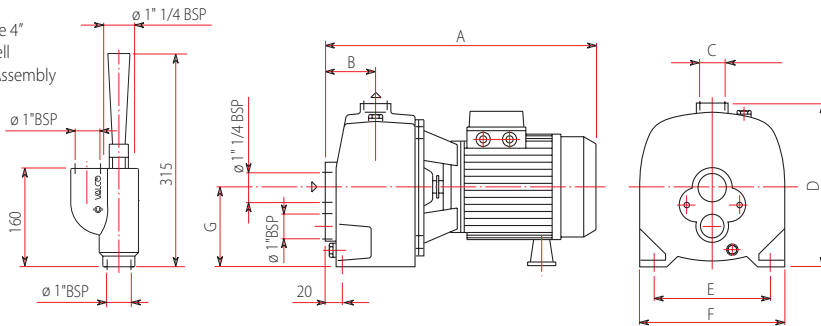

Type	A	B	C	D	E	F	L	H	P
BCV150 - BCV150T - BCV152 - BCV152T - BCV220 - BCV220T - BCV222 - BCV222T	415	74	1" BSP	240	177	220	525	280	230
BCV300 - BCV302	437	81	1" 1/4 BSP	273	190	240	470	290	275
BCV300T - BCV302T	391	81	1" 1/4 BSP	273	190	240	410	295	270

	BCV150 - BCV152	= 27,2 kg	BCV300 - BCV302	= 32,0 kg
	BCV220 - BCV222	= 27,7 kg	BCV300T - BCV302T	= 27,5 kg
	ejector assembly	= 1,6 kg	ejector assembly	= 1,6 kg

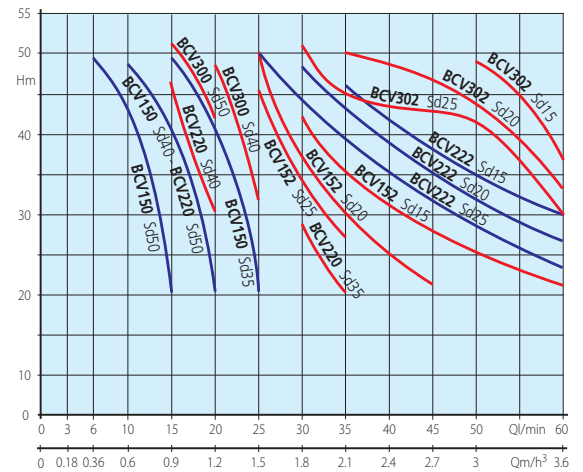
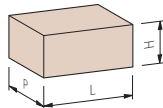

TYPES		P2 nom.		P1 max Kw		A		Ejector well type	Ejector well size	Sd Suction depth m	Q= Performance at 2900 rpm									
1~ 230V 50Hz	3~ 230/400V 50Hz	HP	Kw	1~	3~	1~ 230V	3~ 400V				m³/h	0,18	0,36	0,6	0,9	1,2	1,5	1,8	2,1	3
BCV150-4	BCV150T-4	1,5	1,1	1,65	1,65	8,2	3	D30	4"	35										
										40										
										50										
BCV152-4	BCV152T-4	1,5	1,1	1,65	1,65	8,2	3	D20	4"	15										
										20										
										25										
BCV220-4	BCV220T-4	2,2	1,65	2,22	2,22	10,3	4,1	D30	4"	35										
										40										
										50										
BCV222-4	BCV222T-4	2,2	1,65	2,22	2,22	10,3	4,1	D20	4"	15										
										20										
										25										
BCV300-4	BCV300T-4	3	2,2	2,8	2,8	13,5	5	D30	4"	40										
										50										
										15										
BCV302-4	BCV302T-4	3	2,2	2,8	2,8	13,5	5	D20	4"	20										
										25										

Hm = Total head in meters w.c.

DEEP WELL PACKER SINGLE PIPE (2"well with leather packers) and TWIN PIPE (4"and larger diameter well) VENTURI SYSTEM JET SELF PRIMING ELECTRIC PUMPS WITH EJECTOR FOR DEEP WELL SUCTION LIFTS DOWN TO 50m. For Deep Boreholes - Conva®

FEATURES

- The self priming is achieved using a **suction ejector or injector** which can be lowered into a well and connected to the pump body by one or two pipes with ejector fitted at the end of the suction pipe down the bore with min. borehole well 2-inch (packer single pipe deep well pumps) and 4-inch (twin pipe deep well pumps): flows can be provided from as deep as 50 metres, the pump being installed at ground level, thus making servicing easier. With submerged ejector fitted at the end of the suction pipe with ejectors versions suitable for min.borehole well 2-inch or 4-inch, (smaller ejector well sizes available on demand) for open wells and tube well.
- **There are no moving parts within the well, the pump being set at ground level- a feature that allows servicing without disturbing well or service piping.**

It enables the pump to be offset from the well or borehole. Neither straightness of the well or sloping ground affects operation, and the pump will also work efficiently from **sandy wells**- a major problem encountered with other types of deep well unit.

An ejector is fitted in the well or borehole and connected to the pump by twin pipes or single packer pipe; water enters the ejector and is raised to the pump by the energy of the circulating water.

Deep Well Jet Pumps are not restricted to well or borehole application.

They can be used in any situation where the level between the pump and water supply exceeds 8-9m or for example a river or stream where the pump has to be fixed some distance away.

They are equally suitable for low NPSH conditions in Industry and have been used on solvents and for hot condensate.

- As the pump is installed at ground level and there are no moving parts in the well, it is not necessary to disturb pipe below ground during servicing, thus saving time and money.
- **Excellent Air Handling Ability:** after initial priming the pump has the ability to re-prime itself even when air gets into the system (entrained air). Pumping resumes once the water level rises above the foot valve.
- Impeller, diffusor and venturi tube: in technopolymer General Electric® Noryl® GFN2V technopolymer EJECTOR UNIT (approved for drinking water), brass nozzle. Diffusor with wear ring made in stainless steel for wear resistance.
- Can draw up water in spite of presence of gas, air, or tolerable quantities of sand
- **Self priming pumps: pumps always ready for use !**

APPLICATIONS

When these pumps must be used:

- Where the pumps must be used: in those wells where the suction lift required is deeper than 8-9m and with water level changes and in those wells where the well water capacity is low; when a jet pump cannot be used (for lift suctions deeper than 8-9m: a well with a depth to water that is constantly or periodically greater than 8-9m): **this pumpset which is easy and safe has a Suction Capacity down to 50m depth (underground, as far as 50 metres below the level of the installed pump and while the pump sits aboveground !)**
- when the submersible pump is too big for the well capacity or for the well size
- when to drill a bore is too difficult or expensive
- are ideal for supplying high pressure water from well bores to 50m depth for:
 - water transfer and supply
 - booster service
 - tank filling
 - stock watering
 - sprinkler supply
 - hosing down jobs
 - garden watering and waterfalls and fountains

And many other applications !

ADVANTAGES

- **no need to drill expensive wells**
- this economical, simple, efficient and versatile pump replaces the need to install a very expensive and complicated submersible pump
- **ideal for well with low water capacity**
- **ideal for handling waters with a tolerable content of sand**
- lowest consumption of energy with highest efficiency: **energy saving**
- easy to maintain, long life, trouble free.

PUMP and MOTOR CONSTRUCTION

- cast iron pump body
- stainless steel shaft
- mechanical seals
- high quality bearings
- Impeller, diffusor and venturi tube: in technopolymer General Electric® Noryl® GFN2V technopolymer EJECTOR UNIT (approved for drinking water), brass nozzle. Diffusor with wear ring made in stainless steel for wear resistance.
- close coupled totally enclosed fan-ventilated (T.E.F.V.) 2 pole AC induction electric motor, with Class F winding and IP54 protection, (1 phase version with permanent split capacitor and with a built-in overload motor protector with automatic reset, on 3 phase version the overload motor protection must be provided by the user).

IMPORTANT

- **Check that the depth of your well, well capacity and pumping level are adequate for this pump.** The Depth of your well should be sufficient to submerge the foot valve at least 3 to 5m below the pumping level.
- **There is less and less water available in most parts of the world and consequently water is becoming more and more vital and precious and this Deep Well Pump is the Right and most competitive Pump to pump from depths the water you need and where you need it !**
- Energy to be installed, being the motor consumption very low, is minimum.
- The cost of the pump is low.
- With this range of pumps you achieve a combination of optimum Performance and Efficiency, very limited consumption of Energy at lowest possible prices !!
- **You water your Garden from a Hole in the Ground !!**
- By installing the ejector below the water level: this of particular value when you have a water level that is gradually lowering !!

INSTALLATION

IMPORTANT: Before installing the pump check that all piping is absolutely clean. A foot or a check valve must be installed in the ejector body. After the pump has been installed, fill completely both pipes and pump body with clean water. If an excessive flow rate is required at delivery, the pressure in pipe "B" may decrease and provide insufficient energy to the water in pipe "A", causing the pump to lose its prime. Fit a gate valve on the delivery pipework to calibrate output.

TAILPIPE WILL PREVENT BREAKING SUCTION:

If the capacity of a deep well jet pump exceeds the well production, well drawdown will allow your pump to break suction and lose prime. This can be overcome by using a 10m tailpipe between jet assembly and the foot valve. Since the capacity of a pump falls off as the lift is increased, your well inflow and pump output will equalize somewhere between the jet and foot valve.

RULE OF THUMB

- Deep Well Jet Pumps should always be located at highest point in the line on the suction side of the installation.
- Never Use pipes smaller than the pump suction ports.
- If offset (distance from wellhead to pump) is greater than 6m increase horizontal pipes by one size each !



WE GIVE OUR CUSTOMERS HIGH VALUE PUMPS IN TERMS OF QUALITY, TECHNOLOGICAL INNOVATION, COMPETITIVE PRICES AND BEST SERVICING !!

Some features:

- our pumps are made entirely by Valco in Italy
- high quality at honest competitive prices
- material certified for reliability and long life
- process and production cycles to ISO standards
- overdimensioned motors to handle voltage fluctuations
- single phase motors with overload
- special sealing arrangements with superior quality
- high performance
- high efficiency and consequently saving of energy due to low power consumption.

The Company was founded by Valerio Costenaro in 1976 in Marostica in the high technology region of VENETO, (Venice Region, North-east Italy). The company has flourished by the design and manufacture of an expanding range of pumps, motors and associated fittings for their installation:

- Electric Pumps: Borehole Submersible for Deep Wells, Drainage and Sewage Wastewater Submersible, Surface Centrifugal Close Coupled.
- Booster Pressurization Pumping Sets also with Variable Speed Control.
- Controls and Fittings for Pumps and Pumping Installations, (float switches, fluid level control regulators, valves in different materials to suit fluid compatibility, pressure membrane vessels, flexible hoses, water filters, pressure switches, pressure gauges, electronic pump controllers, variable speed inverters).
- Electric Motors (Compact AC Power) in Standard or Custom Designs.

An exclusive specialised distribution network supports the customers requirements.

VALCO ensures:

- High quality and high technology with competitive prices
- The best servicing
- A global strategy for the promptest delivery of spare parts in a competitive manner
- Reduction of your purchasing and transport costs
- Pumps simple to and cost effective to maintain with design for long life
- Pump arrangements to suit your individual requirements, (pumps and systems custom designed/made): our Special Pumps Division
- Constant research by our PUMP & MOTOR RESEARCH CENTRE in the development of new and more advanced products. The research and Development of pumping sets for customers individual requirements are carried out by the Special Pumps Division
- Leadership in pump and motor technology
- YOUR WATER & PUMPS SPECIALISTS, HIGH QUALITY AND COMPETITIVE PRICES: CONSULT US FOR YOUR PUMPING REQUIREMENTS.

VALCO: THE MOST COMPLETE RANGE OF PUMPS FOR DOMESTIC, AGRICULTURAL AND INDUSTRIAL USE AND A RELIABLE SOURCE OF PUMP AND MOTOR SERVICE !

PUMPS TO LAST AND TROUBLE-FREE.

We care for :

water pumping, water pumping efficiency, water pumping controls, water pumping monitoring, water pumping installations, water resources, water finding, water preservation, water quality, water recovery, low energy consumption, ecology and the environment. These are the main issues of the present and the future and Valco is deeply involved to contribute to a better future.

VALCO[®]
water is the future[®]

Exclusive High Tech Pumps for Water and Other Fluids, Motors and Controls, in Standard or Custom Designs, Made in ITALY by VALCO since 1976 worldwide.



Head Office, Works, Pump & Motor Test Laboratory Pumps and Electric Motors Research Centre.

VALCO surl

Via dell'Industria, 27-29

I-36063 MAROSTICA (Vicenza)

Veneto, (Venice Region) - EU - Italy

Ph.: +39-0424-77847

Fax: +39-0424-475806

E-Mail: valco@valco-costenaro.com

[Http://www.valco.eu](http://www.valco.eu)

This edition effective as from 1st December, 2006, supersedes all previous issues.

ref. 6.30-65.1SF-December-2006 - 6.35 Deep Well Single Pipe Packer and Twin Pipe-Conva[®]

Trademark VALCO is a registered trademark of VALCO surl. Trademarks Conva, Jetdom, Irigua, Casalunga, Vera, Dernajo, Prima, Liqua are registered trademarks of Valco surl. Noryl[®] and General Electric[®] are registered trademarks and exclusive property of General Electric Company (GE). The features and specifications herein stated are in no way binding for the manufacturer. The Company's policy is one of continuous improvement of its products and therefore the right is reserved to supply products which may differ slightly from those illustrated and described in this publication and we reserve the right to alter specifications or prices at any time without prior notice. Design: we reserve the right at any time to discontinue the manufacture of any model, or to make changes in design for product improvement, without incurring any obligation to supply or install the same product previously supplied. Drawings and any technical or commercial literature and documentation prepared by us for the customer shall be confidential property of VALCO surl, who shall at all times retain the copyright for such drawings, literature and documentation. These together with dimensions, tests and working pressures, capacity, head, efficiency, horse power with any other technical information and illustrations published by us in catalogues, printed material, online catalogues and online files and web site content and the like are published for the guidance of customers but are only approximations and shall not become a term of any subsequent contract between us and the customer. Customers who require precise indications may obtain these, where applicable, from us. Dimensions in mm. Faoria de pompe, maneghe, tronbe e mati e muturi a elettrizar. Reproductions even partial not permitted. Reduction in speed will result in a fall of performance. Performance given are for near sea installations practical suction lift at sea level is 7,62m. Deduct 30cm of suction lift for each 300m of elevation above sea level. Data not binding. Reproduction even partial not permitted. Copyright © 1976-2007 by VALCO surl. All rights reserved.

VALCO PUMPS