

Please read and save this Repair Parts Manual. Read this manual and the General Operating Instructions carefully before attempting to assemble, install, operate or maintain the product described. Protect yourself and others by observing all safety information. The Safety Instructions are contained in the General Operating Instructions. Failure to comply with the safety instructions accompanying this product could result in personal injury and/or property damage! Retain instructions for future reference.

# **SHERTECH®** Pedestal-Mount Centrifugal Pumps

## **316 Stainless Steel, Bronze and Cast Iron Models**

Refer to form L-4077 for General Operating and Safety Instructions and Applicable Warranty.

### **Description**

Shertech pedestal cast iron, bronze or 316 stainless steel units pump continuously, producing high flow rates under low-head conditions. Designed for continuous low-pressure circulation and transfer of non-flammable liquids, utility, boiler feed, general transfer, filtration, cooling towers, condensate return, marine applications, fountains, boosters, water circulation, irrigation, spraying systems, jockey pump service, chemical processing, aggressive liquid applications and other general-purpose pumping compatible with pump component materials where no suction lift or no self-priming is required.

- Capacities to 170 GPM, heads to 74 ft.
- 1/3 to 3 HP AC requirements (motors not included).
- Clog-resistant, semi-open metallic impellers.
- Pumps feature maintenance-free ball bearings and an easily accessible front drain plug for draining liquid.
- Maximum casing working pressure is 200 PSI.
- 3/4" to 2" female NPT inlet and outlet ports.
- Discharge port can be rotated at 90-degree intervals.
- Standard pump models (at 3450 RPM) will handle specific gravities to 1.1 (at 100 SSU or less). For specific gravities to 1.4 (at 100 SSU or less), increase motor HP by one size but not to exceed standard 3 HP motor at 3450 RPM or 65 in.-lbs. of torque maximum. Higher specific gravity fluids are not recommended.
- Standard pump models (at 3450 RPM) will handle viscosity to 100 SSU (at 1.1 specific gravity or less) and up to 200 SSU (specific gravity of 1.0 or less). For viscosity up to 400 SSU (specific gravity of 1.0 or less), increase motor HP by one size but not to exceed standard 3 HP motor at 3450 RPM or 65 in.-lbs. of torque. For fluids with a viscosity greater than 400 SSU, pump speed must be reduced below 3450 RPM.
- Cast Iron and Bronze units handle temperatures to 200° F; Stainless Steel units handle temperatures to 250° F.
- Seals: Pumps are equipped with a carbon ceramic mechanical seal having 316 stainless steel components. These seals protect the pump shaft, which is 316 series stainless steel, from chemical exposure. Buna-N seal & o-ring in cast iron and bronze models, with Viton seal & o-ring in 316 stainless steel models. Aftermarket options listed below.

**SHERTECH CLOSE-COUPLED PUMPS** – Motor-driven models with NEMA 56J motor frame and base are available.

**REPAIR SEALS AND OPTIONS** – Standard (Viton & Buna-N) and an upgraded (Silicon Carbide) seal are available. If abrasive or small, particulated fluids are being pumped, an upgrade to the silicon carbide mechanical seal with Viton elastomers is recommended. Standard and upgraded seals can be located in the repair parts list pages in this manual.



**Do not use to pump flammable or explosive fluids such as gasoline, fuel oil, kerosene, etc. Do not use in flammable and/or explosive atmospheres. When pumping hazardous or dangerous materials, use only in room or area designated for that purpose. For your protection, always wear proper clothing, eye protection, etc. in case of any malfunction. For proper handling techniques and cautions, contact your chemical supplier, insurance company and local agencies (fire dept., etc.). Failure to comply with this warning could result in personal injury and/or property damage.**

# SHERTECH® Pedestal-Mount Centrifugal Pumps

## 316 Stainless Steel, Bronze and Cast Iron Models

### Model Ordering Codes and Options

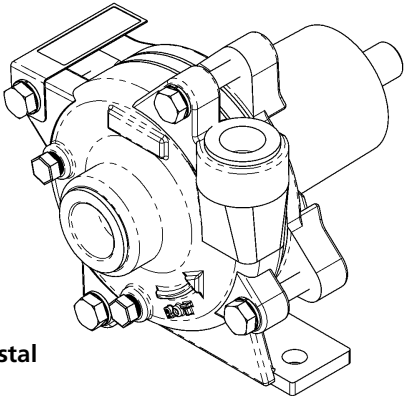

P: Pedestal

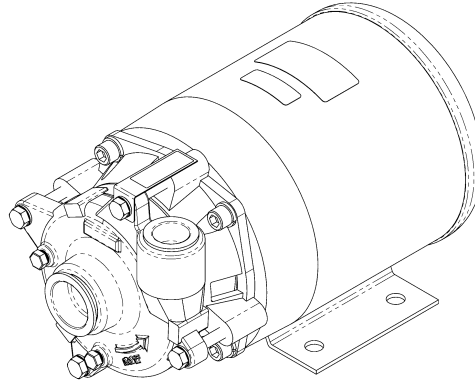

M: Motor (with base)

**Example Model: COPSV4** (will require 1 HP ODP motor with >1.15 Service Factor\*)  
(motor not supplied with pedestal pump)

(1) CO    (2) P    (3) S    (4) V    (5) 4    (6)    (7)

1st	2nd	3rd	4th	5th	6th	7th
Series	Mounting	Material	Seal** (Mech)	Impeller Sz. (NPT Ports)	Motor-Mounted Only	
					HP	AC Type
CO: Centrifugal Semi-Open Impeller	M: Motor (with Base) P: Pedestal	S: 316 SS Body and Impeller B: Bronze Body and Impeller C: Cast Iron Body and Impeller	B: Buna-N (Stainless Steel Case) C: Viton (Stainless Steel Case) (Silicon Carbide Seal and Seat Faces) V: Viton (Stainless Steel Case)	1 (¾" - 1") 2 (1" - 1¼") 3 (1" - 1½") 4 (1¼" - 1½") 5 (1½" - 1½") 6 (1½" - 1½") 7 (1½" - 2")  <i>To identify your impeller size see chart on page 12.</i>	1: 1/3 2: 1/2 3: 3/4 4: 1 5: 1½ 6: 2 7: 3  X: 56J Frame Motor "wet-end kit" Example: COMSV1X	Blank: no code single phase ODP motor 3: 3 phase ODP motor T: 1 phase TEFC 3T: 3 phase TEFC

**NOTE:** Not all order code combinations (configurations) are standard models available from the manufacturer. Custom model configurations may require ordering standard components and/or optional parts that will need to be assembled by the customer.

Manufacturer reserves the right to change model order codes, standard models, specifications, and performance without notification.

(\*) ODP motors have > 1.15 service factors. Due to service factor, it is recommended TEFC motors are oversized by one HP increment. Pedestal Pumps are not supplied with a motor.

(\*\*) Unless otherwise noted, seal faces are carbon on ceramic.

# 316 Stainless Steel, Bronze and Cast Iron Models

## Performance – Standard Models (Water at 70°)

316 SS Models	Bronze Models	Cast Iron Models	HP**	3450 RPM Pump Driven Speed										Max. Head
				10	15	GPM of water at Total Head in Feet*								
						20	30	40	50	60	70	80		
COPSV1	COPBB1	COPCB1	1/3	41	37	34	25	10	-	-	-	-	44	
COPSV3	COPBB3	COPCB3	3/4	72	68	63	53	41	22	-	-	-	55	
COPSV5	COPBB5	COPCB5	1½	115	110	104	94	81	64	40	-	-	67	
COPSV7	COPBB7	COPCB7	3	168	164	155	148	137	124	110	80	40	83	

316 SS Models	Bronze Models	Cast Iron Models	HP**	2800 RPM Pump Driven Speed										Max. Head
				10	15	GPM of water at Total Head in Feet*								
						20	30	40	50	60	70	80		
COPSV1	COPBB1	COPCB1	1/4	33	30	28	20	8	-	-	-	-	29	
COPSV3	COPBB3	COPCB3	1/2	58	55	51	43	33	18	-	-	-	36	
COPSV5	COPBB5	COPCB5	1	93	89	84	76	66	52	32	-	-	44	
COPSV7	COPBB7	COPCB7	2	136	133	126	120	111	101	89	65	32	55	

316 SS Models	Bronze Models	Cast Iron Models	HP**	1725 RPM Pump Driven Speed										Max. Head
				10	15	GPM of water at Total Head in Feet*								
						20	30	40	50	60	70	80		
COPSV1	COPBB1	COPCB1	1/4	21	19	17	13	5	-	-	-	-	11	
COPSV3	COPBB3	COPCB3	1/3	36	34	32	27	21	11	-	-	-	14	
COPSV5	COPBB5	COPCB5	1/2	58	55	52	47	41	32	20	-	-	17	
COPSV7	COPBB7	COPCB7	3/4	84	82	78	74	69	62	55	40	20	21	

SS = Stainless Steel

(\*) Test data taken with water at 70° F (to convert data to PSI, divide feet of head by 2.31).

Pump performance when pump is new. As pump wears, the performance will decrease.

(\*\*) AC HP required at specified RPM is HP rated to handle up to 100 SSU at full flow, with a maximum specific gravity of 1.1, or up to 200 SSU at 1.0 specific gravity or less.

**NOTES:** Max. Viscosity = For viscosity up to 400 SSU (at 1.0 specific gravity or less), increase motor HP by one size but not to exceed standard 3 HP motor at 3450 RPM or 65 in.-lbs. of torque. For fluids with a viscosity greater than 400 SSU, pump speed must be reduced below 3450 RPM.

Max. Casing PSI = 200 Max. RPM = 3450

Max. Specific Gravity = up to 1.1 for standard models (at 100 SSU or less); HP must be increased by one size for specific gravities up to 1.4.

Driver data is subject to change without notice; see label on driver for actual specifications.

Manufacturer reserves the right to change performance without notification.

# **SHERTECH®** Pedestal-Mount Centrifugal Pumps 316 Stainless Steel, Bronze and Cast Iron Models

## Specifications – Standard Models

Model	DRIVER		Port Size FNPT	PUMP CONSTRUCTION (Wet End)					Ship Wt. (lbs.)
	Shaft Dia.	Pedestal Base		Shaft	Housing	Impeller	Body	Seals*	
<b>316 Stainless Steel Models</b>									
COPSV1	5/8"	CI	1" x 3/4"	316 SS	316 SS	316 SS	316 SS	Viton	12
COPSV3	5/8"	CI	1 1/4" x 1"	316 SS	316 SS	316 SS	316 SS	Viton	13
COPSV5	5/8"	CI	1 1/2" x 1 1/4"	316 SS	316 SS	316 SS	316 SS	Viton	17
COPSV7	5/8"	CI	2" x 1 1/2"	316 SS	316 SS	316 SS	316 SS	Viton	21
<b>Bronze Models</b>									
COPBB1	5/8"	CI	1" x 3/4"	316 SS	BR	BR	BR	Buna-N	12
COPBB3	5/8"	CI	1 1/4" x 1"	316 SS	BR	BR	BR	Buna-N	13
COPBB5	5/8"	CI	1 1/4" x 1 1/4"	316 SS	BR	BR	BR	Buna-N	17
COPBB7	5/8"	CI	2" x 1 1/2"	316 SS	BR	BR	BR	Buna-N	21
<b>Cast Iron Models</b>									
COPCB1	5/8"	CI	1" x 3/4"	316 SS	CI	CI	CI	Buna-N	12
COPCB3	5/8"	CI	1 1/4" x 1"	316 SS	CI	CI	CI	Buna-N	13
COPCB5	5/8"	CI	1 1/2" x 1 1/4"	316 SS	CI	CI	CI	Buna-N	17
COPCB7	5/8"	CI	2" x 1 1/2"	316 SS	CI	CI	CI	Buna-N	21

SS = Stainless Steel BR = Bronze CI = Cast Iron.

(\*) Shaft Seal also contains 316 stainless steel, ceramic, and carbon components.

**NOTE:** Manufacturer reserves the right to change specifications without notification.

# 316 Stainless Steel, Bronze and Cast Iron Models

## Dimensions (inches)

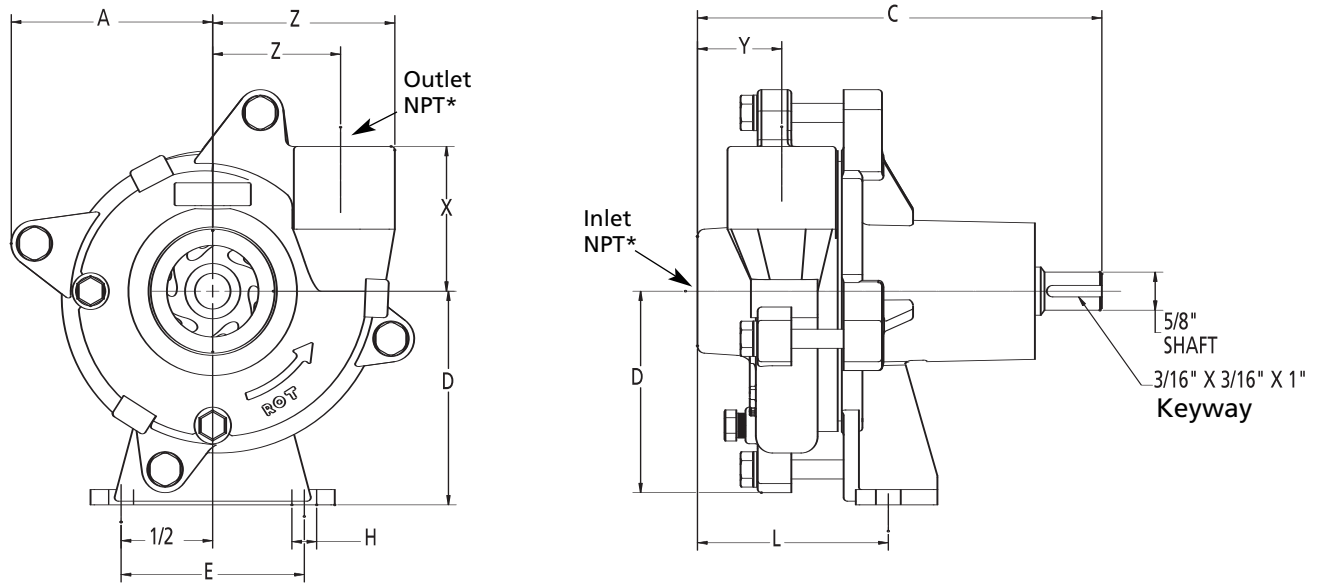

Figure 1

## Specifications

Model	Inlet*	Outlet*	CP	AB	D	DD	E	H	L	X	Y	Z	ZZ
COPSV1	1"	3/4"	6.66	2.84	3.5	2.843	3	.406	3	1.875	1.437	1.875	2.656
COPSV3	1 1/4"	1"	6.63	3.31	3.5	3.312	3	.406	3.125	2.375	1.375	2.093	2.968
COPSV5	1 1/2"	1 1/4"	6.78	3.44	3.5	3.437	3	.406	3.687	2.5	1.406	2.031	3.062
COPSV7	2"	1 1/2"	7.72	3.56	3.5	3.562	3	.406	4.187	3.5	1.593	2.875	4.25
COPBB1	1"	3/4"	6.66	2.84	3.5	2.843	3	.406	3	1.875	1.437	1.875	2.656
COPBB3	1 1/4"	1"	6.63	3.31	3.5	3.312	3	.406	3.125	2.375	1.375	2.093	2.968
COPBB5	1 1/2"	1 1/4"	6.78	3.44	3.5	3.437	3	.406	3.687	2.5	1.406	2.031	3.062
COPBB7	2"	1 1/2"	7.72	3.56	3.5	3.562	3	.406	4.187	3.5	1.593	2.875	4.25
COPCB1	1"	3/4"	6.66	2.84	3.5	2.843	3	.406	3	1.875	1.437	1.875	2.656
COPCB3	1 1/4"	1"	6.63	3.31	3.5	3.312	3	.406	3.125	2.375	1.375	2.093	2.968
COPCB5	1 1/2"	1 1/4"	6.78	3.44	3.5	3.437	3	.406	3.687	2.5	1.406	2.031	3.062
COPCB7	2"	1 1/2"	7.72	3.56	3.5	3.562	3	.406	4.187	3.5	1.593	2.875	4.25

(\*)Standard NPT (female) pipe thread.

NOTE: Dimensions have a tolerance of  $\pm 1/8"$ .

# SHERTECH® Pedestal-Mount Centrifugal Pumps

## 316 Stainless Steel, Bronze and Cast Iron Models

### Installation Guidelines

**⚠ WARNING** *Make certain that the unit is disconnected from the power source before attempting to service or remove any components! Do not exceed 3600 rpm operating speed.*

1. Pumps should not be directly driven by engines.
2. Never use a rigid coupling between a pump and its driver (electric motor, gas engine, etc.). Some degree of flexibility must be allowed to avoid excessive side loading of the drive and pump bearings.
3. Flexible couplings should be rated for the horsepower load and speed.
4. The pump and drive shaft must be properly aligned. Misalignment will cause unnecessary loads on the pump and driver bearings. Shims may be used to assist in flexible coupling of the pump to the motor.
5. Check the impeller for proper rotation. When viewing the pump inlet, the impeller should rotate counterclockwise. Test the motor or drive for correct rotation as indicated on the pump housing prior to placing the pump in service.

**⚠ DANGER** *Safety shields are required and must be mounted and kept in place while power is supplied to pump drive.*

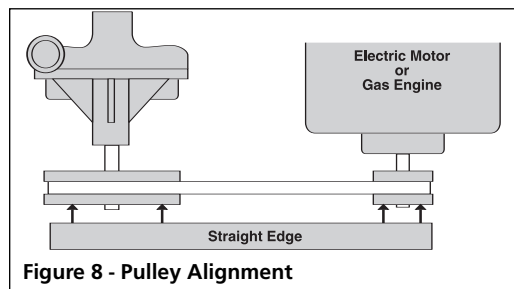

Figure 8 - Pulley Alignment

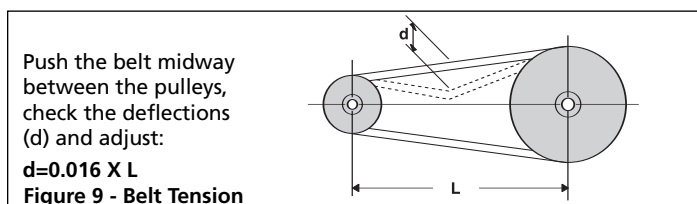

Figure 9 - Belt Tension

### Belt/Pulley Drive Installation

1. For pulley driven pumps, a single 1/2" [12.7 mm] (A or 4L section) "V" belt is satisfactory for drive sizes and speed up to 1 HP, 3450 RPM. For larger sizes, double "V" belts are recommended.
2. Mount pulleys as close to the pump and motor engine shaft bearings as possible. Check alignment with a straight edge as shown in Figure 9. Make sure the belt is properly adjusted. Too much tension will cause bearing failure and too little tension will result in belt slippage (See Figure 9). Check with the belt and pulley suppliers for specific information and recommendations.
3. To calculate the proper diameter of the pump pulley, multiply the motor/engine RPM by the diameter of the motor/engine pulley and divide that figure by the desired pump speed.

$$\text{Pump Pulley Size} = \frac{\text{Motor RPM} \times \text{Motor Pulley Size}}{\text{Desired Pump Speed}}$$

4. A safety shield (belt shield) must be installed over the pump and motor shafts, pulleys and belt.

**NOTE:** Refer to pump performance charts to determine the desired speed to obtain the desired maximum flow.

### Direct Drive – Flexible Coupling Installation

1. Slide the flexible coupling ends onto the motor/engine and pump shafts as far as possible (See Figure 10).
2. Secure but do not tighten the engine/motor and pump to the selected base or location.
3. Laser alignment of the pump shaft and the engine/motor shaft is recommended. If this is not possible, determine the parallel misalignment of the pump shaft and engine/motor shaft by placing a straight edge across the shaft and measuring the maximum offset around the periphery of the shafts. Make the necessary corrections to keep the shafts within the parallel misalignment limits (0.015").
4. When aligned, slide the flexible coupling ends over the flexible coupling center; then secure the flexible coupling ends to the motor/engine and pump shafts (See Figure 10).
5. Tighten the fasteners securing the pump and engine/motor in the desired location.
6. A safety shield (coupling guard) must be installed over the pump and motor shafts and coupling.

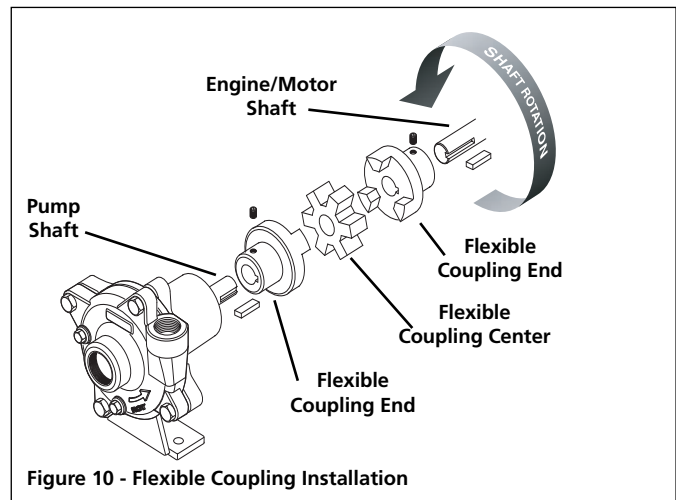

Figure 10 - Flexible Coupling Installation

## Contact a Shertech Distributor

Distributors can be found at [www.shertech.com](http://www.shertech.com) or [www.hyproindustrial.com](http://www.hyproindustrial.com)

**(The factory only sells pumps and parts to distributors.)**

Please provide following information:

- Model number
- Serial number (if any)
- Part description and number as shown in parts list

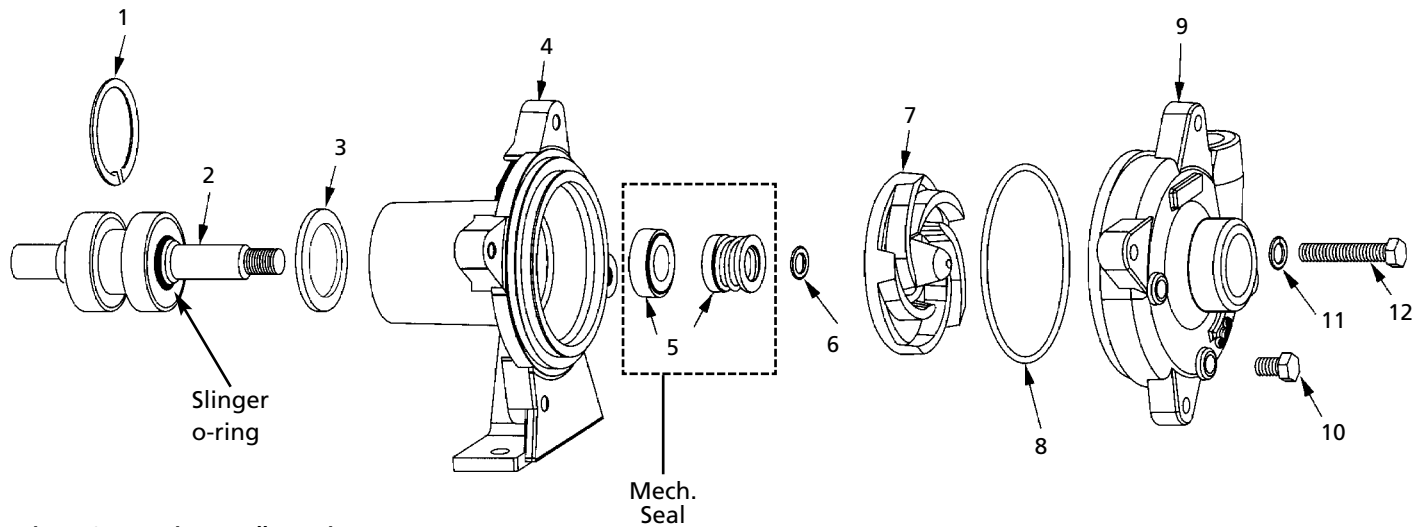

Figure 2 – Repair Parts Illustration

# SHERTECH® Pedestal-Mount Centrifugal Pumps

## 316 Stainless Steel, Bronze and Cast Iron Models

### Repair Parts List

Ref. No.	Description	316 Stainless Steel Units				Bronze Units				Cast Iron Units				Qty
		COPSV1	COPSV3	COPSV5	COPSV7	COPBB1	COPBB3	COPBB5	COPBB7	COPCB1	COPCB3	COPCB5	COPCB7	
1	Retaining ring	19942	19942	19942	19942	19942	19942	19942	19942	19942	19942	19942	19942	1
2	Shaft assembly (316 SS shaft)	23471	23471	23471	23471	23471	23471	23471	23471	23471	23471	23471	23471	1
3	Spacer	23544	23544	23544	23544	23544	23544	23544	23544	23544	23544	23544	23544	1
4	Centrifugal body	23302S	23303S	23304S	24473S	23302B	23303B	23304B	24473B	23302C	23303C	23304C	24473C	1
5	Seal & Seat Assy, Viton (Standard)	24276S	24276S	24276S	24276S	-	-	-	-	-	-	-	-	1
	Seal & Seat Assy, Buna-N (Standard)	-	-	-	-	24275S	24275S	24275S	24275S	24275S	24275S	24275S	24275S	1
	† Seal & Seat Assy, Viton	-	-	-	-	24276S	24276S	24276S	24276S	24276S	24276S	24276S	24276S	
	† Seal & Seat Assy, Buna-N	24275S	24275S	24275S	24275S	-	-	-	-	-	-	-	-	
	† Silicon Carbide Seal & Seat Assy	2120-0039S	2120-0039S	2120-0039S	2120-0039S	2120-0039S	2120-0039S	2120-0039S	2120-0039S	2120-0039S	2120-0039S	2120-0039S	2120-0039S	
6	Shim Kit	24503	24503	24503	24503	24503	24503	24503	24503	24503	24503	24503	24503	1
7	Impeller	24444S	24446S	24448S	23312	24444B	24446B	24448B	15847	24444C	24446C	24448C	15970	1
8	O-ring, Viton (Standard)	23361	23362	23543	18047	-	-	-	-	-	-	-	-	1
	O-ring, Buna-N (Standard)	-	-	-	-	22848	22849	22889	18046	22848	22849	22889	18046	1
	† O-ring, Buna-N	22848	22849	22889	18046	-	-	-	-	-	-	-	-	
	† O-ring, Viton	-	-	-	-	23361	23362	23543	18047	23361	23362	23543	18047	
9	Centrifugal housing	22858S	22859S	22860S	23364	22858B	22859B	22860B	15837	22858C	22859C	22860C	15837	1
10	Drain plug <sup>1</sup> *	24441	24441	24441	24441	00336	00336	00336	00336	23182	23182	23182	23182	2
11	Lock washer <sup>2</sup> *	23402	23402	23402	N/A	23402	23402	23402	N/A	23402	23402	23402	N/A	4
12	5/16-18 Hex head bolt <sup>2</sup> *	23389	23389	23389	N/A	23389	23389	23389	N/A	23389	23389	23389	N/A	4
	7/16-14 Long hex head bolt <sup>2</sup> *	N/A	N/A	N/A	23426	N/A	N/A	N/A	23426	N/A	N/A	N/A	23426	2
	7/16-14 Short hex head bolt <sup>2</sup> *	N/A	N/A	N/A	23392	N/A	N/A	N/A	23392	N/A	N/A	N/A	23392	1

SS = Stainless Steel

(†) Optional

(1) Drain plug material is 316 Stainless Steel for 316 Stainless Steel models, Brass for Bronze models and Zinc-Plated Steel for Cast Iron models.

(2) Material is Stainless Steel for 316 Stainless Steel models, Zinc-plated Steel for all other models.

(\*) Standard hardware item, available locally.

(\*\*) Viton and Buna-N seals have carbon on ceramic faces.

Silicon carbide seals have Viton bellows.  
All seals have 316 SS metal components.



# 316 Stainless Steel, Bronze and Cast Iron Models

## Maintenance

**⚠ WARNING** *Make certain that the unit is disconnected from the power source before attempting to service or remove any components!*

### REMOVAL OF OLD SEAL ASSEMBLY

Should the mechanical seal (Ref. No. 5) require repair, proceed as follows and refer to Figures No. 2 thru 7.

**IMPORTANT:** Always replace both the seal seat and seal as an assembly to ensure proper mating of components!

1. Remove bolts (Ref. No. 12) connecting the casing housing (Ref. No. 9) to the body (Ref. No. 4).
2. Remove the casing housing (Ref. No. 9).

**⚠ CAUTION** *Care should be taken not to pinch or "shave" the o-ring gasket (Ref. No. 8) between the body and the casing housing.*

3. Remove the impeller (Ref. No. 7).

**NOTE:** Pump shaft must be held in place to remove impeller.

**IMPORTANT:** Care should be taken to ensure that the same number and thickness of shim washers (Ref. No. 6) are replaced behind the impeller as was removed. The shim washers are located directly behind the impeller and become loose as the impeller is removed.

4. The seal (part of Ref. No. 5) can now be pulled from the shaft. (See figure 4).
5. Remove the retaining ring (Ref. No. 1) and press the shaft assembly (Ref. No. 2) out of the body. Take care not to damage the impeller threads.
6. Use a wooden dowel to push out the seal seat (part of Ref. No. 5) from the body (Ref. No. 4) (See figure 5).

### INSTALLATION OF NEW SEAL ASSEMBLY

**⚠ CAUTION** *The precision carbon/ceramic faces on the mechanical seal are easily damaged. Handle your repair seal carefully. Do not touch the carbon/ceramic seal faces.*

**IMPORTANT:** Be sure that shaft shoulder does not damage carbon face.

1. Thoroughly clean all surfaces of the seal seat cavity in body (Ref. No. 4).
2. Using a clean cloth, wipe the shaft and shaft sleeve and make certain that they are perfectly clean.

**NOTE:** Inspect the shaft for scratches or spiral grooves. If they exist, replace shaft assembly (Ref. No. 2).

3. Wet the rubber portion of the new seal seat (part of Ref. No. 5) with a light coating of soapy water. While wearing clean gloves or using a clean light rag, press seal seat squarely into body recess (Ref. No. 4). Use the cardboard washer (usually supplied with new seal) to place over the polished ceramic surface and use a piece of pipe or dowel rod to press in firmly but gently (See figure 6). Avoid scratching the ceramic face, usually white.

4. Dispose of cardboard washer. Check again to see that ceramic surface is free of dirt and all other foreign particles and that it has not been scratched or damaged.

5. Install the pump shaft assembly (Ref. No. 2). Replace the retaining ring (Ref. No. 1). Be careful not to damage the seal seat when sliding over the pump shaft.
6. Wet the inside rubber portion of the new seal (part of Ref. No. 5) with a light coating of soapy water. Slide seal onto the pump shaft with the precision sealing surface (carbon) facing the seal seat ceramic face (See figure 7). This completes seal installation.

**NOTE:** A short "run-in" period may be necessary to provide completely leakproof seal operation.

7. Screw impeller (Ref. No. 7) onto shaft. To hold the shaft from turning, clamp with a web wrench to prevent marring the shaft. A drop of removable thread lock should be applied to the impeller threads. Impeller should be torqued

to 15 to 18 ft-lbs. (180 to 210 in lbs.)

8. By replacing the original shims that came with the pump, the impeller height should be properly set. The chart accompanying figure 3 gives the correct body to impeller height dimension for optimum pump performance. After installing, check if shaft turns freely by spinning impeller. If rubbing or binding is found, remove impeller and add a shim (Ref. No. 6) to shaft, then recheck. Repeat procedure until all rubbing is eliminated.
9. Place o-ring (Ref. No. 8) on pump body. Attach housing (Ref. No. 9) using bolts (Ref. No. 12) being careful not to pinch or "shave" o-ring. As the housing is being tightened, periodically spin impeller to check

**⚠ CAUTION** for interference with housing.

*Seal assembly will produce minor drag when spinning drive shaft, but rubbing anywhere else must be eliminated! Otherwise, damage to pump and/or motor may occur.*

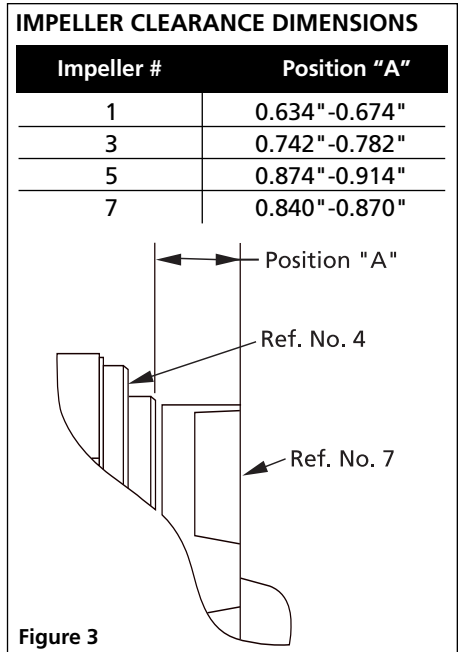

Figure 3

# **SHERTECH<sup>®</sup> Pedestal-Mount Centrifugal Pumps**

## **316 Stainless Steel, Bronze and Cast Iron Models**

### **Seal Assembly Removal and Installation (Figures 4 thru 7)**

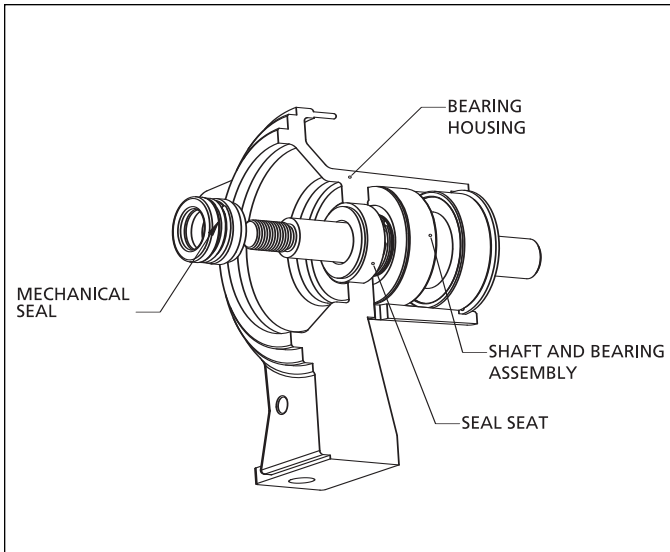

Figure 4 - Seal Removal

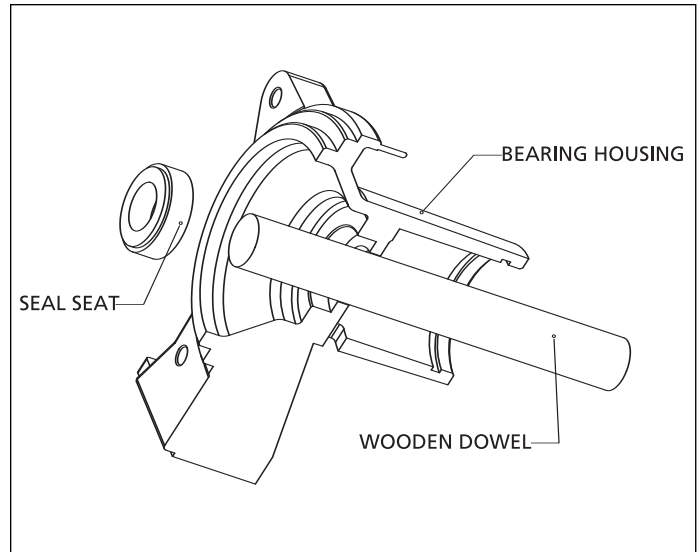

Figure 5 - Seal Seat Removal

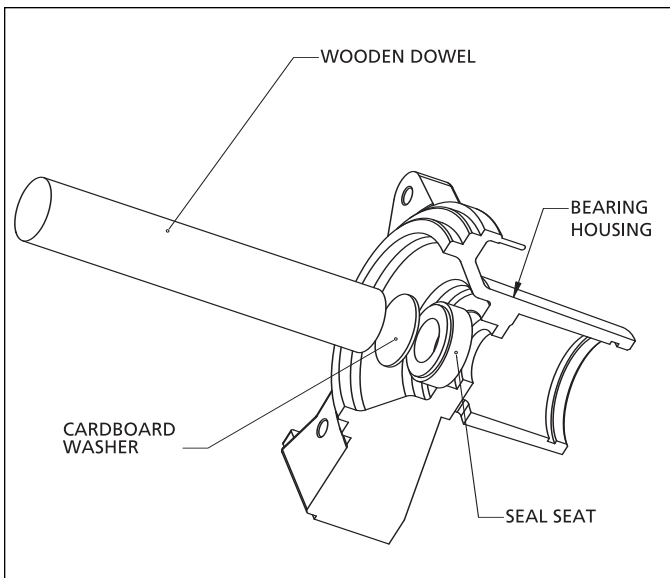

Figure 6 - Seal Seat Assembly

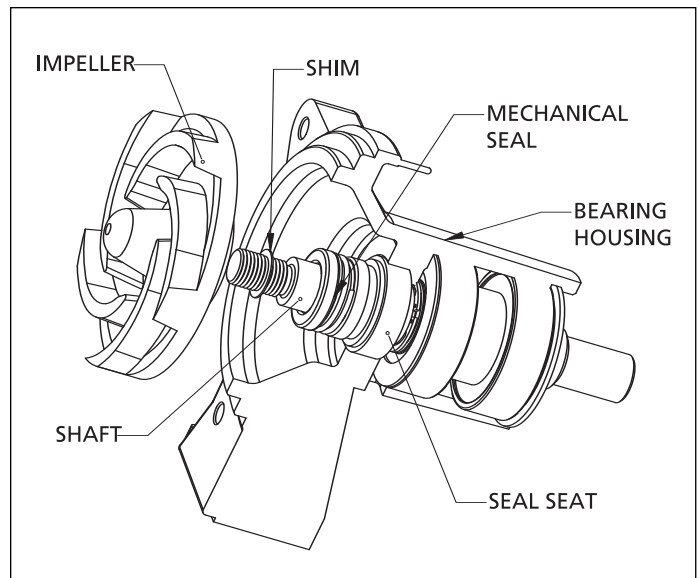

Figure 7 - Seal and Impeller Assembly

# 316 Stainless Steel, Bronze and Cast Iron Models

## Troubleshooting Chart

Symptom	Possible Cause(s)	Corrective Action
Pump runs but no fluid	<ol style="list-style-type: none"> <li>1. Faulty suction piping</li> <li>2. Pump located too far from fluid source</li> <li>3. Gate valve closed</li> <li>4. Clogged strainer</li> <li>5. Fouled foot valve</li> <li>6. Discharge height too great</li> <li>7. Suction lift too great</li> </ol>	<ol style="list-style-type: none"> <li>1. Replace</li> <li>2. Relocate</li> <li>3. Open</li> <li>4. Clean or replace</li> <li>5. Clean or replace</li> <li>6. Lower the height</li> <li>7. Lower pump</li> </ol>
Pump will not prime or retain prime after operating	<ol style="list-style-type: none"> <li>1. Air leak in suction line</li> <li>2. Clogged foot valve or strainer</li> <li>3. Leaking foot valve</li> </ol>	<ol style="list-style-type: none"> <li>1. Repair or replace</li> <li>2. Clean or replace</li> <li>3. Repair or replace foot valve</li> </ol>
Pump starts and stops pumping	<ol style="list-style-type: none"> <li>1. Fouled impeller</li> <li>2. Faulty mechanical seal</li> <li>3. Leak in suction line</li> <li>4. Leak in foot valve</li> </ol>	<ol style="list-style-type: none"> <li>1. Clean</li> <li>2. Replace</li> <li>3. Repair</li> <li>4. Repair or replace</li> </ol>
Flow rate is low	<ol style="list-style-type: none"> <li>1. Incorrect speed</li> <li>2. Piping is fouled or damaged</li> <li>3. Clogged impeller or worn impeller</li> <li>4. Discharge line restricted or undersized</li> <li>5. High discharge pressure</li> </ol>	<ol style="list-style-type: none"> <li>1. Check drive</li> <li>2. Clean or replace</li> <li>3. Clean or replace</li> <li>4. Flush out piping or replace</li> <li>5. Check and reduce</li> </ol>
Excessive noise while pump in operation	<ol style="list-style-type: none"> <li>1. Pump not secured to firm foundation</li> <li>2. Piping not supported to relieve strain on pump assembly</li> <li>3. Restricted suction line</li> <li>4. Cavitation (noise like marbles in pump)</li> </ol>	<ol style="list-style-type: none"> <li>1. Secure properly</li> <li>2. Make necessary adjustments</li> <li>3. Clean or correct</li> <li>4. a. Reduce speed b. Increase inlet size c. Too viscous (thickness of material being pumped too large)</li> </ol>
Liquid drips from point where shaft enters the pump casing when pump is full of liquid	<ol style="list-style-type: none"> <li>1. Damaged mechanical seal</li> <li>2. Liquid being pumped is over 200°F on Cast iron or Bronze and 250°F on Stainless Steel</li> </ol>	<ol style="list-style-type: none"> <li>1. Replace (See Mechanical Seal Replacement)</li> <li>2. Lower fluid temperature</li> </ol>
Pump runs but poor performance	<ol style="list-style-type: none"> <li>1. Check pump rotation to see if it is CCW as viewed from motor face. On three-phase motors, rotation must be checked prior to running pump under load.</li> </ol>	<ol style="list-style-type: none"> <li>1. On three-phase motors, switch any two motor wire leads to reverse rotation.</li> </ol>

**⚠ WARNING** Failure to check rotation before pump is run can result in severe damage to the pump and motor unit.

# **SHERTECH®** Pedestal-Mount Centrifugal Pumps 316 Stainless Steel, Bronze and Cast Iron Models

## Impeller Identification Chart

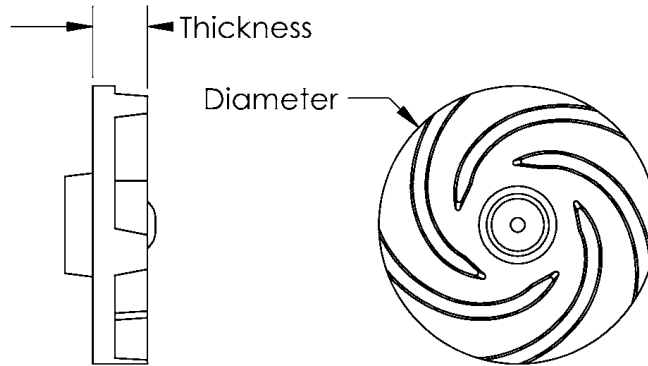

## Impeller Identification Chart

Impeller Number	HP Required	316SS Part#	Brass Part#	Cast Iron Part#	Diameter inches	Thickness inches
1	1/3	24444S	24444B	24444C	3.38	0.60
2	1/2	24445S	24445B	24445C	3.50	0.71
3	3/4	24446S	24446B	24446C	3.63	0.71
4	1	24447S	24447B	24447C	3.90	0.83
5	1-1/2	24448S	24448B	24448C	4.25	0.83
6**	2	23311	18021	19569	4.57	0.52
7**	3	23312	15847	15970	4.63	1.11

NOTES: \*\*Tapered impellers  
All impellers are semi-open.

**SHERTECH®**



**Pentair Water  
INDUSTRIAL PRODUCTS GROUP**

375 Fifth Avenue NW • New Brighton, MN 55112  
Phone: (651) 766-6300 • 800-471-0460 • Fax: 800-672-7023  
[www.shertech.com](http://www.shertech.com) • [www.hyproindustrial.com](http://www.hyproindustrial.com)