

RotoTM
pumps

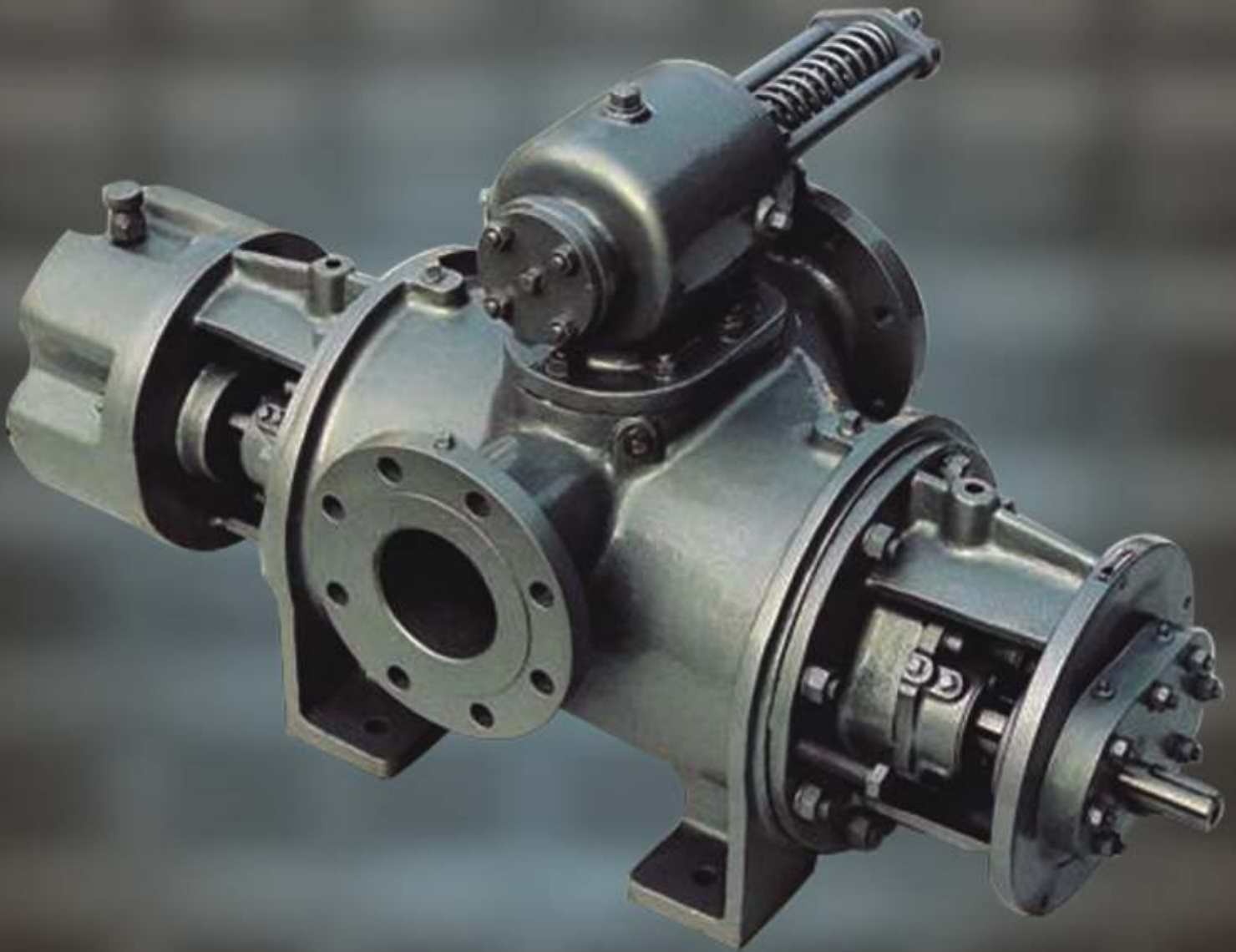

Twin Screw Range of Pumps

Roto
pumps 40+^{years of}
moving fluids positively



PUMPING PRINCIPLE

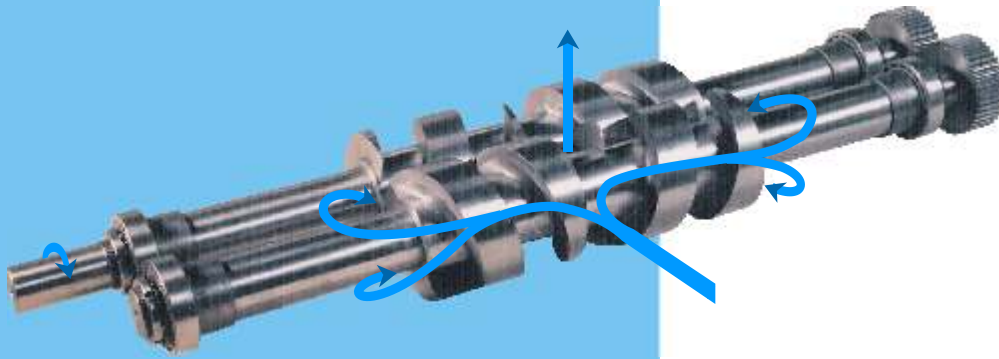

The working principle of Roto gear timed Dual-Flow Twin Screw Pumps is dependent on the rotation of two screw spindles in closed compartment. Wherein a pre-defined clearance is maintained between the screw spindles as well as between the outside diameter of the screw spindles and the bore of the casing/liner in which the screw spindles are located. Each half of the screw spindles is left-handed and right-handed. Thus when the spindles start rotating, driven by a pair of timing-gears located at the end of the screw spindles, the liquid is drawn towards the end of the screw spindles and entrapped between the bore of the pumping compartment as well as the flanks of the screws and is then propelled axially from both the ends towards the centre. Such a dual flow nullifies the axial thrust completely thereby enabling the screw spindles to remain in a state of hydraulic balance. Roto's unique double profile of the screw spindles contributes to a higher volumetric efficiency, thus an improved overall efficiency.

SALIENT CHARACTERISTICS

- Long and trouble-free service life
 - Due to absence of metal to metal contact between the pumping elements. Can even run dry for limited period of time
- No axial thrust
 - Dual flow of liquid in opposite direction balances axial thrust
- Higher volumetric efficiency
 - Due to special double profile of screw flanks
- High cavitation free suction lift
 - Due to low NPSH (R)
- Self-priming and capable of handling entrapped air/vapour/gas
 - Due to positive displacement action and being inherently self-priming
- Uniform metered flow
 - Being a positive displacement pump, head developed is independent of speed and capacity is approximately proportional to speed
- Capable of handling wide variety of Fluids
 - Lubricating/non-lubricating as well as aggressive liquids can be handled due to choice of different designs and material of construction
- Safe to operate
 - Has in-built relief valve designed to bypass upto 100% capacity
- Wider conformity to API 676, 2nd edition

INTERNATIONAL QUALITY



Continuous investments in precision measuring instruments, state-of-the-art testing facility and a dedicated team of engineers are testimony to Roto's commitment to maintain and constantly upgrade the quality of its products. The system of quality assurance at Roto guarantees compliance with numerous national/International standards. The manufacturing units are certified for conformance to the ISO 9001-2000 quality surveillance systems.



CERTIFICATE NO. A14319 ISO 9001-2000



CROSS SECTION OF TWIN SCREW PUMP

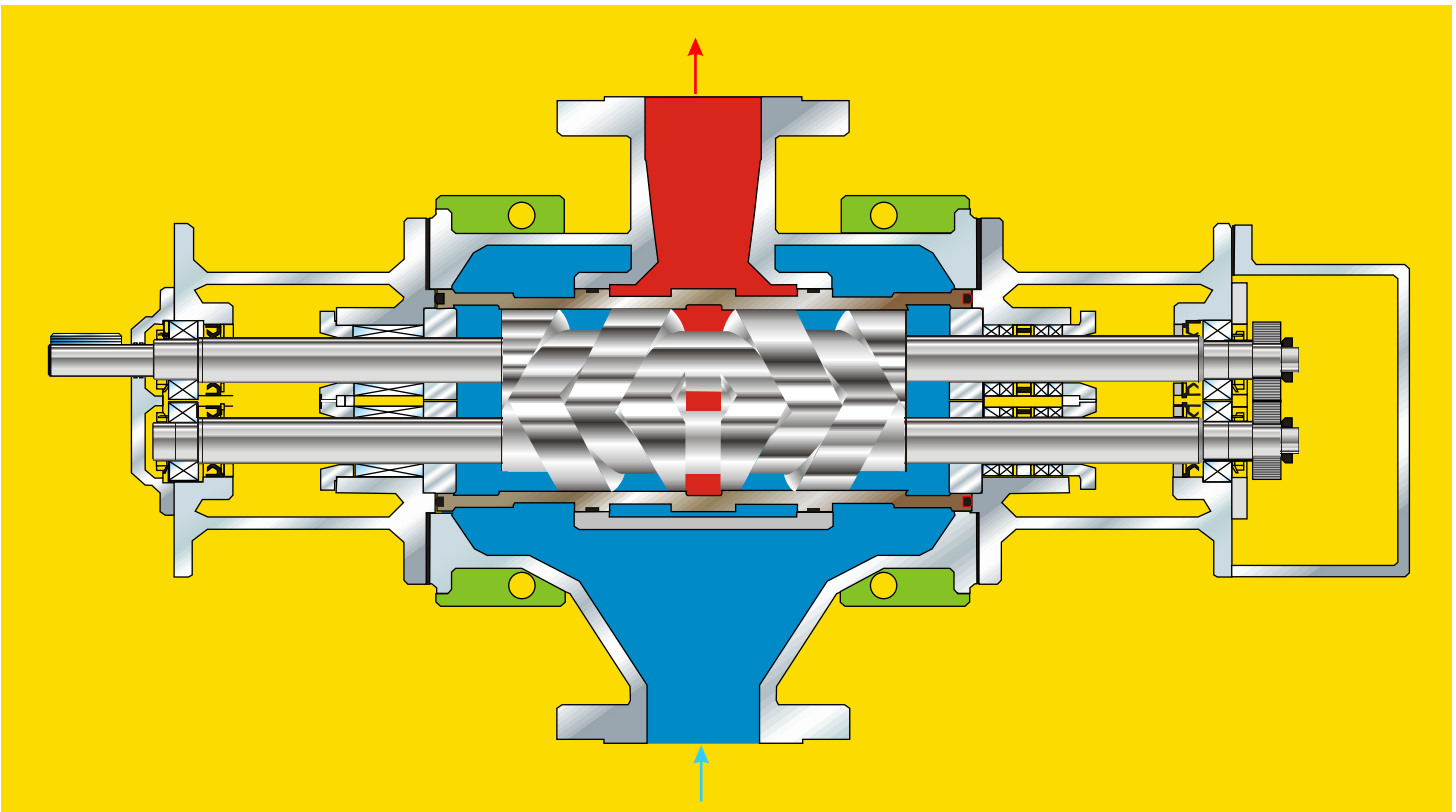

CONSTRUCTIONAL FEATURES

Roto Twin Screw Pumps are available, as a standard, with renewable liners and in-line suction and discharge branches. Pumps can be configured both in Internal bearing as well as External bearing design to suit liquid characteristics with the option for sump heating. External bearing pumps can be completely jacketed or made suitable for electrical tracing. Shaft sealing options are soft gland packing/mechanical seals. Special hygienic constructions are also available. And to suit liquid medium a wide choice of construction material are available.



INDUSTRIES SERVED

Petrochemicals & Refinery, Oil Exploration, Oil Distribution Depots, Bunkering Stations, Power Plants, Marine & Ship Building, Sugar, Steel Plants, Paper, Liquid Terminals, Bulking Stations, Man made fibre, Paint, Fertilizer, Food Processing, Edible Oil, Cosmetics, Soap & Detergent, Distillation Plants, Mineral Processing etc.

FLUIDS HANDLED

Fuel Oil, LSHS, HPS, RFO, Crude Oil, Vacuum Residue, Slack Wax, Bitumen, Mineral Oil, Turbine Oil, Hydraulic Oil, LDO/HSD, Kerosene Oil, Avcat Fuel Oil, Naptha, Lubricating Oils, Fire Fighting Foam Solutions, Molasses, Black Liquor, Polymeric Resins, Paints, Lacquers, Plasticisers, Cosmetic Creams, Detergents, Soaps, Glucose, Jelly, Fats, Creams, Chocolate, Palm Oil, Alcohols, Esters, Viscose, Vegetable Oil, Caustic Lye, Asphalt etc.





DESIGN VARIANTS

Horizontal External Bearing Pumps



Performance Data

Capacity	500 M ³ /Hr
Temperature	350°C
Pressure	40 Bar
Viscosity	upto 1,00,000 Cst

These pumps are available in standard foot mounted & centre line mounted configuration with or without steam jacketing, sump heating, electrical/ steam tracing arrangement as an option.

Vertical Pumps



Horizontal Internal Bearing Pumps



Performance Data

Capacity	500 M ³ /Hr
Temperature	100°C
Pressure	40 Bar
Viscosity	upto 10,000 Cst

These pumps are available in standard foot mounted configuration with sump heating arrangement as an option.

Performance Data

Capacity	500 M ³ /Hr
Temperature	Internal Bearing upto 100°C External Bearing upto 350°C
Pressure	40 Bar
Viscosity	Internal Bearing upto 10,000 Cst External Bearing upto 1,00,000 Cst

These pumps are available in standard foot mounted configuration with steam jacketing arrangement as an option.

MATERIAL OF CONSTRUCTION

Housing Components : Cast Iron, Cast Steel, Cast Stainless Steel

Liner : Cast Iron, Cast Stainless Steel

Screws: Alloy Steel, Nitrided Steel & Stainless Steel

Timing Gears: EN 36/EN 24

Gear Box : Cast Iron, Aluminium

Special Execution : In addition to the material construction listed above, Roto Twin Screw Pumps can also be supplied with pump body in welded steel construction along with renewable liners of suitable material. For abrasive and/or corrosive applications, the screw and the pump body can be supplied with special coating for better wear and corrosion resistance.

Roto also undertakes skid mounted pumping systems complete with piping and instrumentation.

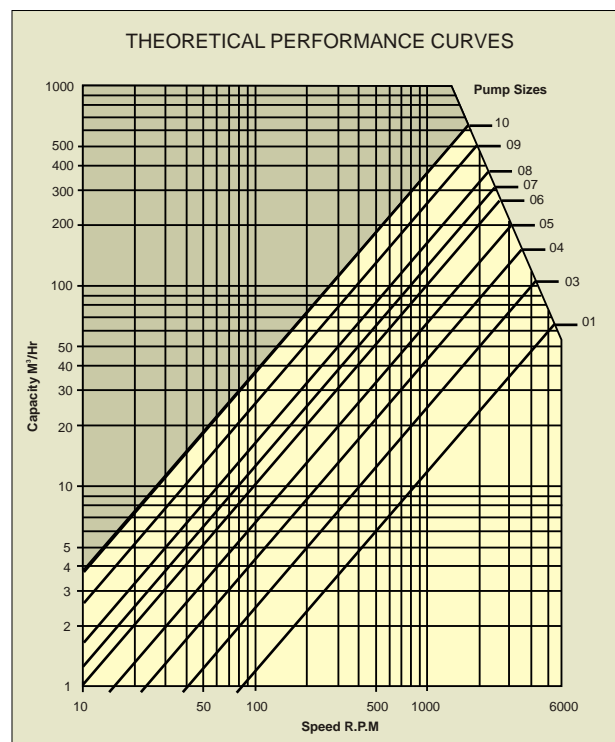



BUILT-IN SAFETY RELIEF VALVE

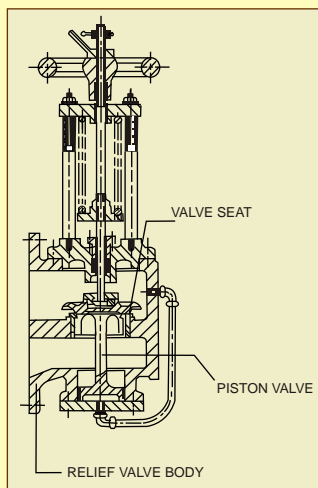

Roto twin screw pumps being positive displacement type, should never be run against a closed delivery valve or any other delivery line blockage. To prevent such an occurrence for safety to the pump as well as the system, Roto Twin Screw Pumps incorporate as a standard, a safety relief valve capable of 100% bypass of fluid. Whenever low pressure pump applications are involved, pilot valve connection is provided to ensure 'chatter free' operation of the relief valve. A typical safety relief valve illustration is shown here.

SHAFT SEALINGS

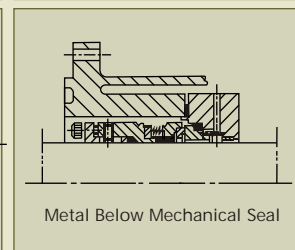
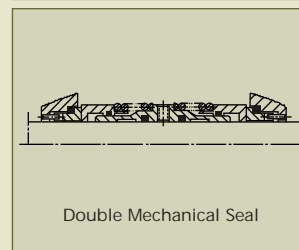
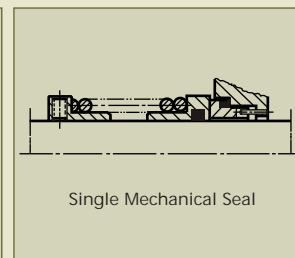
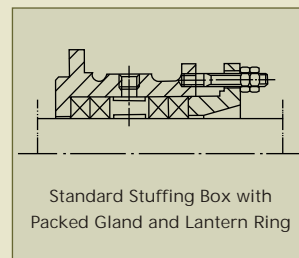

KEY INSTALLATIONS



Pumping Lube Oil at Lube Oil Blending Plant in Haldia, India



Pumping Chemical at a facility in Malaysia



Pumping Molasses at a facility in Vietnam



Pumping Black Liquor at a facility in Turkmanistan



Pumping Crude Palm Oil at a facility in Haldia, India



Pumping resins at a facility in Kolkata, India



Pumping Carbon Black Feed Stock at a facility in Egypt



Pumping Viscose at a facility in Indonesia



Pumping Bitumen at a facility in Tehran, Iran



Roto's Manufacturing Plant

Strong Manufacturing Base

Roto's new integrated manufacturing plant with an in-house Polymer unit and its other plant at Duty Free Zone are spread over 20,000 sq. mtrs. The plants have sophisticated machine tools & testing facilities that ensure a consistent world-class quality matching today's demanding customer expectations. All critical components are manufactured in-house to ensure 100% quality conformance. Roto's state-of-the-art R&D facility translates concepts to prototypes and prototypes into final products. Headed by some of the world's finest pump professionals, it is equipped with a battery of solid H stations and sophisticated Test beds with Data Acquisition & Analysis System to ensure comprehensive validation of pump design.

Roto's world class products are available through its own Warehouse - Marketing offices at Australia and U.K. and strong network of dedicated distributors spread across the globe.

Over 40 years of fluid engineering expertise

Roto's application expertise has been gained over four decades in providing fluid engineering solutions to more than 4000 customers world-wide. The Roto excellence spanning over 1500 types of fluids, is a valuable asset for you to bank upon for more efficient and cost effective solutions to your fluid handling requirements.



U.K. Office



Plant at Duty Free Zone



Australia Office

ROTO PUMPS LTD.

Website: www.rotopumps.com

Marketing Head Office

Roto House, Noida Special Economic Zone, Noida - 201305, India
Tel.: +91 120 3043901-4 Fax.: +91 120 2562561. E-mail: contact@rotopumps.com

International branches

UNITED KINGDOM - E-mail: sales@rotopumps.co.uk AUSTRALIA - E-mail: melb@rotopumps.com.au

Domestic branches

CHENNAI	-	Phone : (044)28546606	Fax : (044)28591002	E-mail : rotochn@rotopumps.com
HYDERABAD	-	Phone : (040)40027606	Fax : (040)40027649	E-mail : rotohyd@rotopumps.com
KOLKATA	-	Phone : (033)22821943	Fax : (033)22826304	E-mail : rotocal@rotopumps.com
MUMBAI	-	Phone : (022)22694604	Fax : (022)22659681	E-mail : rotomum@rotopumps.com
VADODARA	-	Phone : (0265)2344954	Fax : (0265)2344936	E-mail : rotobrd@rotopumps.com