

# Wastewater

## UP16M Series



163025  
C SA US  
CSA 108  
UL 778

### Applications

Manually operated Submersible Utility pump ideal for dewatering and water transfer

### Features

- **SOLIDS HANDLING CAPABILITY** - 1/8".
- **MOTOR** - 1/6 HP, 115 volt, thermal overload protected. 2.1 full load amps. 10 foot power cord. Stainless steel heat treated shaft. Continuous duty "oil free" motor. Lubricated lip seal.
- **PUMP CASING** - Corrosion resistant aluminum for superior heat dissipation. 3/4" NPT discharge.
- **IMPELLER** - Constructed of durable glass reinforced thermoplastic.
- **GARDEN HOSE ADAPTER** - For convenient hook up.
- **BOTTOM SUCTION DESIGN** - Built-in suction strainer to eliminate internal damage from possible debris. Removable filter screen for easy cleaning.

## Dimensional Outline

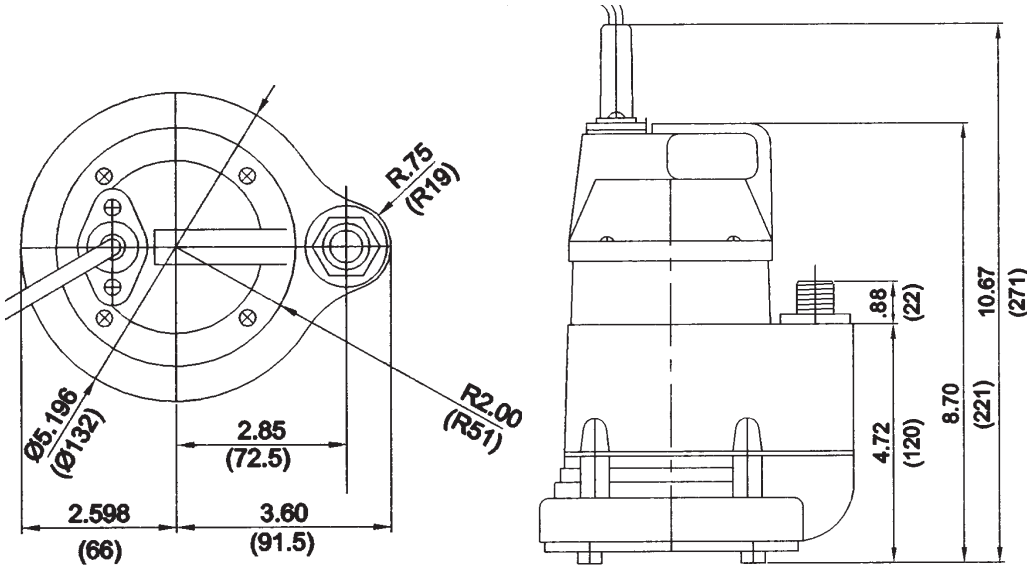

\*Dimensions measured in inches [mm]

## Specifications

Model No.	Item No.	Listing	HP	Volts	Discharge	Total Head in Feet			Shut-Off Head (ft.)	Cord Length (ft.)	Ship Wt. (lbs.)
						5	10	15			
						Capacities in U.S. GPM					
UP16M	620137	cCSAus	1/6	115	3/4"	20	14	7	19	10	3

## Performance Data

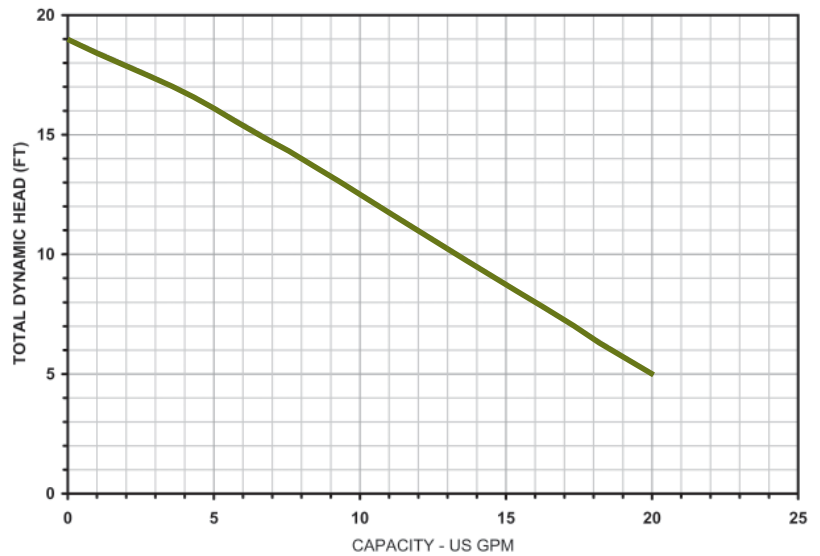

**Franklin Electric**

P.O. Box 12010  
 Oklahoma City, OK 73157-2010  
 Phone: 1.800.701.7894  
 Fax: 1.800.678.7867  
 www.LittleGiantPump.com

©2009 Franklin Electric Co., Inc.  
 Little Giant® is a registered trademark of Franklin Electric Co., Inc.  
 Form 995736 - 05/09