

# Industrial

## TSP Series

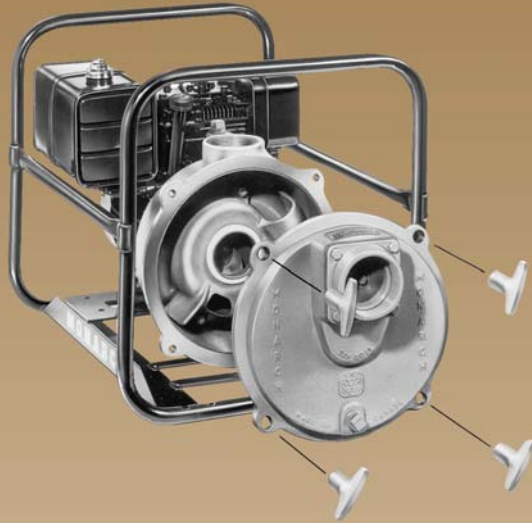

TSP-4V



TSP-3HRF

### Applications

Fast self priming trash pump series; comparable in weight to aluminum pumps. Ideal for portable trash pumping and hydro-seeding applications. Handles spherical solids up to half the diameter of the suction hose. The pump casing is built of cast ductile iron for durability. Available in 2", 3" & 4" sizes.

### Features

- **ENGINE** – A variety of gasoline engines available.
- **SEAL** – Siliconized Graphite corrosion and abrasion resistant, water lubricated, no maintenance required on a replaceable sleeve, protecting engine shaft.
- **PRIMING PLUG** – Enables priming without the removal of the discharge hose.
- **DISCHARGE OUTLET** – Threaded female NPT.
- **IMPELLER** – Semi-open cast gray iron, two vane type, for higher efficiency, capable of handling spherical solids.
- **DIFFUSER** – Ductile iron, replaceable, with built-in wear plate.
- **CHECK VALVE** – Built-in with threaded NPT suction inlet, prevents syphoning, facilitates priming.
- **CASING** – Rugged ductile iron construction for high impact resistance and long life.
- **"O" RING SEAL** – No gaskets required.
- **SUCTION STRAINER** – Price of pump includes a suction strainer, designed to pass solids of size that can be handled by pump, giving an unobstructed flow.
- **FRONT COVER** – Ductile iron construction - easy removal by four wing nuts, no wrenches required.
- **DRAIN PLUG** – Enables casing to be drained, for winterizing, prevents frost damage.
- **ROLL FRAME** – Sturdy welded roll frame standard on 2" and 3" models only.



MONARCH

**Little GIANT®**  
Pumps. People. Partnerships.

## Dimensional Outline

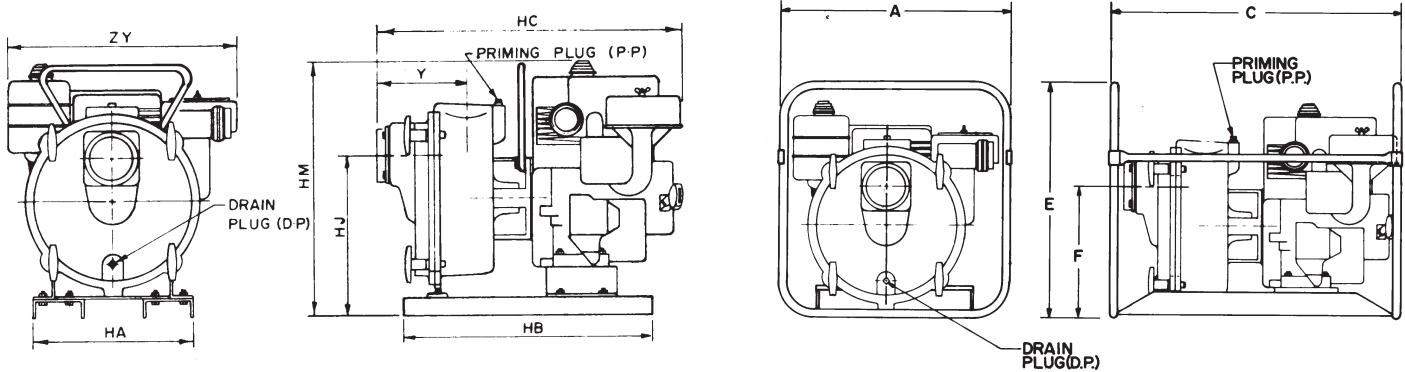

Model No.	HP	HA	HB	HC	HJ	HM	ZY	Y	A	C	E	F
TSP-2HRF	5 1/2	-	-	-	-	-	-	-	20.40	25.00	21.50	11.50
TSP-3HRF	9	-	-	-	-	-	-	-	20.40	25.00	21.50	11.50
TSP-4V	18	16.18	25.00	32.00	17.81	24.00	20.09	12.00	-	-	-	-

\*Dimensions measured in inches

## TSP Series Trash Pumps

Model No.	Item No.	Suct. NPT	Solids Handling	Flow Capacity U.S. GPH	Total Head (ft.)	Max Suct. Lift (ft.)	Disch. NPT	Engine	HP	Fuel Tank Cap. (gal.)	Run Time (hrs.)	Low Oil Shut Off	Ship Wt. (lbs.)
TSP-2HRF	611107	2"	1 1/8"	11,500	100	25	2"	Honda 6X160	5 1/2	0.80	1.65	YES	107
TSP-3HRF	611108	3"	1 1/2"	20,000	75	25	3"	Honda 6X270	9	1.30	2.2	YES	151
TSP-4V	611123	4"	2"	37,000	90	25	4"	Vanguard	18	2.2	1.5	NO	355

\* Equipped with electric start. Battery and cables not included.

## Performance Data

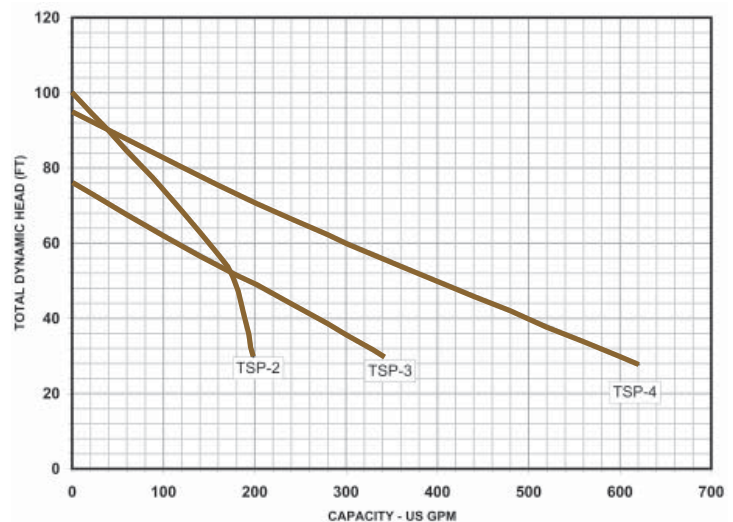

P.O. Box 12010  
 Oklahoma City, OK 73157-2010  
 Phone: 1.800.701.7894  
 Fax: 1.800.678.7867  
 www.LittleGiantPump.com

©2009 Franklin Electric Co., Inc.  
 Little Giant® is a registered trademark of Franklin Electric Co., Inc.  
 Form 995734 — 04/09