

Fluid-o-Tech "Syrup" oscillating piston pumps



The "Syrup" version of the Fluid-o-Tech "Mono" oscillating piston pump is equipped with custom components, specifically designed to grant supreme performance and a high degree of compatibility with most of the syrups present in the market today with a viscosity up to 400 cSt.

The innovative sealing system, the new piston highly resistant to corrosion and mechanical wear and the improved precision of the flow regulator make of this pump a remarkable product. The coil is made of self-extinguishing material with a class H insulation winding. All the models are equipped with a noise suppression device which allows the pump to be installed in all those applications where low noise is a premium.

Shock absorbing supports are available for the quietest operation.

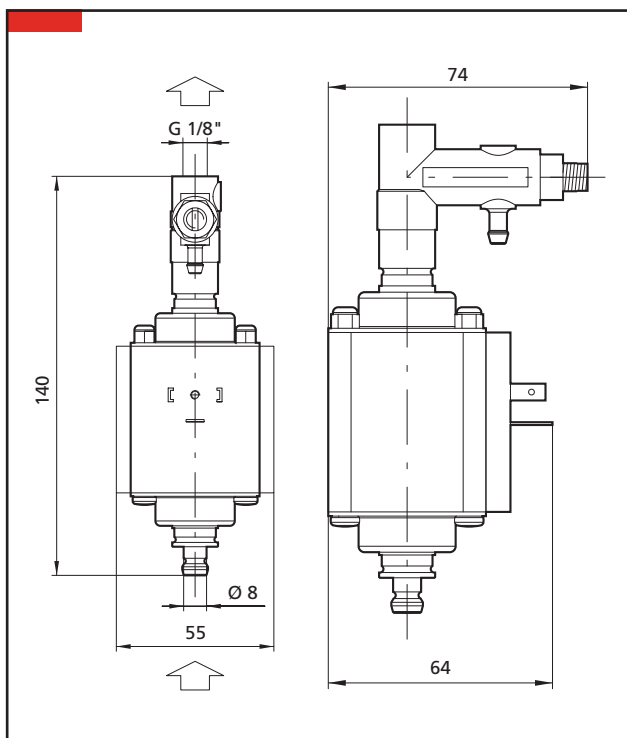

Electrical characteristics		
	"IF" Coil (IF) File E164244	"IL" Coil
Voltage	120 V	230 V
Frequency	60 Hz	50 Hz
Power	70 W	70 W
Current	0,98 A	0,65 A

Hydraulic characteristics	
• Self-priming	
• Max viscosity: 400 Cst	
• pH range: 6-8	
• Max liquid temperature: 50 °C (122 °F)	
• No dry running allowed	

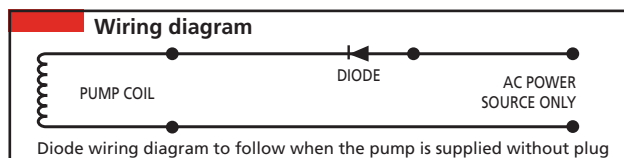

"IF" Coil is UL listed for 5' ON - 30" OFF without thermal protector

Fluid-o-Tech "Syrup" oscillating piston pumps

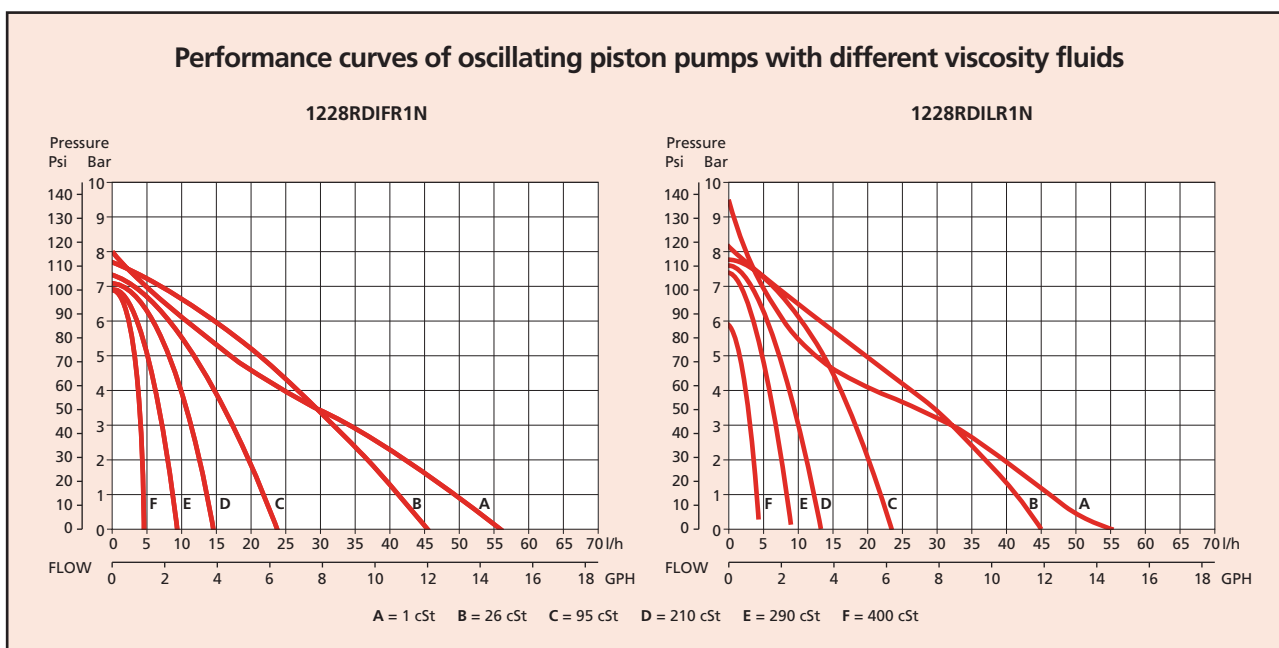
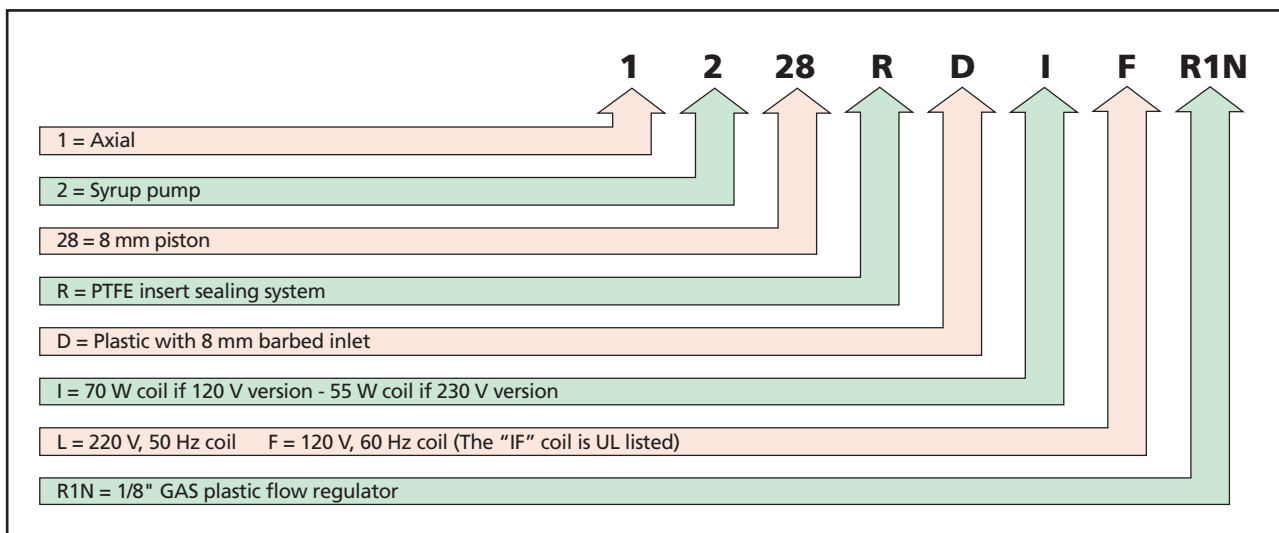

Figures of flow are averages
 Performance curves at 20 °C

VIP – SYRUP 01/03 Ed.



Fluid-o-Tech
<http://www.fluidotech.it>

Via Morimondo, 23
 20143 Milano - Italy
 Tel. (39) (02) 8917071
 Fax (39) (02) 89170799

161 Atwater St.,
 Plantsville CT (USA) 06479
 Tel. (1) (860) 276-9270
 Fax (1) (860) 620-0193

6F, 2-19-2, Akasaka,
 Minato-ku, Tokyo 107-0052 Japan
 Tel. (81) (0) 3-3585-8471
 Fax (81) (0) 3-3585-8472