

FLOWSERVE

Pump Division



MSX
Solids-Handling,
Submersible
Pumps

Pump Supplier To The World

Flowserve is the driving force in the global industrial pump marketplace. No other pump company in the world has the depth or breadth of expertise in the successful application of pre-engineered, engineered and special purpose pumps and systems.

Pumping Solutions

Flowserve is providing pumping solutions which permit customers to continuously improve productivity, profitability and pumping system reliability.

Market Focused Customer Support

Product and industry specialists develop effective proposals and solutions directed toward market and customer preferences. They offer technical advice and assistance throughout each stage of the product life cycle, beginning with the inquiry.



Dynamic Technologies

Flowserve is without peer in the development and application of pump technology, including:

- Hydraulic engineering
- Mechanical design
- Materials science
- Intelligent pumping
- Manufacturing technology

Broad Product Lines

Flowserve offers a wide range of complementary pump types, from pre-engineered process pumps, to highly engineered and special purpose pumps and systems. Pumps are built to recognized global standards and customer specifications.

Pump designs include:

- Single stage process
- Between bearing single stage
- Between bearing multistage
- Vertical
- Submersible motor
- Rotary
- Reciprocating
- Nuclear
- Specialty

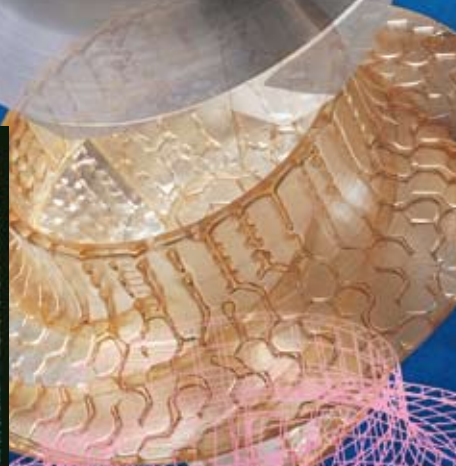
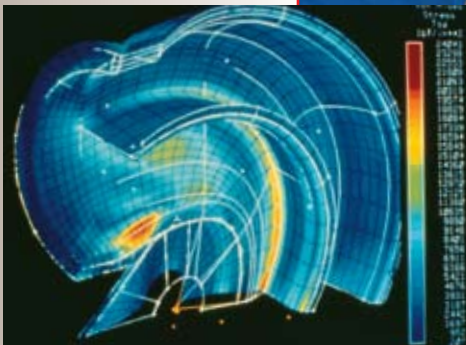

**MSX
Solids-Handling,
Submersible
Pumps**

Rugged and Reliable

The Flowserve MSX family of solids-handling, submersible pumps is engineered to perform efficiently in the most challenging environments, from pumping raw sewage to moving industrial wastewater and solids laden liquids.

**Operating and
Cost Saving Benefits**

MSX non-clog pumps reduce operating costs while providing long-life operation with minimal downtime.

- High efficiency
 - Superior hydraulic capability
 - Outstanding wire-to-water efficiency
 - EPACT rated high performance motors
 - Complete hydraulic and motor coverage
- Solid reliability
 - Long-lasting seal and bearing designs
 - Closed-loop cooling system for improved heat transfer
 - Spike-resistant windings for extended motor life
 - High-quality materials of construction

Broad Application

- Raw sewage
- Return-activated sludge
- Waste-activated sludge
- Mixed liquor
- Final effluent
- Filter backwash
- Dewatering
- Industrial process
- Industrial waste collection
- Flood protection

**Complementary
Pump Designs**

Depending upon application requirements, Flowserve can also provide these pump designs:

- End-suction, side-discharge, mixed-flow, non-clog pumps
- Vertical, wet-pit pumps

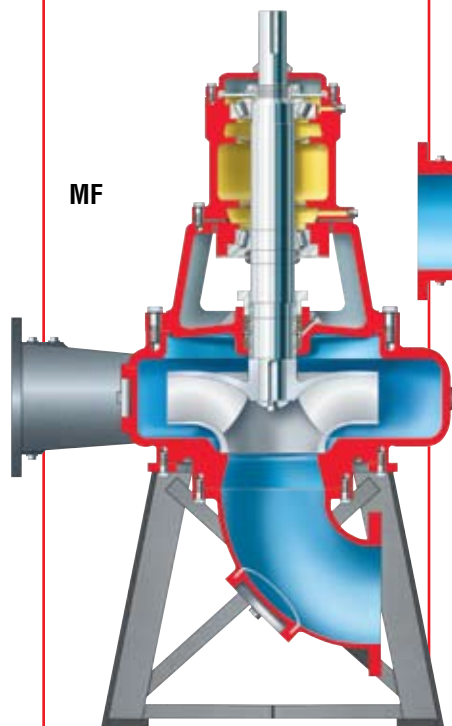

MN

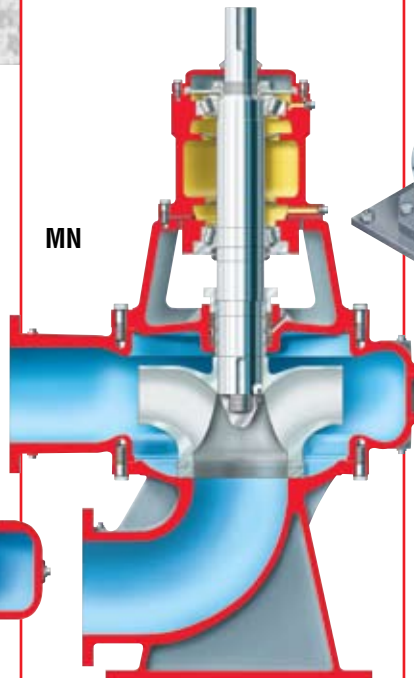

MVX

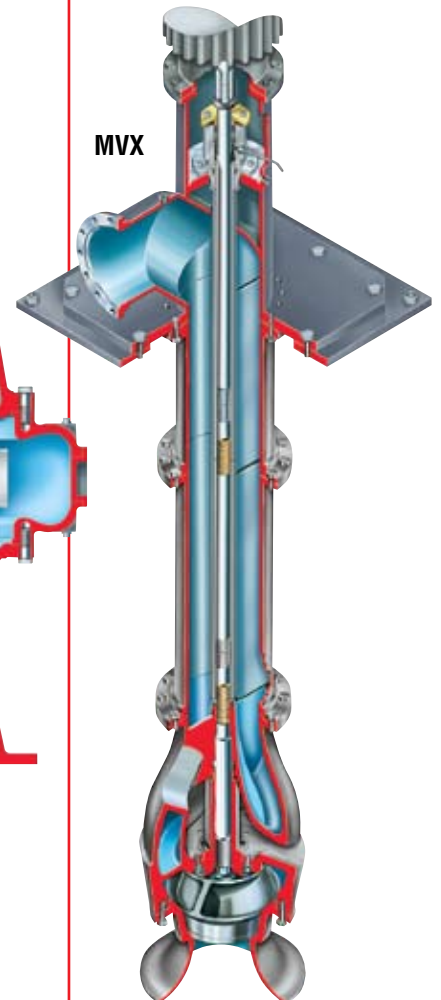

MSX Solids-Handling, Submersible Pumps

Flowserve MSX pumps are expressly designed to handle sewage and wastes of almost every form and description including both solids in solution and solids in suspension. Absolute reliability is the most critical requirement for these pumps. MSX-Series 1 medium-capacity and MSX-Series 2/3 high-capacity pumps provide that assurance along with long life, cost-efficient performance.

Operating Parameters

- Flows to 4545 m³/h (20 000 gpm)
- Heads to 90 m (300 ft)
- Sizes 80 mm (3 in) to 500 mm (20 in)
- Motors to 300 kW (400 hp)
 - FM approved version available for explosion-proof service
 - Variable-speed drives available

Industries Served

- Water resources
- Mining
- Agriculture
- General industry

Accessories

- Control panels
- Lifting chains
- Access covers
- Guide rail assemblies
- Level control floats
- Telemetry devices
- Valves

MSX-Series 1 Design Features

Solids-Handling Size to 80 mm (3 in) spherical

EPACT Rated Motor* offers high-efficiency performance for impressive energy savings

Shaft and Rotor are dynamically balanced for reduced vibration to assure smooth operation and long service life

Class H Rated Insulation System significantly extends motor life

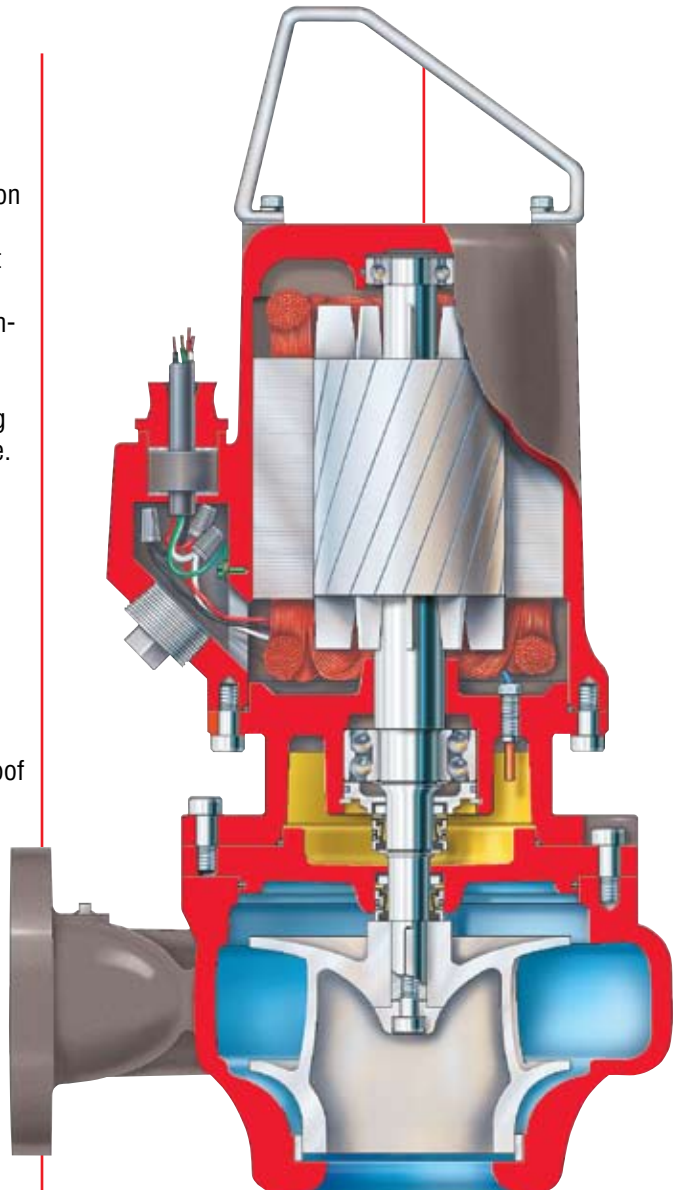

Watertight Cable Entry protects motor from moisture and contamination, thus extending its operating life

Impeller Wear Ring in stainless steel available as an option for extended impeller life

Spike-Resistant Windings are standard. In addition to smooth, consistent motor performance, this feature permits the handling of voltage spikes with variable frequency drive motor option

Long-Life, Angular Contact Bearings support axial and radial thrust loads for superior bearing and seal life

Sealing Fluid is environmentally friendly to eliminate media contamination concerns

Silicon Carbide Seal Faces in the lower mechanical seals provide durability and reliability. Upper mechanical seal faces are carbon/ceramic

High-Efficiency Hydraulics reduce energy consumption and operating cost while providing constant, predictable pumping performance

Extensive Hydraulic Coverage is achieved with discharge sizes of 80 mm (3 in) through 150 mm (6 in)

Higher Overall Wire-to-Water Efficiencies

* First motor to meet U.S. Energy Policy Act's (EPACT) efficiency regulations

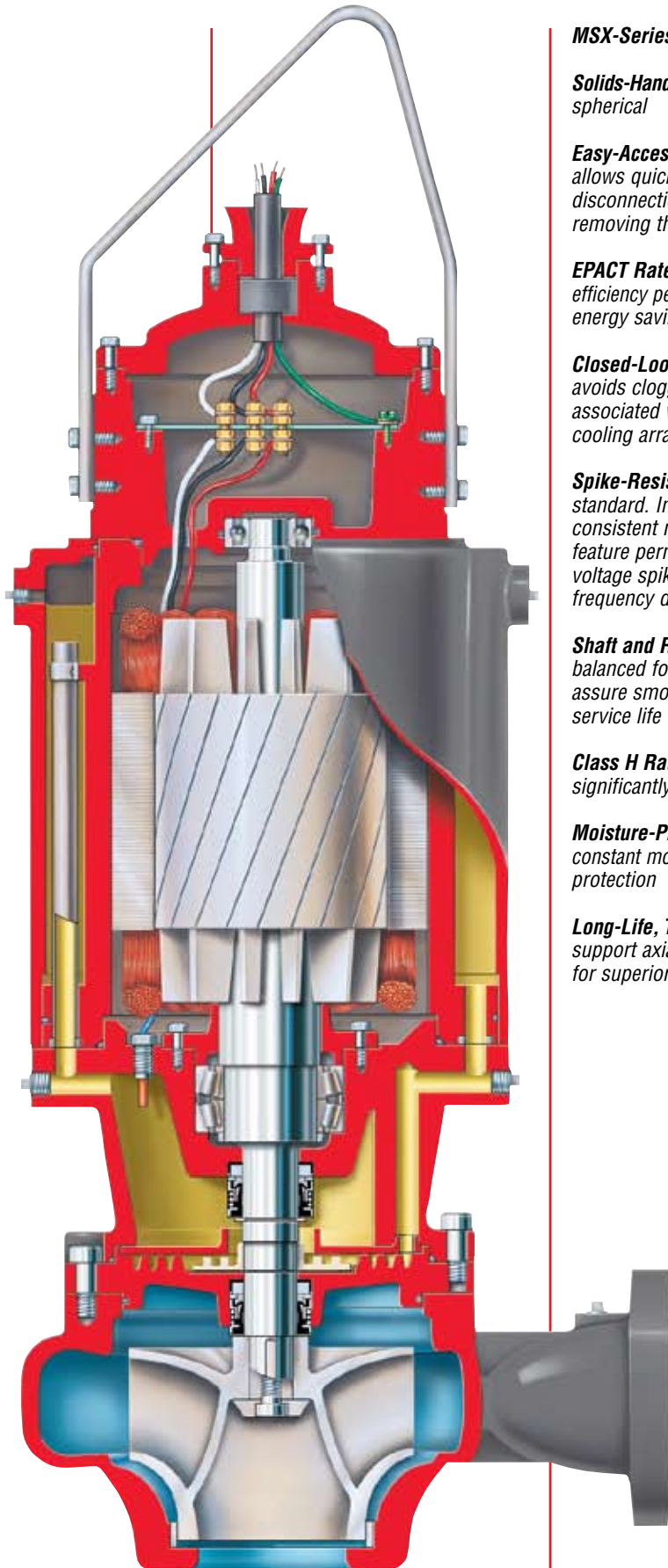

MSX-Series 2/3 Design Features

Solids-Handling Size to 80 mm (3 in) spherical

Easy-Access Terminal Chamber allows quick power connection-disconnection without entirely removing the pump from service

EPACT Rated Motor* offers high efficiency performance for impressive energy savings

Closed-Loop Cooling Design avoids clogging and hot spots associated with pumped media cooling arrangements

Spike-Resistant Windings are standard. In addition to smooth, consistent motor performance, this feature permits the handling of voltage spikes with variable frequency drive motor option

Shaft and Rotor are dynamically balanced for reduced vibration to assure smooth operation and long service life

Class H Rated Insulation System significantly extends motor life

Moisture-Protection Probe provides constant monitoring and motor protection

Long-Life, Tapered Roller Bearings support axial and radial thrust loads for superior bearing and seal life

Circulating Impeller in the cooling system effectively transfers heat to keep the motor running smoothly and to lubricate the upper mechanical seal faces

Sealing and Cooling Oil are environmentally friendly to eliminate contamination concerns

Heat Exchanger in the closed loop cooling system provides additional motor cooling protection

Impeller Wear Ring supplied in hardened stainless steel as a standard for extended impeller life

Silicon Carbide Seal Faces in the lower mechanical seals provide durability and reliability. Upper mechanical seal faces are carbon/ceramic

High-Efficiency Hydraulics reduce energy consumption and operating costs while providing constant, predictable pumping efficiency

High Overall Wire-to-Water Efficiencies

* First motor to meet U.S. Energy Policy Act's (EPACT) efficiency regulations

**Technical Data
and Options**

Wet-Pit Mounting Option

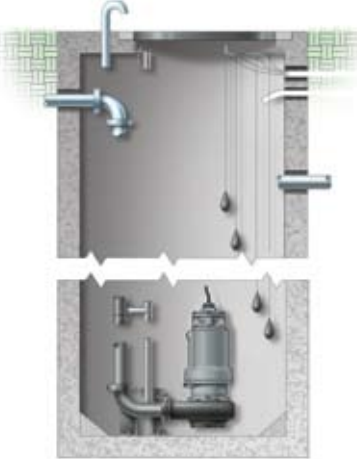

Dry-Pit Mounting Option



Transportable-Style Option



Complementary Equipment

- Controls
- Level switches
- Valves
- Access covers
- Hoists
- Testing

Component	Standard Materials
Pump Casing	Cast Iron, ASTM A48, CL30
Casing Wear Ring	Cast Iron, ASTM A48, CL30
Impeller	Cast Iron, ASTM A48, CL30
Impeller Wear Ring	Hardened SS - 8 in -14 in Discharge
Motor Housing	Cast Iron, ASTM A48, CL30
Cooling Jacket	Cast Iron, ASTM A48, CL30
Seal Plate	Cast Iron, ASTM A48, CL30
Bearing Plate	Cast Iron, ASTM A48, CL30
Cable Entry	Cast Iron, ASTM A48, CL30
Hardware	Type 316 SS
Shaft	Type 416 SS
O-Rings	Buna-N
Cable Entry Grommet	Neoprene
Seal Oil	Environmentally friendly
Exterior Coatings	Corrosion resistant paint
Impeller Key/Bolt	Type 416 SS/Type 316 SS

MSX Range Chart

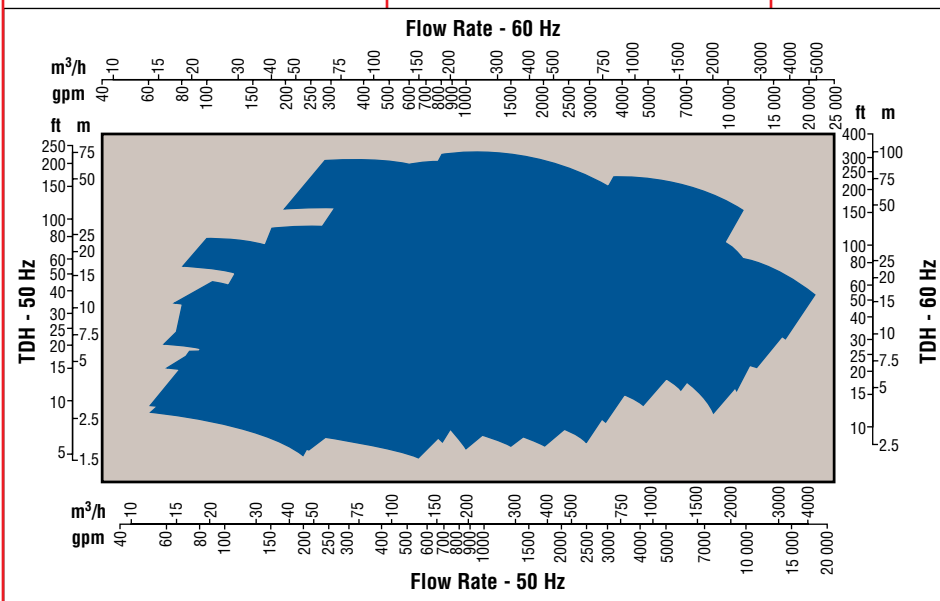

Global Engineered Services and Support

- Total Cost Reduction*
- Asset Management*
- Product Life Cycle*
- Performance Re-rates*
- Site Diagnostics*
- Repair Services*
- Energy Management*
- Spare Parts*
- Maintenance Contracts*
- Materials Upgrades*
- Turnkey Services*
- Field Repairs*
- Installation*
- Project Supervision*
- Commissioning*
- Equipment Upgrades*
- Condition Monitoring*
- Systems Analysis*
- Field Machining*

Service Dedication

Flowserve Engineered Services is focused on providing customers with uncompromising service and support, where and when needed. Engineered Services is dedicated to delivering the highest quality support by integrating its extensive pump and materials engineering knowledge with creative service solutions. Engineered Services prides itself in understanding the business challenges facing customers and is prepared to manage solutions to succeed as a team.

A worldwide network of service and repair centers staffed by highly skilled engineers and technicians is available around the clock, seven days a week to respond to customer queries, to evaluate and troubleshoot problems and to provide reliable solutions.

Strength of Experience, Commitment to Excellence

Flowserve has long served industries requiring superior equipment performance and service life.

- Oil and gas production
- Hydrocarbon processing
- Chemical processing
- Water resources
- Power generation
- Nuclear
- Mining and mineral processing
- Pulp and paper
- General industry

Engineered Services is dedicated to maximizing equipment performance and providing reliability-centered maintenance programs for pumps and related equipment, regardless of manufacturer. Using the FlowStar™ asset management software, Engineered Services tracks performance and supports improvement programs using a service life cycle cost business approach. The results are improved reliability and increased profitability.

Your Business Partner

Flowserve partners with customers to respond to the dynamic business conditions that affect them. Flowserve will work with customers to drive efficiency, maximize throughput and control process quality. Whether your needs involve on-site technical assistance or broader project planning with full turnkey responsibility, you can rely on the strength of Flowserve Engineered Services to deliver professional, reliable results.

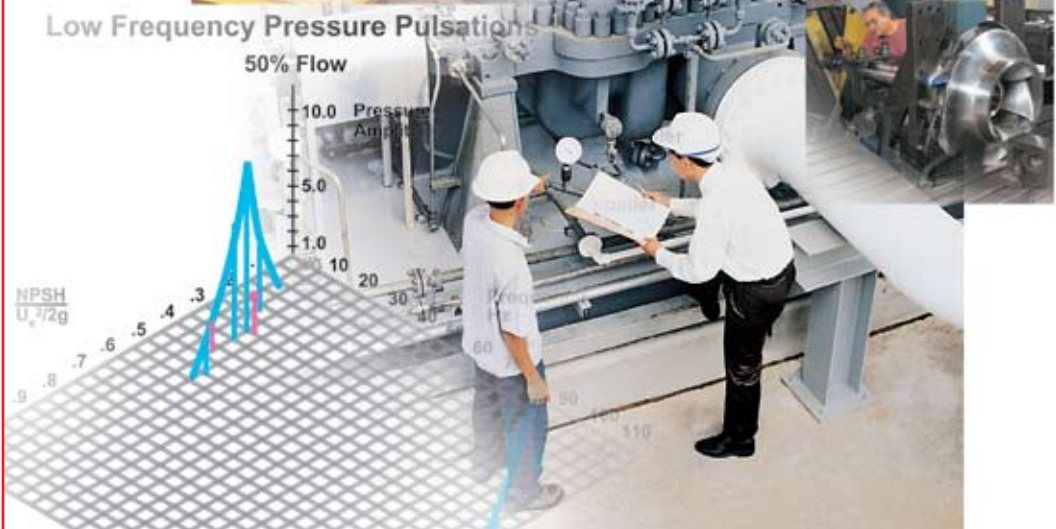

**Flowserve... Supporting Our Customers
With The World's Leading
Pump Brands**



USA and Canada

Flowserve Corporation
5215 North O'Connor Blvd.
Suite 2300
Irving, Texas 75039-5421 USA
Telephone: 1 937 890 5839

Europe, Middle East, Africa

Flowserve Corporation
Gebouw Hagepoint
Westbroek 39-51
4822 ZX Breda
Netherlands
Telephone: 31 76 502 8920



Pump Division

Latin America

Flowserve Corporation
Boulevard del Cafetal
Edificio Ninina, Local 7
El Cafetal - Caracas
Venezuela 1061
Telephone: 58 212 985 3092
Telefax: 58 212 985 1007

Asia Pacific

Flowserve Pte. Ltd.
10 Tuas Loop
Singapore 637345
Telephone: 65 6771 0600
Telefax: 65 6779 4607

Your local Flowserve representative:

**To find your local Flowserve representative
please use the Sales Support Locator System
found at www.flowserve.com**

Or call toll free: 1 800 728 PUMP (7867)