



Pumps



ESP2

***Vertical
Immersion
Sump Pump***

Bulletin PS-10-24c (E)

Bulletin PS-10-24c (E/A4)

Pump Supplier To The World

Flowserve is the driving force in the global industrial pump marketplace. No other pump company in the world has the depth or breadth of expertise in the successful application of pre-engineered, engineered and special purpose pumps and systems.

Pumping Solutions

Flowserve is providing pumping solutions which permit customers to continuously improve productivity, profitability and pumping system reliability.

Market Focused Customer Support

Product and industry specialists develop effective proposals and solutions directed toward market and customer preferences. They offer technical advice and assistance throughout each stage of the product life cycle, beginning with the inquiry.



Dynamic Technologies

Flowserve is without peer in the development and application of pump technology, including:

- Hydraulic engineering
- Mechanical design
- Materials science
- Intelligent pumping
- Manufacturing technology

Broad Product Lines

Flowserve offers a wide range of complementary pump types, from pre-engineered process pumps, to highly engineered and special purpose pumps and systems. Pumps are built to recognized global standards and customer specifications. Pump designs include:

- Single stage process
- Between bearing single stage
- Between bearing multistage
- Vertical
- Submersible motor
- Rotary
- Reciprocating
- Nuclear
- Specialty

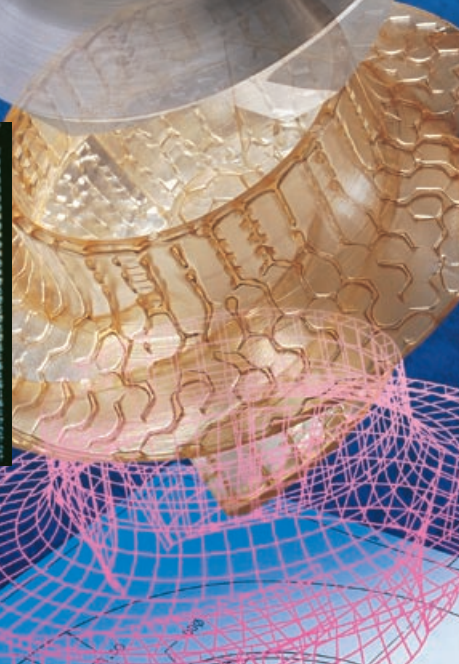
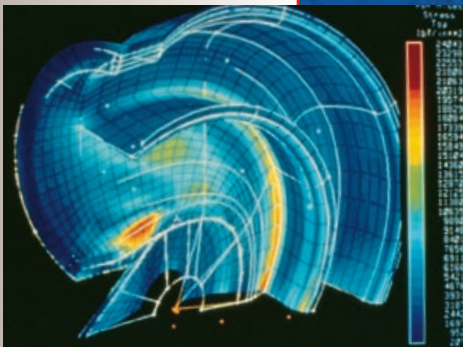

ESP2
Vertical
Immersion
Sump Pump

Versatile, Reliable Performer
The ESP2 is an industrial vertical wet-pit immersion sump pump developed specifically to handle waste liquids, effluents and liquid transfers. This rugged, single stage pump is designed to perform tough jobs reliably, under a variety of difficult conditions.

The ESP2 incorporates many proven features to increase efficiency and ease of operation.

- Industry standard “TCV” motors
- Double row external thrust bearing
- Extended grease lube fitting
- Optimized lineshaft-shaft bearing design
- Premium carbon graphite bearings
- Lineshaft bearing lubrication manifold
- Large basket strainer
- Flanged discharge
- Available simplex and duplex mounting arrangements with sealing variations

Applications

- Wet pit
- Effluent
- Water treatment
- Liquid transfer
- Hydrocarbon processing
- Chemical processing
- General industry

Complementary Pump Designs

- Mark 3 ASME (ANSI) chemical process pump
- CPX ISO chemical process pump
- VGRP non-metallic vertical sump pump
- VTP vertical turbine pump
- VPC double case vertical turbine pump
- RJ rubber-lined vertical lineshaft pump
- MJ hard metal vertical lineshaft pump
- FRBHV vertical cantilever sump pump

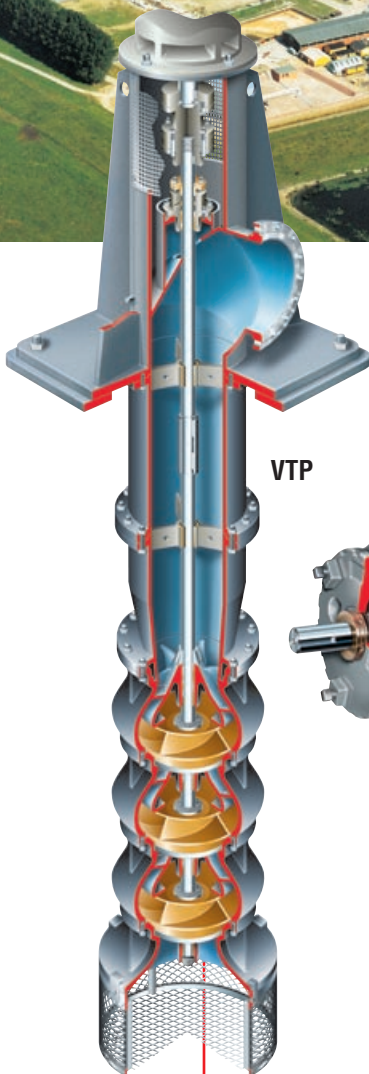

VTP

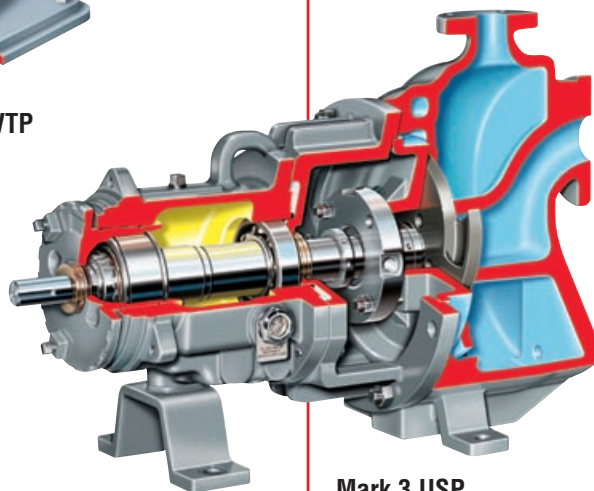

Mark 3 USP

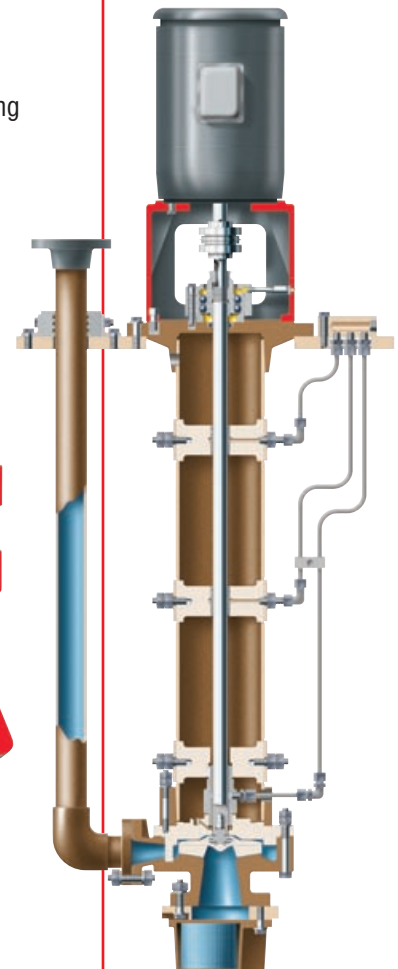

VGRP

ESP2
Vertical
Immersion
Sump Pump

The Flowserve ESP2 vertical immersion sump pump delivers extended pump life over a wide range of applications and in pit depths to 6 m (20 ft). A proven performer in chemical and hydrocarbon processing, the ESP2 is available in many corrosion resistant materials and with a broad range of options to suit most requirements.

Available in both simplex and duplex mounting arrangements, the ESP2 accommodates multiple sealing arrangements. This allows customers to tailor the pump to site-specific requirements.

Casing Design incorporates a fully confined gasket to ensure proper sealing. Available in a wide range of materials to suit application requirements

One-Piece, Heavy-Duty Shaft is ground to a high finish and designed, along with the bearing sizes and spacing, to produce the highest critical speeds available

Hydraulically Balanced Semi-Open Impeller is externally adjustable and anti-rotation threaded. O-ring sealed, the precision cast impeller is available in a wide range of materials to suit application requirements

Radial and Thrust Bearings are located in the driver. Double row thrust bearings are mounted externally and sized to handle all pump axial thrust

Bearings are closely spaced to eliminate shaft whip. Materials range from low cost bronze to PTFE and fluted rubber to suit application requirements

T.B. Woods Spacer Type S Couplings are precision machined and self-aligning

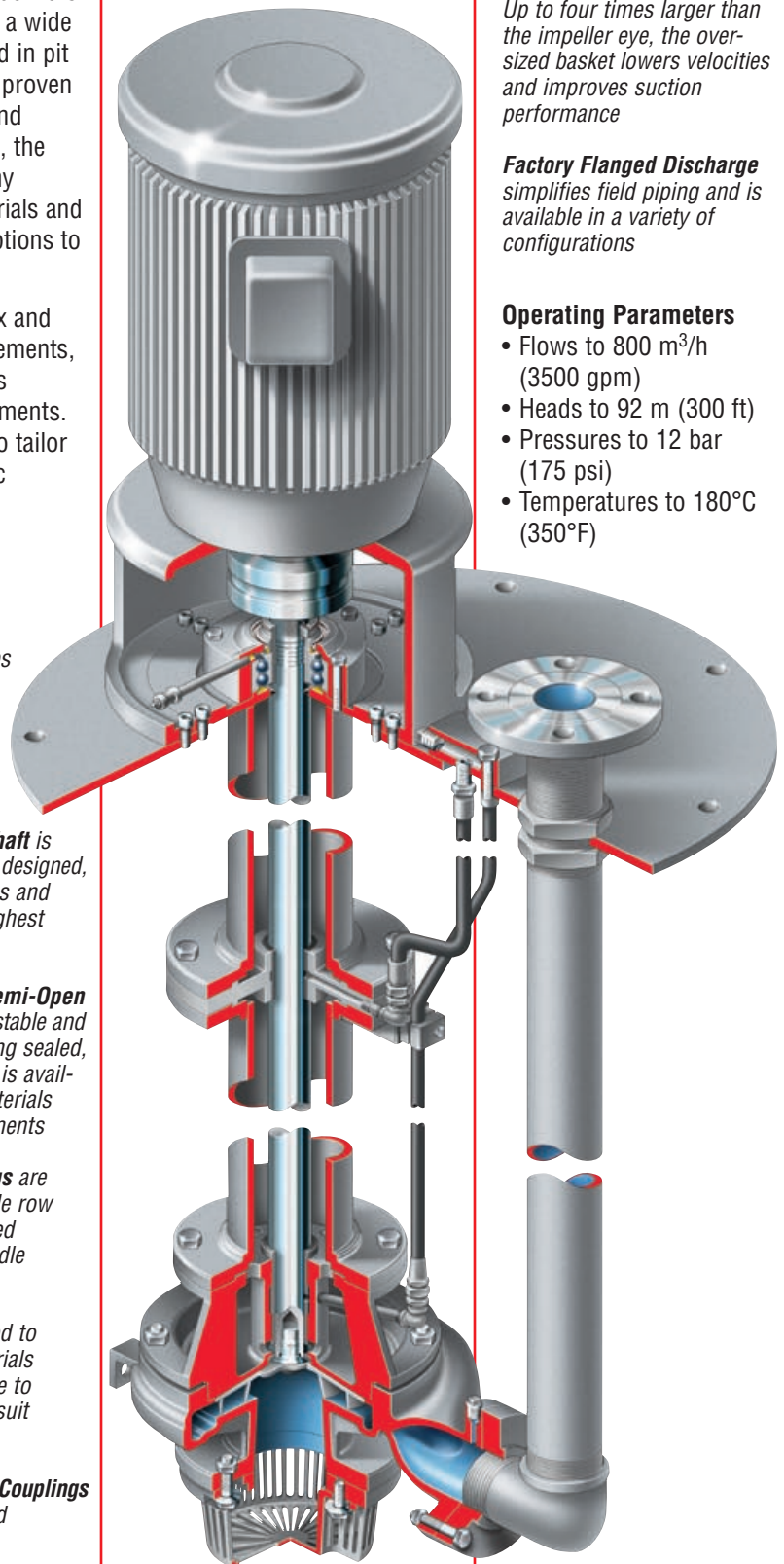

Large Polypropylene Basket Strainer resists corrosion. Up to four times larger than the impeller eye, the oversized basket lowers velocities and improves suction performance

Factory Flanged Discharge simplifies field piping and is available in a variety of configurations

- Operating Parameters**
- Flows to 800 m³/h (3500 gpm)
 - Heads to 92 m (300 ft)
 - Pressures to 12 bar (175 psi)
 - Temperatures to 180°C (350°F)



Lowered Maintenance Costs

The ESP2 incorporates many features designed to reduce maintenance costs.

- Lineshaft bearing lubrication manifold connects to an external clean lube source with multiple lube lines terminating in one unit
- Extended grease lube fitting simplifies lubrication by eliminating guard removal
- TCV motor allows for quick, accurate alignment
- Premium carbon graphite bearings are metal-backed for ease of installation

Reliability Enhancing Features

- Premium carbon graphite bearings increase shaft stability, extending mean time between planned maintenance (MTBPM)
- API 610 compliant lineshaft-shaft bearing design virtually eliminates shaft failure and increases MTBPM
- Double row external thrust bearing eliminates transmission of pump developed loads to the motor, preventing costly motor bearing failures

Simplex or Duplex Mounting Arrangements permit site-specific customization.

Lubrication Options

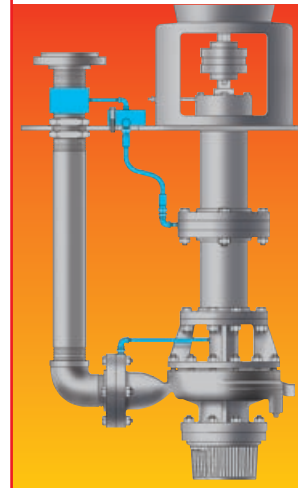

Product Lubrication is available for clean liquids.

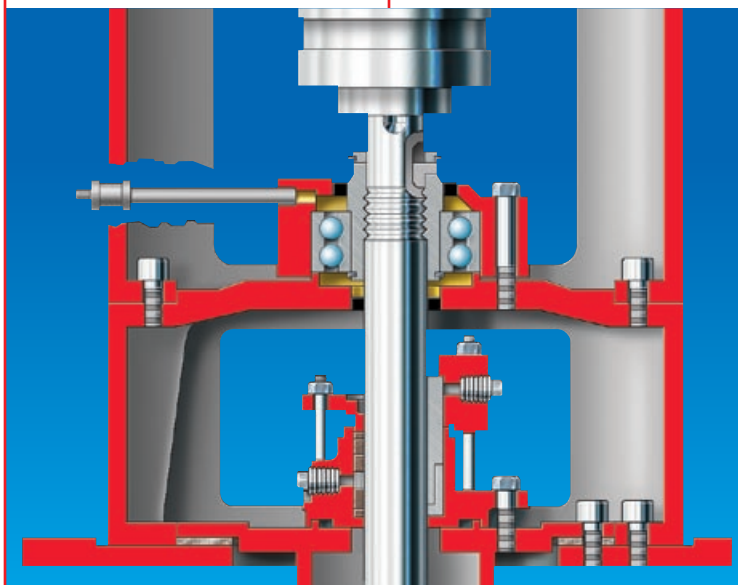

Standard Double Row External Thrust Bearing eliminates pump-developed loads from being transmitted to the motor.

Optional Upper Stuffing Box prevents vapors from escaping to the atmosphere and can be used with soft packing or mechanical seal.

Available Bearing Materials

- Carbon graphite
- Bronze
- Cast iron
- Rubber
- Fluoropolymer
- Fluoroelastomer

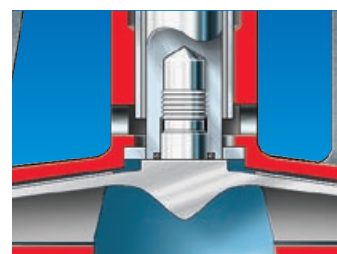

Replaceable Sealing Ring provides means of restoring original tolerance between shaft and adapter. Also provides easy means for bearing removal.



Grease Lubrication is available for applications in which the pumped product possesses poor lubricity or contains solids.

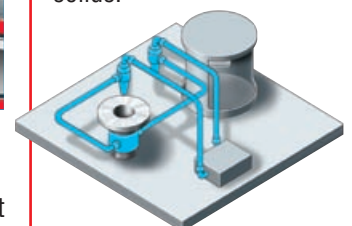

Dual Particle Separator is available for applications requiring the removal of small amounts of solids.

Options and Technical Data

Customizable Liquid Level Controls and Monitors, ranging from on-off mechanically actuated to multi-pump displacer type, are available.

Suction Tailpipes can be provided for sump depths greater than the maximum pump length or where it is desirable to reduce the pump length.

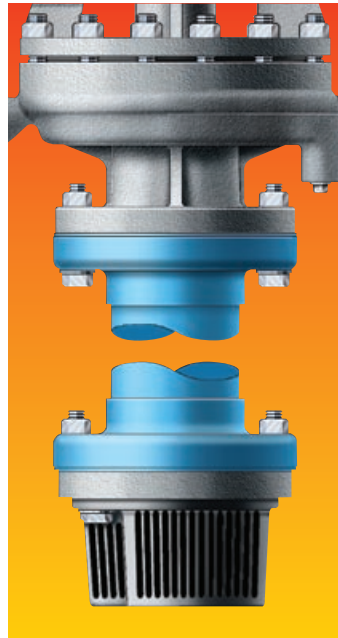

Mounting Plate Options

Pressurized mounting plate withstands 3.4 bar (50 psi) differential. Available with standard or gas-type mechanical seals.

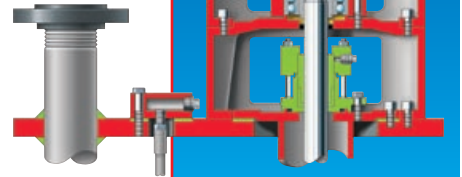

Vapor Proof mounting plate withstands 0.34 bar (5 psi) differential pressure. Available packed or mechanically sealed.

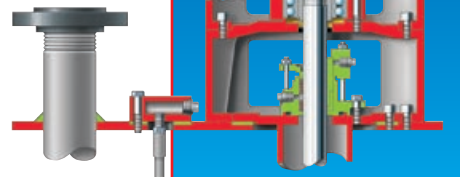

Vapor Tight mounting plate uses a standard lip seal.

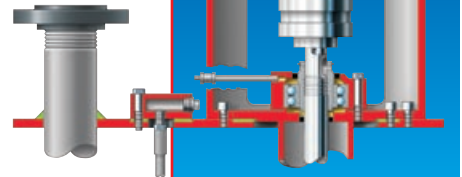

ESP2 Range Chart

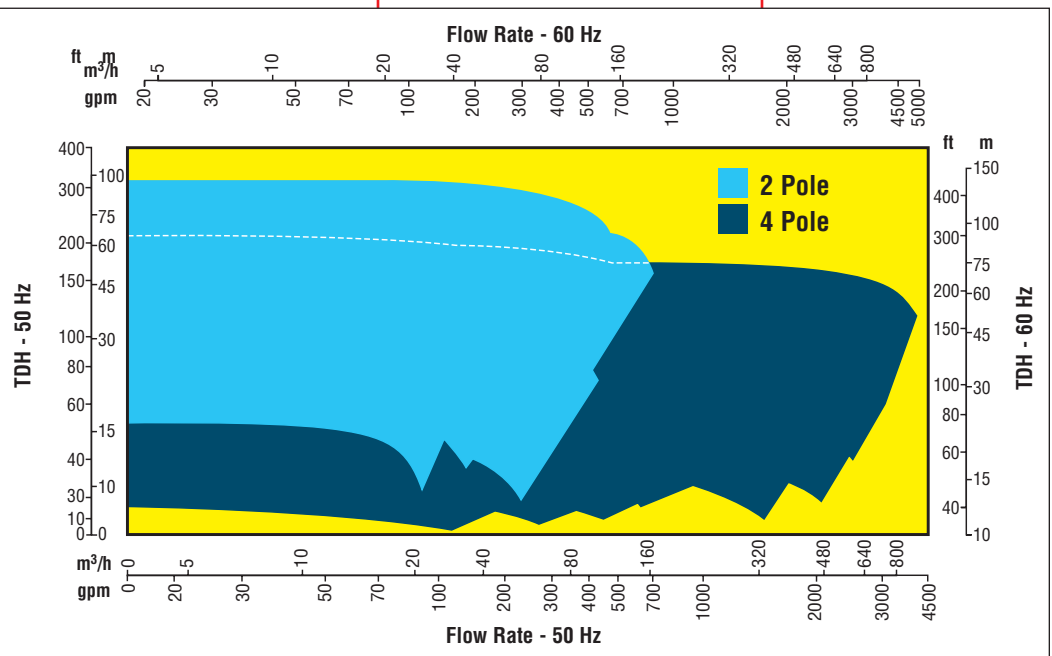

Global Engineered Services and Support

- Total Cost Reduction*
- Asset Management*
- Product Life Cycle*
- Performance Re-rates*
- Site Diagnostics*
- Repair Services*
- Energy Management*
- Spare Parts*
- Maintenance Contracts*
- Materials Upgrades*
- Turnkey Services*
- Field Repairs*
- Installation*
- Project Supervision*
- Commissioning*
- Equipment Upgrades*
- Condition Monitoring*
- Systems Analysis*
- Field Machining*

Service Dedication

Flowserve Engineered Services is focused on providing customers with uncompromising service and support, where and when needed. Dedicated to delivering the highest quality support, Engineered Services integrates its extensive pump and materials engineering knowledge with creative service solutions. Engineered Services fully understands the business challenges facing customers and is prepared to manage solutions to succeed as a team.

A worldwide network of service and repair centers staffed by highly skilled engineers and technicians is available around the clock, seven days a week to respond to customer queries, to evaluate and troubleshoot problems and to provide reliable solutions.



Strength of Experience, Commitment to Excellence

Flowserve has long served industries requiring superior equipment performance and service life.

- Oil and gas production
- Hydrocarbon processing
- Chemical processing
- Water resources
- Power generation
- Nuclear
- Mining and mineral processing
- Pulp and paper
- General industry

Engineered Services is dedicated to maximizing equipment performance and providing reliability-centered maintenance programs for pumps and related equipment, regardless of manufacturer. Using the FlowStar™ asset management software, Engineered Services tracks performance and supports improvement programs using a service life cycle cost business approach. The results are improved reliability and increased profitability.

Business Partner

Flowserve partners with customers to respond to the dynamic business conditions that affect them. Flowserve will work with customers to drive efficiency, maximize throughput and control process quality. Whether user needs involve on-site technical assistance or broader project planning with full turnkey responsibility, Flowserve Engineered Services will deliver professional, reliable results.

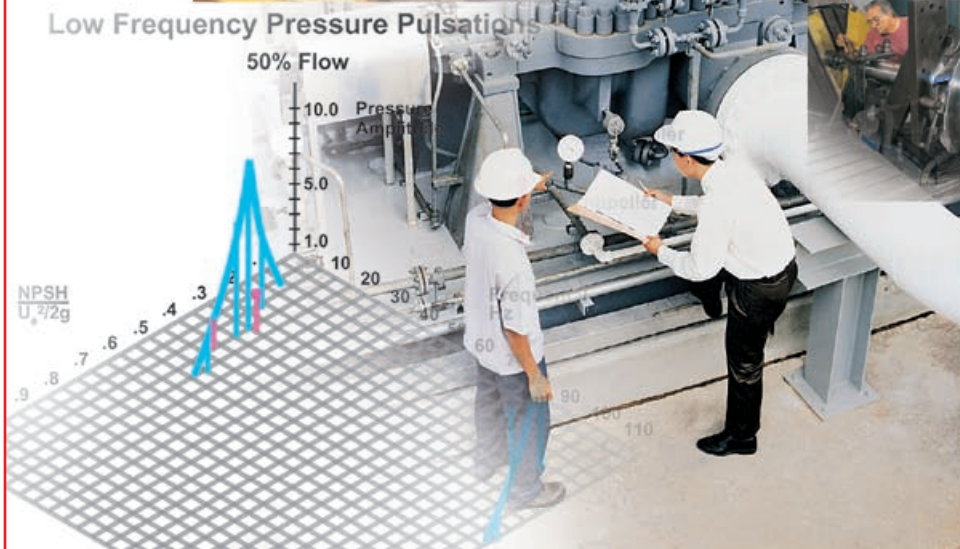

**Flowserve... Supporting Our Customers
With The World's Leading
Pump Brands**



USA and Canada

Flowserve Corporation
5215 North O'Connor Blvd.
Suite 2300
Irving, Texas 75039-5421 USA
Telephone: 1 937 890 5839

Europe, Middle East, Africa

Flowserve Corporation
Gebouw Hagepoint
Westbroek 39-51
4822 ZX Breda
Netherlands
Telephone: 31 76 502 8920



Your local Flowserve representative:

**To find your local Flowserve representative
please use the Sales Support Locator System
found at www.flowserve.com**

Or call toll free: 1 800 728 PUMP (7867)

Latin America

Flowserve Corporation
Boulevard del Cafetal
Edificio Ninina, Local 7
El Cafetal - Caracas
Venezuela 1061
Telephone: 58 212 985 3092
Telefax: 58 212 985 1007

Asia Pacific

Flowserve Pte. Ltd.
200 Pandan Loop #06-03/04
Pantech 21
Singapore 128388
Telephone: 65 6775 3003
Telefax: 65 6779 4607