

CIRCULATORS

FOR HEATING AND AIR CONDITIONING SYSTEMS

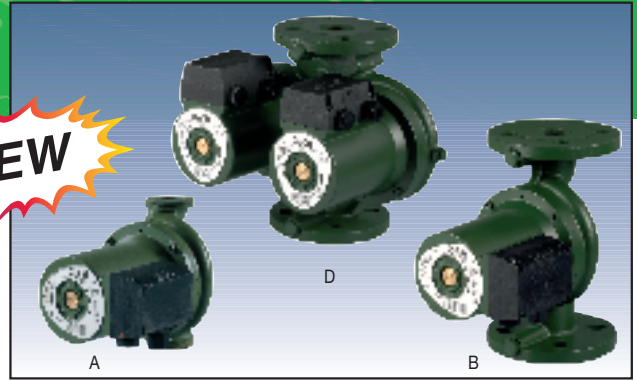

Pump body in cast iron and motor casing in die-cast aluminium. Technopolymer impeller and tempered stainless steel driving shaft mounted on graphite brushings lubricated by the pumped liquid itself. Flanged vents, (threaded series A), provided with threaded connectors for controlling gauges. Stainless steel protective rotor sleeve, stator sleeve and closing flange. Ceramic thrust bearing, E.P.D.M. "O" rings and brass air outlet cap. The two-pole asynchronous motor with wet rotors designed for **three-speed** operation, single-phase version, for **two-speed** operation, for three-phase version. Thermal overload protection incorporated in the single phase version. In the twin version an automatic clapet type valve and blank flange are provided.

Operating range: from 1 to 12 m³/h with head up to 8 metres.

Liquid temperature range: from -10°C to +110°C.

Pumped liquid characteristics: clean, free from solids and mineral oils, not viscous, chemically neutral, close to the characteristics of water (max 30% glycol).

Maximum working pressure: 10 bar (1000 kPa).

Protection level: IP 44

Insulation class: F

Cable grommet: PG 11

Installation: with motor axis horizontal.

MODEL	VOLTAGE 50Hz	CENTRE DISTANCE mm	UNIONS ON REQUEST	SPEED	ELECTRICAL DATA					MINIMUM HEAD PRESSURE
					N r.p.m.	P1 MAX W	In A	CAPACITOR		
								μF	Vc	
A 50/180 XM	1x230 V ~	180	2"G	3	2791	184	0,92	4	400	t° +90°C m.c.a. 1,5
				2	2651	189	0,92			
				1	2297	168	0,80			
A 50/180 M	1x230 V ~	180	1 1/2"G	3	2766	195	0,95	4	400	t° +90°C m.c.a. 1,5
				2	2616	194	0,95			
				1	2215	180	0,85			
A 50/180 XT	3x400 V ~	180	2"G	2	2838	201	0,50	-	-	t° +90°C m.c.a. 1,5
				1	2520	129	0,23			
				2	2827	197	0,52			
A 50/180 T	3x400 V ~	180	1 1/2"G	2	2502	139	0,25	-	-	t° +90°C m.c.a. 1,5
				1	2297	168	0,80			
				3	2658	271	1,18			
A 56/180 XM	1x230 V ~	180	2"G	2	2117	294	1,32	7	400	t° +90°C m.c.a. 1,5
				1	1394	224	1,00			
				3	2636	282	1,23			
A 56/180 M	1x230 V ~	180	1 1/2"G	2	2226	287	1,30	7	400	t° +90°C m.c.a. 1,5
				1	1485	228	1,06			
				3	2636	282	1,23			
A 56/180 XT	3x400 V ~	180	2"G	2	2708	291	0,60	-	-	t° +90°C m.c.a. 1,5
				1	2178	200	0,32			
				3	2683	256	1,12			
A 56/180 T	3x400 V ~	180	1 1/2"G	2	2704	297	0,60	-	-	t° +90°C m.c.a. 1,5
				1	2178	200	0,33			
				3	2674	264	1,15			
A 80/180 XM	1x230 V ~	180	2"G	2	2374	260	1,17	7	400	t° +90°C m.c.a. 2,5
				1	1688	218	1,00			
				3	2674	264	1,15			
A 80/180 M	1x230 V ~	180	1 1/2"G	2	2356	262	1,20	7	400	t° +90°C m.c.a. 2,5
				1	1615	223	1,00			
				3	2674	264	1,15			
A 80/180 XT	3x400 V ~	180	2"G	2	2727	272	0,57	-	-	t° +90°C m.c.a. 2,5
				1	2227	186	0,30			
				3	2746	410	1,77			
A 80/180 T	3x400 V ~	180	1 1/2"G	2	2724	271	0,57	-	-	t° +90°C m.c.a. 2,5
				1	2226	187	0,31			
				3	2746	410	1,77			
A 110/180 XM	1x230 V ~	180	2"G	2	2552	393	1,78	12	450	t° +90°C m.c.a. 2,5
				1	2052	361	1,64			
				3	2746	410	1,77			
A 110/180 XT	3x400 V ~	180	2"G	2	2759	403	0,90	-	-	t° +90°C m.c.a. 2,5
				1	2341	289	0,48			
				3	2746	410	1,77			

ELECTRICAL DATA

SINGLE WITH UNIONS

MODEL	VOLTAGE 50Hz	CENTRE DISTANCE mm	UNIONS ON REQUEST	SPEED	ELECTRICAL DATA					MINIMUM HEAD PRESSURE
					N r.p.m.	P1 MAX W	In A	CAPACITOR		
								μF	Vc	
B 50/250.40 M	1x230 V~	250	DN 40	3	2766	195	0,95	2,5	400	t° +90°C m.c.a. 1,5
				2	2616	194	0,95			
				1	2215	180	0,85			
B 50/250.40 T	3x400 V~	250	DN 40	2	2827	197	0,52	-	-	t° +90°C m.c.a. 1,5
				1	2502	139	0,25			
				3	2636	282	1,23			
B 56/250.40 M	1x230 V~	250	DN 40	2	2226	287	1,30	7	400	t° +90°C m.c.a. 1,5
				1	1485	228	1,06			
				3	2636	282	1,23			
B 56/250.40 T	3x400 V~	250	DN 40	2	2704	297	0,60	-	-	t° +90°C m.c.a. 1,5
				1	2178	200	0,33			
				3	2674	264	1,15			
B 80/250.40 M	1x230 V~	250	DN 40	2	2356	262	1,20	7	400	t° +90°C m.c.a. 2,5
				1	1615	223	1,00			
				3	2674	264	1,15			
B 80/250.40 T	3x400 V~	250	DN 40	2	2724	271	0,57	-	-	t° +90°C m.c.a. 2,5
				1	2226	187	0,31			
				3	2746	410	1,77			
B 110/250.40 M	1x230 V~	250	DN 40	2	2552	393	1,78	12	450	t° +90°C m.c.a. 2,5
				1	2052	361	1,64			
				3	2746	410	1,77			
B 110/250.40 T	3x400 V~	250	DN 40	2	2759	403	0,90	-	-	t° +90°C m.c.a. 2,5
				1	2341	289	0,48			
				3	2746	410	1,77			

SINGLE WITH FLANGES

MODEL	VOLTAGE 50Hz	CENTRE DISTANCE mm	UNIONS ON REQUEST	SPEED	ELECTRICAL DATA					MINIMUM HEAD PRESSURE
					N r.p.m.	P1 MAX W	In A	CAPACITOR		
								μF	Vc	
D 50/250.40 M	1x230 V~	250	DN 40 - PN 10	3	2766	195	0,95	2,5	400	t° +90°C m.c.a. 1,5
				2	2616	194	0,95			
				1	2215	180	0,85			
D 50/250.40 T	3x400 V~	250	DN 40 - PN 10	2	2827	197	0,52	-	-	t° +90°C m.c.a. 1,5
				1	2502	139	0,25			
				3	2636	282	1,23			
D 56/250.40 M	1x230 V~	250	DN 40 - PN 10	2	2226	287	1,30	7	400	t° +90°C m.c.a. 1,5
				1	1485	228	1,06			
				3	2636	282	1,23			
D 56/250.40 T	3x400 V~	250	DN 40 - PN 10	2	2704	297	0,60	-	-	t° +90°C m.c.a. 1,5
				1	2178	200	0,33			
				3	2674	264	1,15			
D 80/250.40 M	1x230 V~	250	DN 40 - PN 10	2	2356	262	1,20	7	400	t° +90°C m.c.a. 2,5
				1	1615	223	1,00			
				3	2674	264	1,15			
D 80/250.40 T	3x400 V~	250	DN 40 - PN 10	2	2724	271	0,57	-	-	t° +90°C m.c.a. 2,5
				1	2226	187	0,31			
				3	2746	410	1,77			
D 110/250.40 M	1x230 V~	250	DN 40 - PN 10	2	2552	393	1,78	12	450	t° +90°C m.c.a. 2,5
				1	2052	361	1,64			
				3	2746	410	1,77			
D 110/250.40 T	3x400 V~	250	DN 40 - PN 10	2	2759	403	0,90	-	-	t° +90°C m.c.a. 2,5
				1	2341	289	0,48			
				3	2746	410	1,77			

TWIN WITH FLANGES

HYDRAULIC DATA

A 50/180 XM

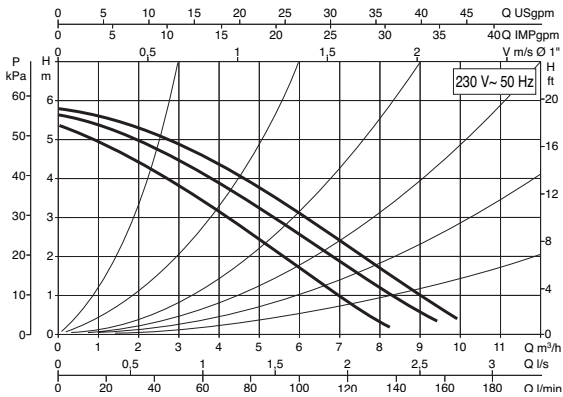

A 50/180M - B 50/250.40M - D 50/250.40M

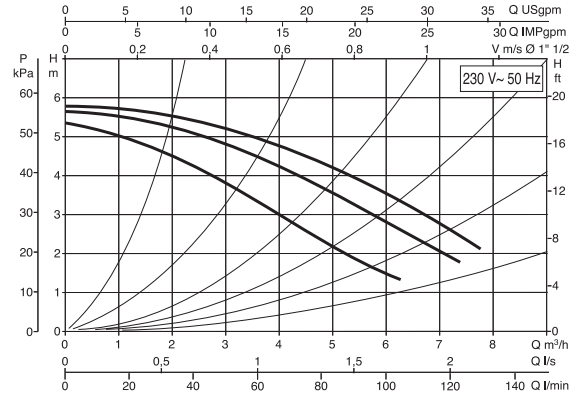

A 50/180 XT -

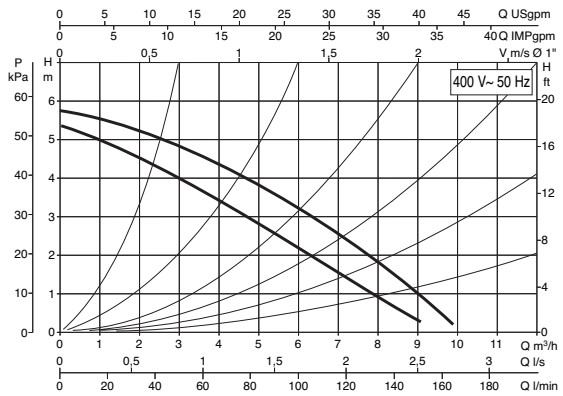

A 50/180 T - B 50/250.40T - D 50/250.40T

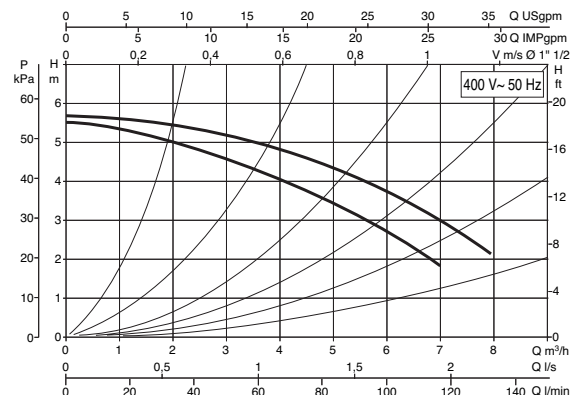

A 56/180 XM -

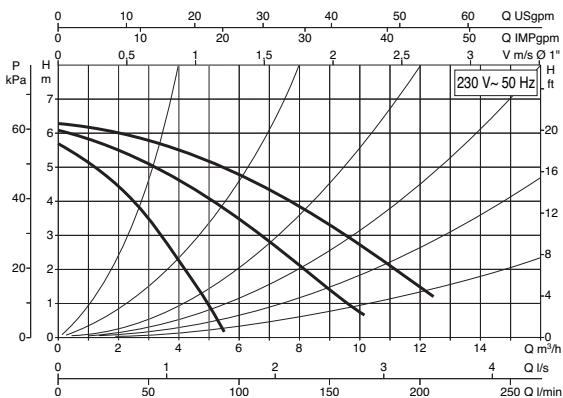

A 56/180 M - B 56/250.40M - D 56/250.40M

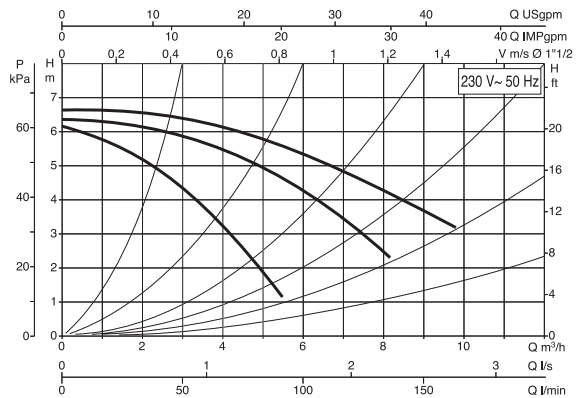

A 56/180 XT -

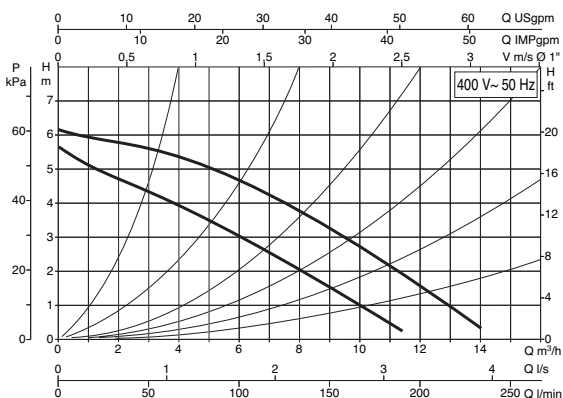

A 56/180 T - B 56/250.40T - D 56/250.40T

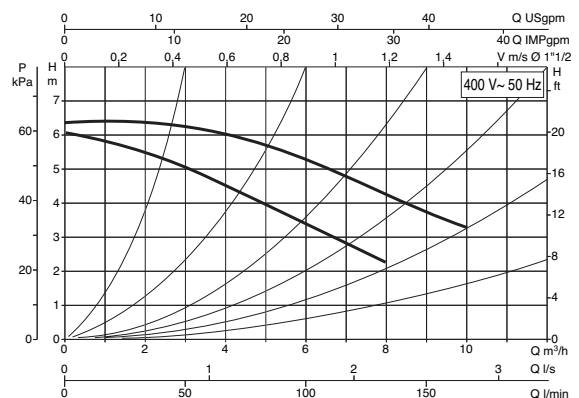

A 80/180 XM -

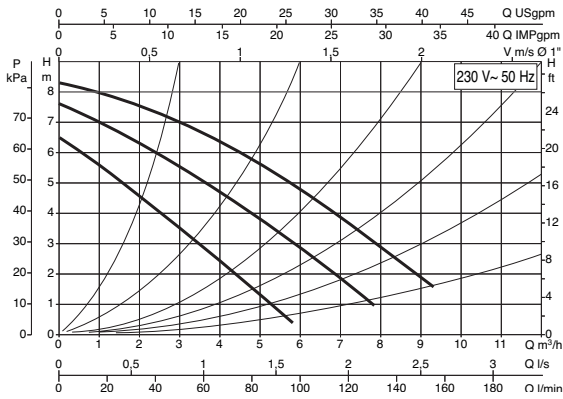

A 80/180 M - B 80/250.40M - D 80/250.40M

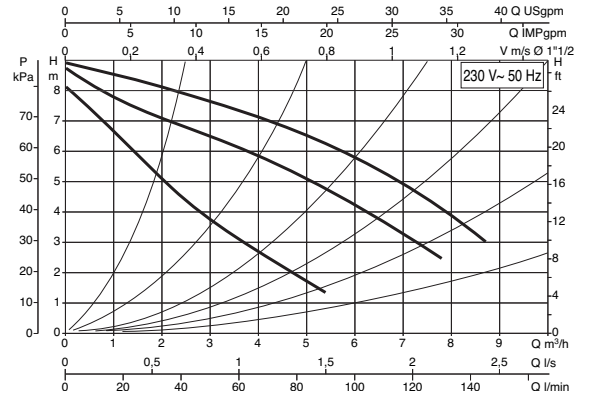

A 80/180 XT

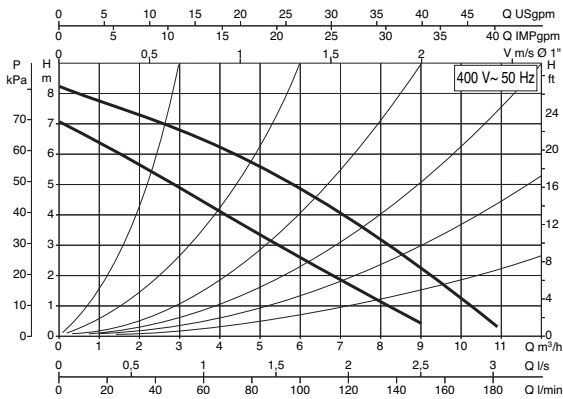

A 80/180 T - B 80/250.40T - D 80/250.40T

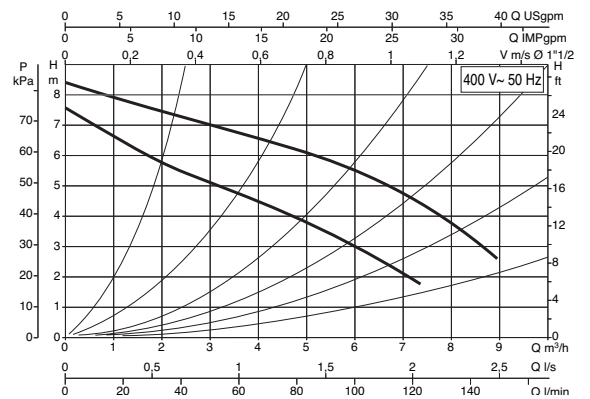

A 110/180 XM - B 110/250.40 M - D 110/250.40 M

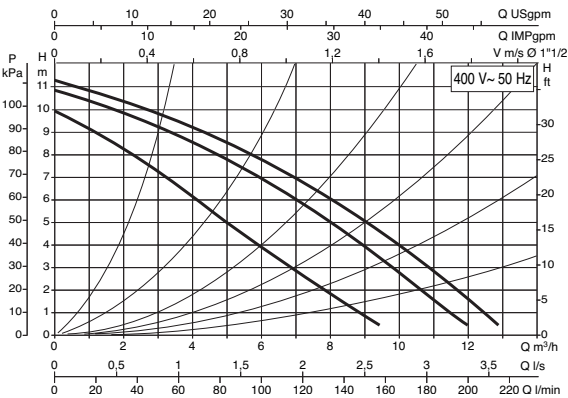

A 110/180 XT - B 110/250.40 T - D 110/250.40 T

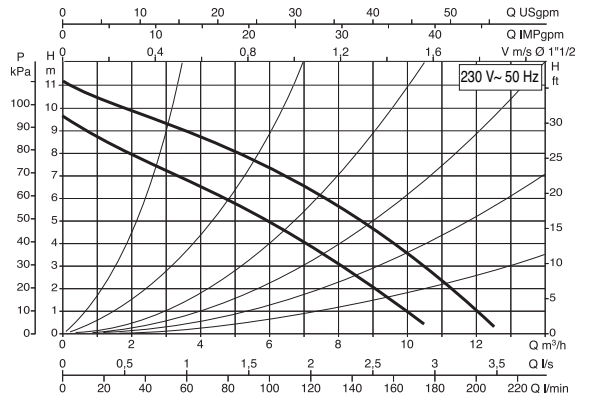

DIMENSIONS AND WEIGHTS

A 50-56-80/...M-T

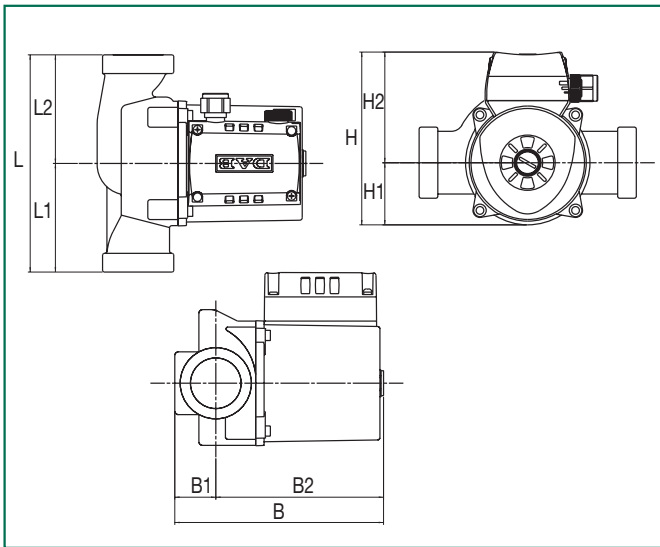

A 110/...M-T

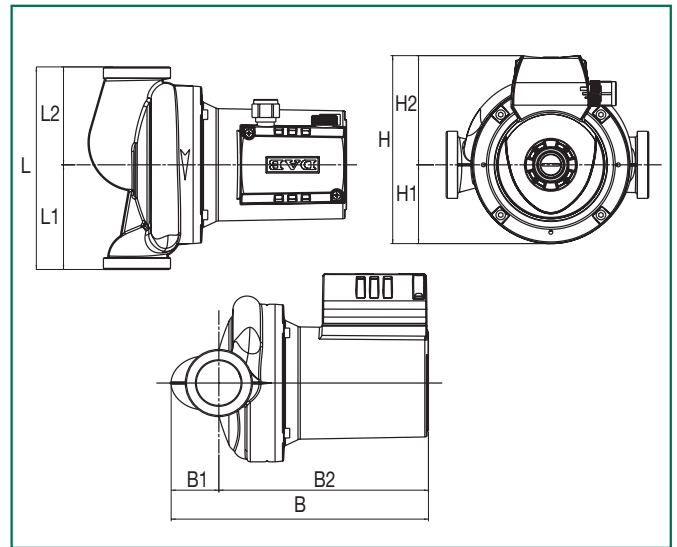

B 50-56-80/...M-T

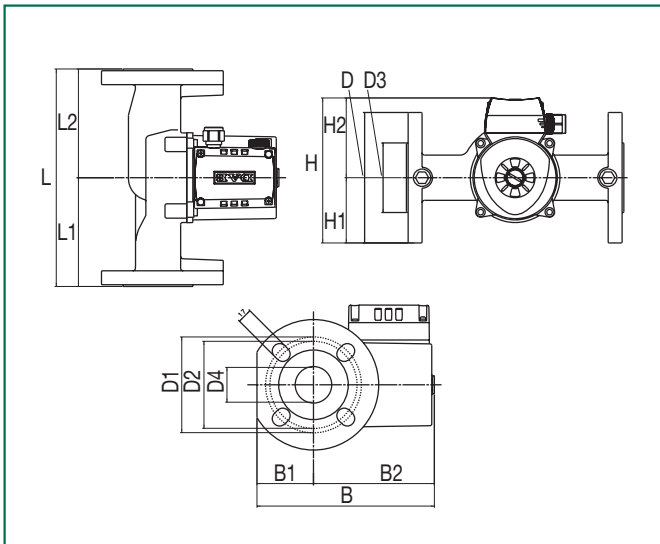

B 110/...M-T

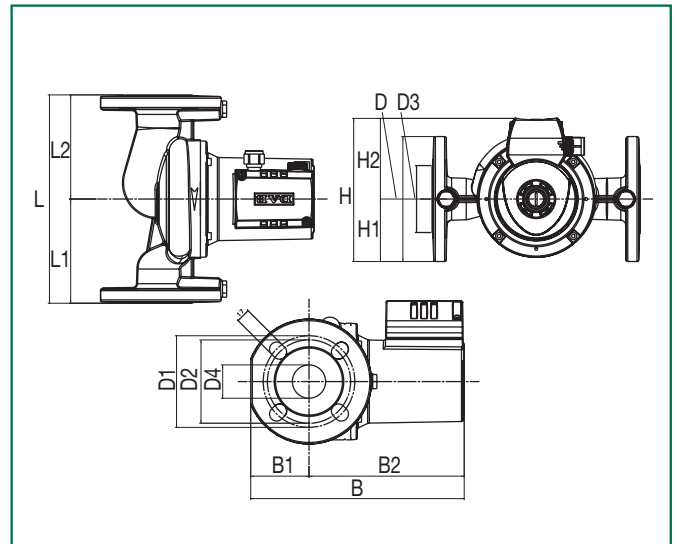

D 50-56-80/...M-T

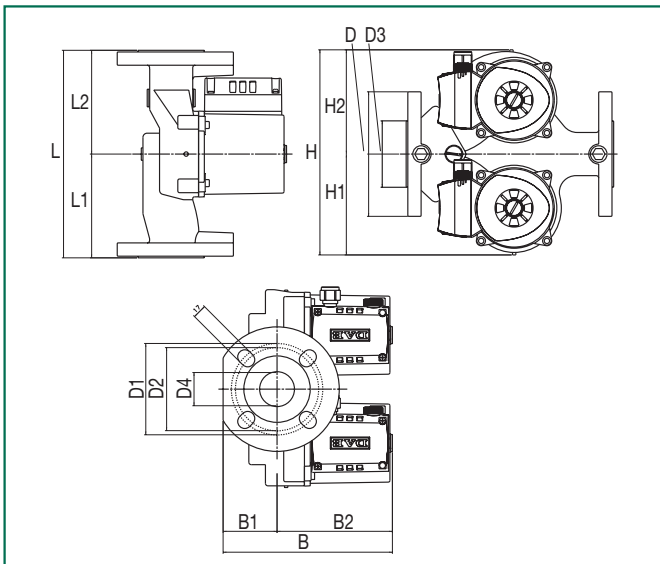

D 110/...M-T

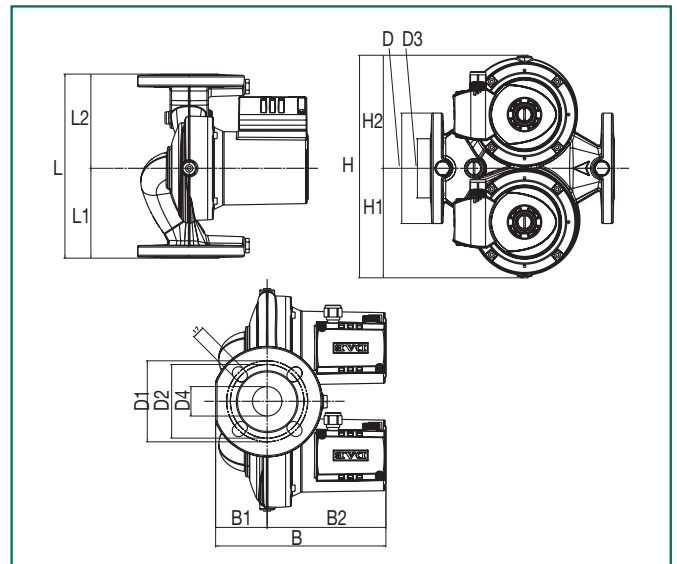

MODEL	L	L1	L2	A	B	B1	B2	D	D1	D2	D3	D4	H	H1	H2	F	WEIGHT
A 50/180 XM	180	90	90	–	173	34	139	–	–	–	–	–	143	52	92	2"G	4,8
A 50/180 M	180	90	90	–	173	34	139	–	–	–	–	–	143	52	92	1"1/2	4,8
A 50/180 XT	180	90	90	–	173	34	139	–	–	–	–	–	143	52	92	2"G	5
A 50/180 T	180	90	90	–	173	34	139	–	–	–	–	–	143	52	92	1"1/2	5
A 56/180 XM	180	90	90	–	173	34	139	–	–	–	–	–	143	52	92	2"G	4,8
A 56/180 M	180	90	90	–	173	34	139	–	–	–	–	–	143	52	92	1"1/2	4,8
A 56/180 XT	180	90	90	–	173	34	139	–	–	–	–	–	143	52	92	2"G	5
A 56/180 T	180	90	90	–	173	34	139	–	–	–	–	–	143	52	92	1"1/2	5
A 80/180 XM	180	90	90	–	173	34	139	–	–	–	–	–	143	52	92	2"G	4,8
A 80/180 M	180	90	90	–	173	34	139	–	–	–	–	–	143	52	92	1"1/2	4,8
A 80/180 XT	180	90	90	–	173	34	139	–	–	–	–	–	143	52	92	2"G	5
A 80/180 T	180	90	90	–	173	34	139	–	–	–	–	–	143	52	92	1"1/2	5
A 110/180 XM	180	93	87	–	229	42	186	–	–	–	–	–	167	70	97	2"G	7,5
A 110/180 XT	180	93	87	–	229	186	42	–	–	–	–	–	163	70	93	2"G	7,7

MODEL	L	L1	L2	A	B	B1	B2	D	D1	D2	D3	D4	H	H1	H2	F	WEIGHT
B 50/250.40 M	250	125	125	–	204	65	139	150	110	100	80	40	167	75	92	DN40/ PN10	8,6
B 50/250.40 T	250	125	125	–	204	65	139	150	110	100	80	40	167	75	92	DN40/ PN10	8,8
B 56/250.40 M	250	125	125	–	204	65	139	150	110	100	80	40	167	75	92	DN40/ PN10	8,6
B 56/250.40 T	250	125	125	–	204	65	139	150	110	100	80	40	167	75	92	DN40/ PN10	8,8
B 80/250.40 M	250	125	125	–	204	65	139	150	110	100	80	40	167	75	92	DN40/ PN10	8,6
B 80/250.40 T	250	125	125	–	204	65	139	150	110	100	80	40	167	75	92	DN40/ PN10	8,8
B 110/250.40 M	250	125	125	–	256	70	186	150	110	100	80	40	172	75	97	DN40/ PN10	9,4
B 110/250.40 T	250	125	125	–	256	70	186	150	110	100	80	40	168	75	93	DN40/ PN10	9,6

MODEL	L	L1	L2	A	B	B1	B2	D	D1	D2	D3	D4	H	H1	H2	F	WEIGHT
D 50/250.40 M	250	125	125	–	204	65	139	150	110	100	80	40	247	122	126	DN40/ PN10	14,2
D 50/250.40 T	250	125	125	–	204	65	139	150	110	100	80	40	247	122	126	DN40/ PN10	14,8
D 56/250.40 M	250	125	125	–	204	65	139	150	110	100	80	40	247	122	126	DN40/ PN10	14,2
D 56/250.40 T	250	125	125	–	204	65	139	150	110	100	80	40	247	122	126	DN40/ PN10	14,8
D 80/250.40 M	250	125	125	–	204	65	139	150	110	100	80	40	247	122	126	DN40/ PN10	14,2
D 80/250.40 T	250	125	125	–	204	65	139	150	110	100	80	40	247	122	126	DN40/ PN10	14,8
D 110/250.40 M	250	122	128	–	231	70	161	150	110	100	80	40	302	149	154	DN40/ PN10	17,8
D 110/250.40 T	250	122	128	–	231	70	161	150	110	100	80	40	302	149	154	DN40/ PN10	18,0