



INDUSTRIAL DUTY

Cast Iron Sewage & Trash Pumps

- **Cast Iron Construction**
- **Silicon Carbide/Viton Mechanical Seal**
- **2", 3" & 4" NPT Port Sizes**
- **Self-Priming up to 20 ft.**
- **Maximum Temperature 180° F**
- **Maximum Working Pressure 150 PSI**
- **Stainless Steel Semi-open, Clog Resistant Impeller**
- **Buna-N Check Valve & O-Ring**
- **Removable Cast Iron Volute/Wearplate**
- **Easy Cleanout Design**
- **Pull-from-Rear Design**
- **3" & 4" Models Feature Front Cleanout**
- **Available with 3 to 15 HP Totally Enclosed Fan Cooled (TEFC) Electric Motors**
- **Single and Three Phase, 3450 RPM Motors**
- **Seal Flush Port Provided on 5 HP and Larger**
- **Optional Mounting Base Available**



Cast Iron Sewage & Trash Pump

AMT Cast Iron Sewage/Trash pumps are designed for trouble free and economical handling of solids laden liquids and slurries. Pumps are available in three NPT port sizes; 2", 3" and 4". Cast iron construction with 2 vane Stainless Steel self-cleaning impellers, Silicon Carbide mechanical seals for abrasion resistance and Buna-N O-rings and check valves. Built-in check valve allows pump to reprime automatically in an open system, without a foot valve. The solids handling capabilities of the pumps make them ideally suited for a variety of industrial applications including: sewage treatment, canneries, chemical processing, wineries, tanneries, meat packing, breweries, pulp, wood chips, process water, sludge and slime, waste water, white water and other applications.

AMT Sewage/Trash pumps will easily handle liquids containing sewage, stone, sticks, mud, and other solids. Minimum liquid requirement must be above 85%. Failure to do so may damage pump and void warranty. These pumps are reliable, cost effective and low maintenance. Many are readily available "Off-the-Shelf" for fast 24 hour shipment. For use with non-flammable liquids compatible with pump component materials.

Maximum 15% Solids

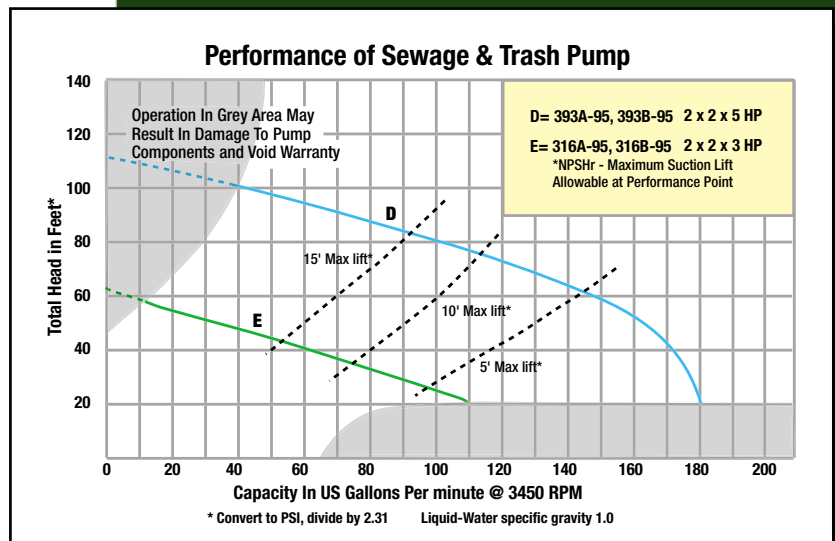
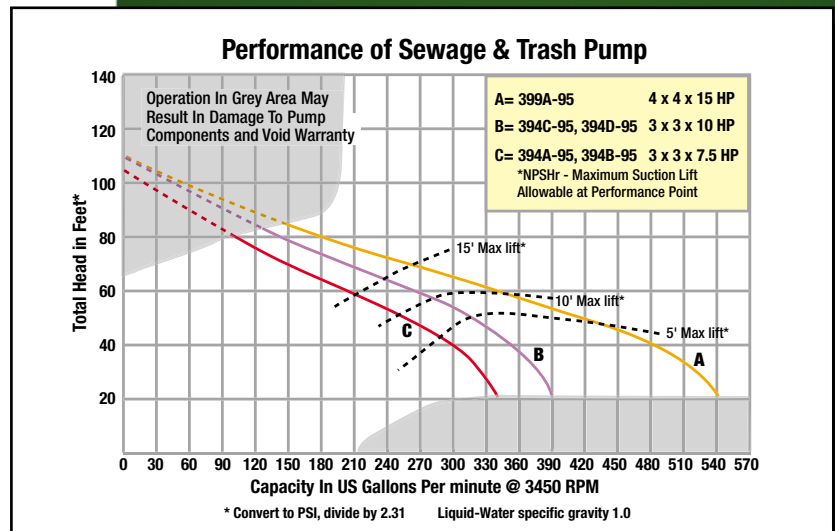

Cast Iron Sewage & Trash Pumps

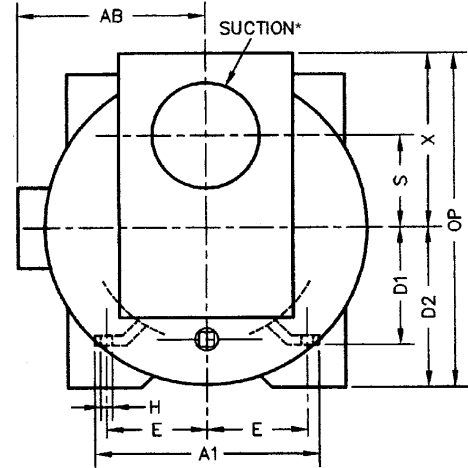
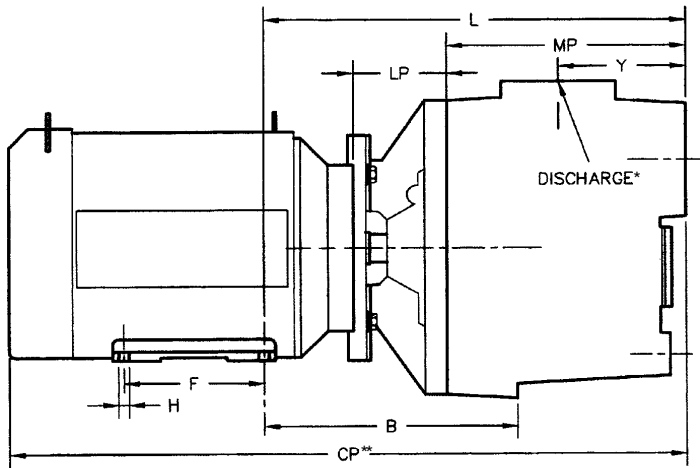

Pump Dimensional Chart

Model No.	HP	SUC*	DIS*	CP**	A1	Width	AB	B	D1	D2	E	F	H	L	LP	MP	OP	S	X	Y	Ship Wt.
316A-95	3	2"	2"	21.0	6.5	9.0	5.0	N/A	3.5	N/A	2.4	3.0	0.88 x 0.34	11.0	2.3	6.1	8.2	2.1	4.7	3.1	87 lbs.
316B-95	3	2"	2"	21.0	6.5	9.0	5.0	N/A	3.5	N/A	2.4	3.0	0.88 x 0.34	11.0	2.3	6.1	8.2	2.1	4.7	3.1	94 lbs.
393A-95	5	2"	2"	25.0	6.4	13.5	8.6	9.7	4.5	5.2	3.7	5.5	0.4	14.8	4.4	6.9	10.	2.1	4.7	3.1	146 lbs.
393B-95	5	2"	2"	25.0	6.4	13.5	8.6	9.7	4.5	5.2	3.7	5.5	0.4	14.8	4.4	6.9	10.	2.1	4.7	3.1	170 lbs.
394A-95	7.5	3"	3"	26.5	6.4	15.5	9.4	10.0	4.5	5.7	3.7	5.5	0.4	16.5	3.7	9.3	12.4	3.5	6.6	5.0	200 lbs.
394B-95	7.5	3"	3"	31.0	9.5	15.5	9.4	10.8	5.2	5.7	4.2	7.0	0.4	17.4	3.7	9.3	12.4	3.5	6.6	5.0	255 lbs.
394C-95	10	3"	3"	31.0	9.5	15.5	9.5	10.8	5.2	5.7	4.2	7.0	0.4	17.4	3.7	9.3	12.4	3.5	6.6	5.0	215 lbs.
394D-95	10	3"	3"	31.0	9.5	15.5	9.5	10.8	5.2	5.7	4.2	7.0	0.4	17.4	3.7	9.3	12.4	3.5	6.6	5.0	285 lbs.
399A-95	15	4"	4"	32.0	9.5	15.5	9.5	11.2	5.2	6.1	4.2	7.0	0.4	18.5	3.7	10.3	14.3	3.5	8.1	6.6	287 lbs.

Pump Specification Chart

Model No.	Curve	HP	PH	ENC	Frame	Voltage @ 60 Hz+	Full Load Amps	Max Solids
316A-95	E	3	3	TEFC	56J	230/460	8/4	1"
316B-95	E	3	1	TEFC	56J	230	16	1"
393A-95	D	5	3	TEFC	184JM	230/460	17/9	1"
393B-95	D	5	1	TEFC	184JM	230	20	1"
394A-95	C	7-1/2	3	TEFC	184JM	230/460	22/11	1-1/2"
394B-95	C	7-1/2	1	TEFC	215JM	230	31	1-1/2"
394C-95	B	10	3	TEFC	215JM	230/460	26/13	1-1/2"
394D-95	B	10	1	TEFC	215JM	230	40	1-1/2"
399A-95	A	15	3	TEFC	215JM	230/460	47/24	2"

(*) Standard NPT (female) pipe thread.

(**) This dimension may vary due to motor manufacturer's specifications.

(+) 3-Phase motors can operate on 50 Hz. (This will change Full Load Amps, Service Factor, RPM and Priming Capabilities)

NOTE: Dimensions have a tolerance of $\pm 1/8"$.

NOTE: Electric supply for ALL motors must be within $\pm 10\%$ of nameplate voltage rating (Ex. 230V $\pm 10\%$ = 207 to 253)

Standard Features

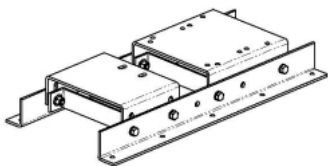

**Optional Mounting Base
Model # A200-90**

- ▶ Cast Iron Construction for Abrasive Resistance and Durability
- ▶ Self-cleaning Stainless Steel Impellers Resist Clogging and Wear
- ▶ Pull-from-Rear Design Permits Clean Out and Repair Without Removing Piping
- ▶ Silicon Carbide/Viton Mechanical Seal
- ▶ Built in Buna-N Check Valve
- ▶ Buna-N O-Ring Casing Seal Reusable After Clean Out Maintenance
- ▶ Replaceable Cast Iron Volute/Wearplate Designed for Solids Handling
- ▶ Motor Includes Stainless Steel Shaft or Stainless Steel Shaft Sleeve
- ▶ 3" & 4" Models Feature Front Cleanout
- ▶ Available with 3 to 15 HP Totally Enclosed Fan Cooled (TEFC) Electric Motors
- ▶ Single and Three Phase, 3450 RPM Motors
- ▶ Optional Mounting Base Available for 184/215 JM Frames (Reference pgs. 41-42)