



**AMERICAN-MARSH PUMPS**

*“DURABILITY BY DESIGN SINCE 1873”*

# **340 Series Double Suction Split Case Pumps**

Flows to: 73,000 GPM  
Heads to: 550 Feet  
Temperatures to: 250° F

## 135 Years of Pump Manufacturing

American-Marsh Pumps, one of the oldest pump lines in America, are pump products steeped in heritage. Since 1873, the American-Marsh line of pumps has withstood the test of time. During the last 135 years, over 100 varieties of pumps have been designed and built. From steam pumps to centrifugal pumps, American-Marsh pumps have been built to meet the ever changing requirements of society. Over the last century through continuous product development, more American-Marsh models have been retired than most other pump manufacturers have ever produced. Hundreds of thousands of pumps have been made, all designed for longevity, allowing many of them to continue servicing customers over 50 years.

All of our pumps have three superior characteristics; Design, Performance, and Durability. Our engineering department, which includes an in-house pattern shop, designs each pump so that installation and maintenance is easy. Our performances are engineered to meet or beat the competition in each category. For 135 years, American-Marsh Pumps products have

provided cost effective solutions by building pumps to last. Durability by design is always the most cost effective solution. From engineering and design to final assembly, experienced people control each step of the manufacturing process with quality control inspections performed at each step. All pumps shafts are heat straightened. All impellers are computer balanced. Pump testing is done in our new state of the art test facility. All of these factors ensure you receive consistent quality product every time.

American-Marsh Pumps has provided quality pump products for over 135 years. At American-Marsh Pumps, we know that long life and superior performance are the keys to satisfied customers. By understanding your needs, we can design products that meet those needs. Our product family reflects years of customer input, product upgrades, redesign and new product development, all focused on meeting and exceeding your expectations.

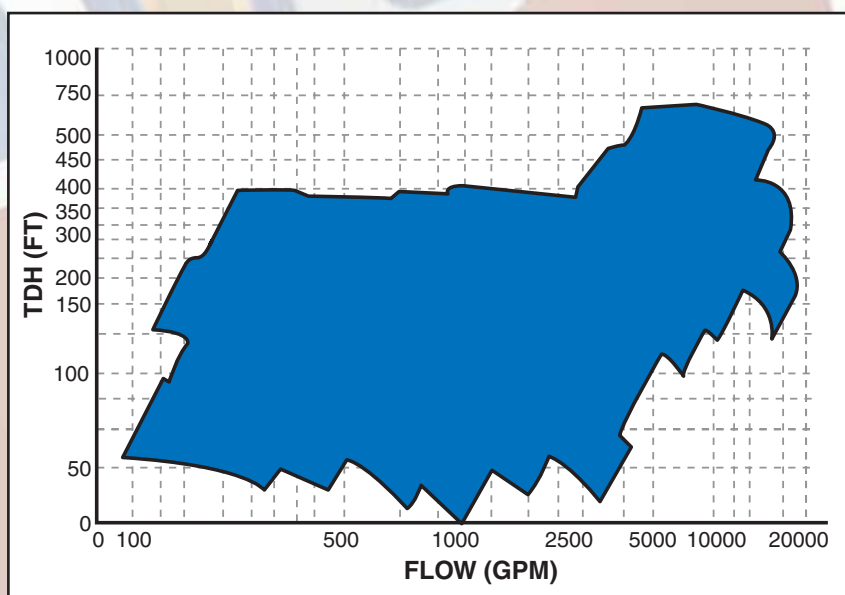



## Specifications HD & V-HD Series

**Casing:** The casing is of high tensile cast iron or other specified material. It is of the volute type with double suction, split on the horizontal centerline with the suction and discharge nozzles cast integral with the lower half. Suction and discharge nozzles are casted of 250 psi dimensions and all models feature a 250 psi case working pressure. Removal of the upper casing gives complete access to the interior of the pump without disturbing piping connections or pump alignment. The casing utilizes Thru-Bore lineboring technology simplifying the machining operation and allows the advantage of using only a few modular rotating assemblies. The Thru-Bore feature allows for the complete removal and replacement of the stuffing boxes without replacing the casing.

V-HD models include the above details but also feature a casted base and casted motor bracket for mounting the pump in the vertical orientation. In addition to this, the lower roller bearing has been removed and replaced by a heavy duty, fluted bushing designed to keep the rotor assembly in perfect alignment. The top single roller bearing has also been modified into a double row taper roller bearing to withstand all axial thrusts generated by the pumping assembly. This enhanced bearing design allows for no roller bearing to be present under the pump where fluid and other contaminants can get into this bearing assembly (as can be seen in competitor pumps).

**Impeller:** The impeller is of the double suction, enclosed, nonoverloading type. It is made of bronze, or other specified material, machined and polished all over and dynamically and hydraulically balanced. The impeller is keyed to the shaft and secured by locknuts. It is adjustable for position.

**Case Wear Rings:** Case wear rings are made of bronze or other specified material. They are designed with a large wearing surface with the diameter at wearing surface reduced to a minimum, and are firmly secured in the casing by dowel pins.

**Shaft:** The shaft is of 420 stainless steel, ground and polished to a smooth surface. It is designed for extra stiffness to avoid all critical speeds in operation, and is threaded for bearing and impeller lock nuts. The portion of the shaft that is exposed to the pumped fluid is covered with renewable bronze shaft sleeves screwed on against the impeller with right and left hand threads which cannot work loose during operation. Shaft sleeves have external o-rings, in lieu of internal o-rings, to stop leakage of product.

**Stuffing Boxes/Seal Chambers:** The stuffing boxes/seal chambers are extra deep, being designed for packing and lantern ring or mechanical seals. Under each stuffing box is a drip pocket with tapped drain outlet. The stuffing boxes/seal chambers are completely removable and replaceable.

**HD Bearings:** Both the inboard and outboard ball bearings are of the single row, deep groove type, precision grade, with cartridge mounting, permitting the removal of the bearings without removing the top casing assembly. They are of extra large capacity for both radial and thrust loads. The outboard bearing is confined rigidly in the bearing housing to take end thrust, while the inboard bearing is set with sufficient clearance to allow for shaft expansion. All bearings are sized to maintain a minimum of 50,000 hour bearing life. Each bearing is designed for grease lubrication and is provided with a water slinger to prevent leakage from the stuffing box into the bearing. A zerk fitting is furnished for each bearing. Each bearing housing is sealed from water leakage by the use of an oil lip seal. Both bearings can be removed and replaced without removing the rotating assembly from the pump, greatly simplifying the repair process.

**V-HD Bearing/Bushing:** The inboard, double row, precision grade roller bearing is designed for unplanned loads for both radial and axial thrust loads. This inboard roller bearing is sized to maintain a minimum bearing life of 50,000 hours. This bearing is designed for grease lubrication and is provided with a zerk fitting and oil lip seal to keep contaminants out of the bearing housing. This double row roller bearing can be inspected and removed without removing the top casing assembly.

The outboard bushing is a heavy wall, fluted bronze bushing designed to keep the rotor assembly in perfect alignment. This bushing is product lubricated standard but can be set up to accept external lubrication upon request. Several different Class clearances can be engineered depending upon fluid cleanliness. The significant advantage to this bushing design is that no grease lubricated, roller bearing is present under the pump assembly where leakage from the casing could cause contamination and eventual bearing failure. This bushing design allows for the vertical split case pump to be packed or mechanically sealed.



# Model HD Pump

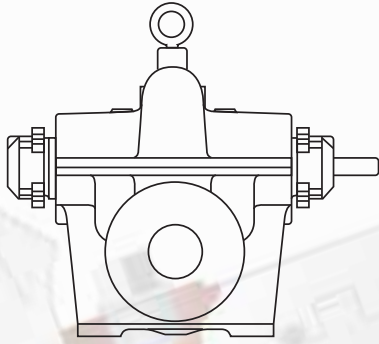

Double Suction Impeller

**Sizes:** 2" to 32+"  
**Flows:** 30,000+ GPM  
**Heads:** 550 Feet  
**Temp:** 250° F

## Services:

-  Aerospace
-  Building Trades
-  Chemical
-  General Industry
-  Marine
-  Mining & Aggregate
-  Oil & Gas
-  Power Generation
-  Petro-Chemical
-  Pharmaceutical
-  Pulp & Paper
-  Semiconductor
-  Water & Wastewater

## Heavy Duty Casing

- Standard ASTM A48 Class 30 cast iron
- Horizontally split for easy access
- Casing has Thru-Bore which allows the removal of the entire rotating assembly, including both stuffing boxes, and the entire bearing housing assembly
- Heavy wall thickness to provide generous corrosion allowance and high working pressures
- Volute type casing with double suction provides suction and discharge nozzles cast integral with the lower half of the casing
- Suction and discharge connections are in lower half, allowing removal or inspection of upper half and rotating assembly without disturbing piping or driver
- Alternate metallurgy available as an option
- Standard 250 lb case working pressure

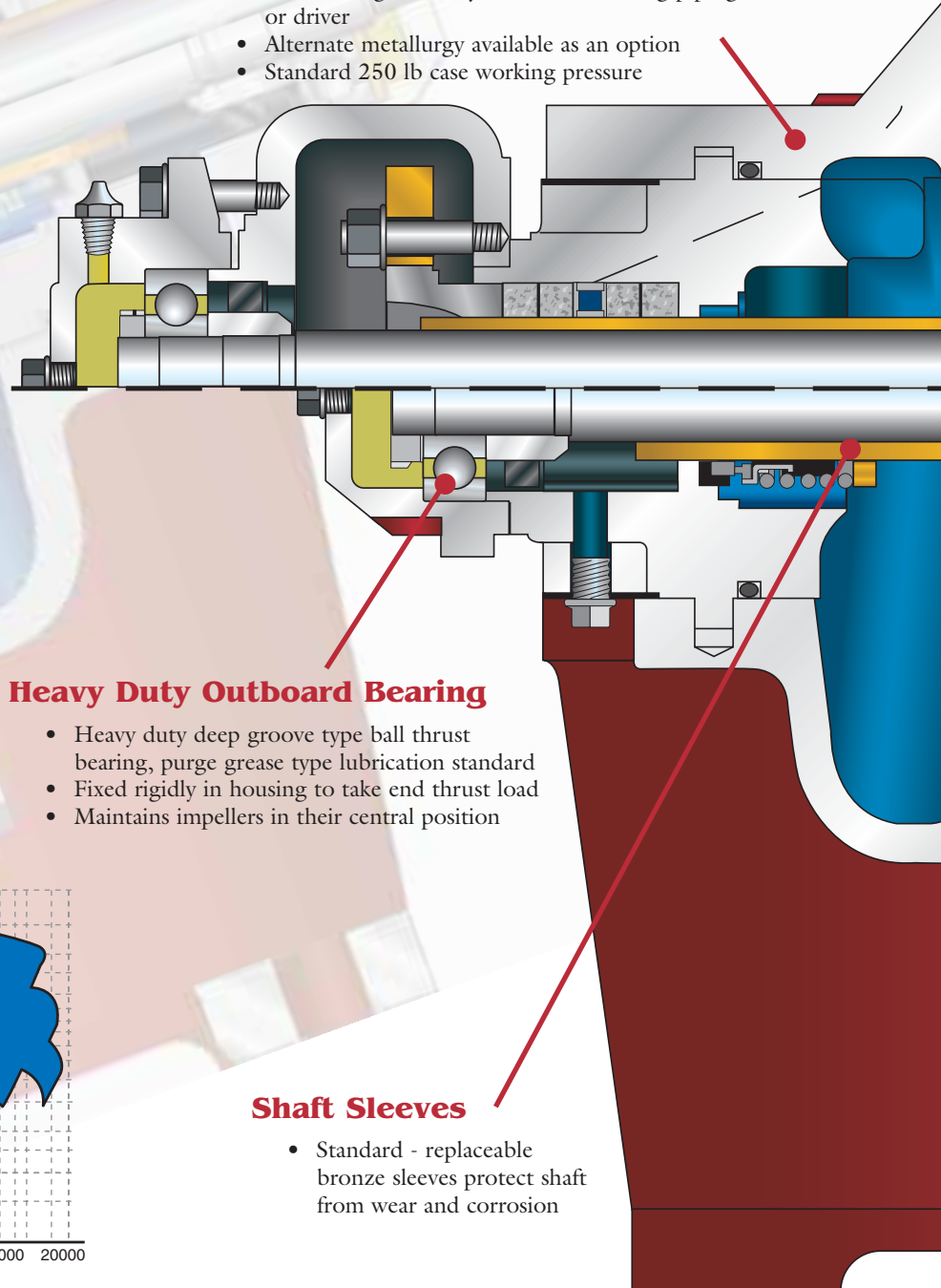

## Heavy Duty Outboard Bearing

- Heavy duty deep groove type ball thrust bearing, purge grease type lubrication standard
- Fixed rigidly in housing to take end thrust load
- Maintains impellers in their central position

## Shaft Sleeves

- Standard - replaceable bronze sleeves protect shaft from wear and corrosion

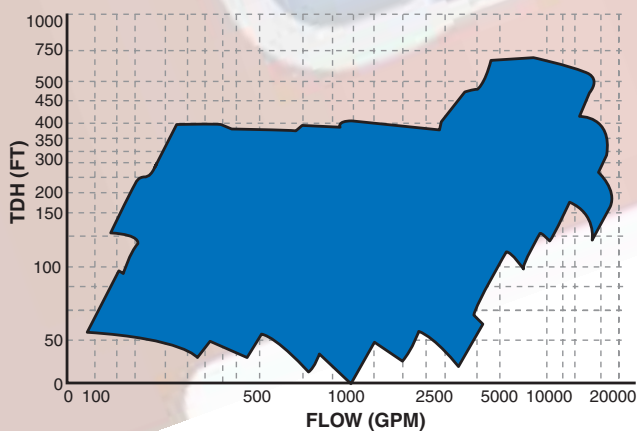

## Impellers

- Double suction minimizes axial thrust, enclosed, non-overloading bronze standard, other alloys available
- Expertly machined to customer specifications
- Fully balanced before assembly

## Casing Wear Rings

- Standard bronze or other specified alloy
- Renewable, permits easy maintenance of proper running clearances
- Allows smooth transfer of fluid into impeller eye, increasing efficiency and lowering NPSH
- Pinned to prevent rotation

## Bearing Housings

- Cartridge bearing arrangement allows the removal of the entire bearing housing assembly with the rotating element.
- Both the inboard and outboard bearing can be completely replaced without disturbing any other part of the rotating assembly.
- Both bearings are protected by lip seals to keep contaminants out of bearing housing

## Heavy Duty Inboard Bearing

- Heavy duty deep groove type ball bearing, purge grease type lubrication standard
- Carries radial load; free to move axially

## Stuffing Boxes

- When packed, supplied with a bronze lantern ring and gland
- When sealed, supplied with an American-Marsh Series 810 Carbon/Silicon-Carbide/EPDM mechanical seal
- Other component and cartridge seals available on request
- Fully removable with the rotating assembly
- Both stuffing boxes have integral vortex suppressors to minimize inlet losses

## Heavy Duty Shaft

- Designed and sized especially for the pump and its applications
- 420 stainless steel shaft standard

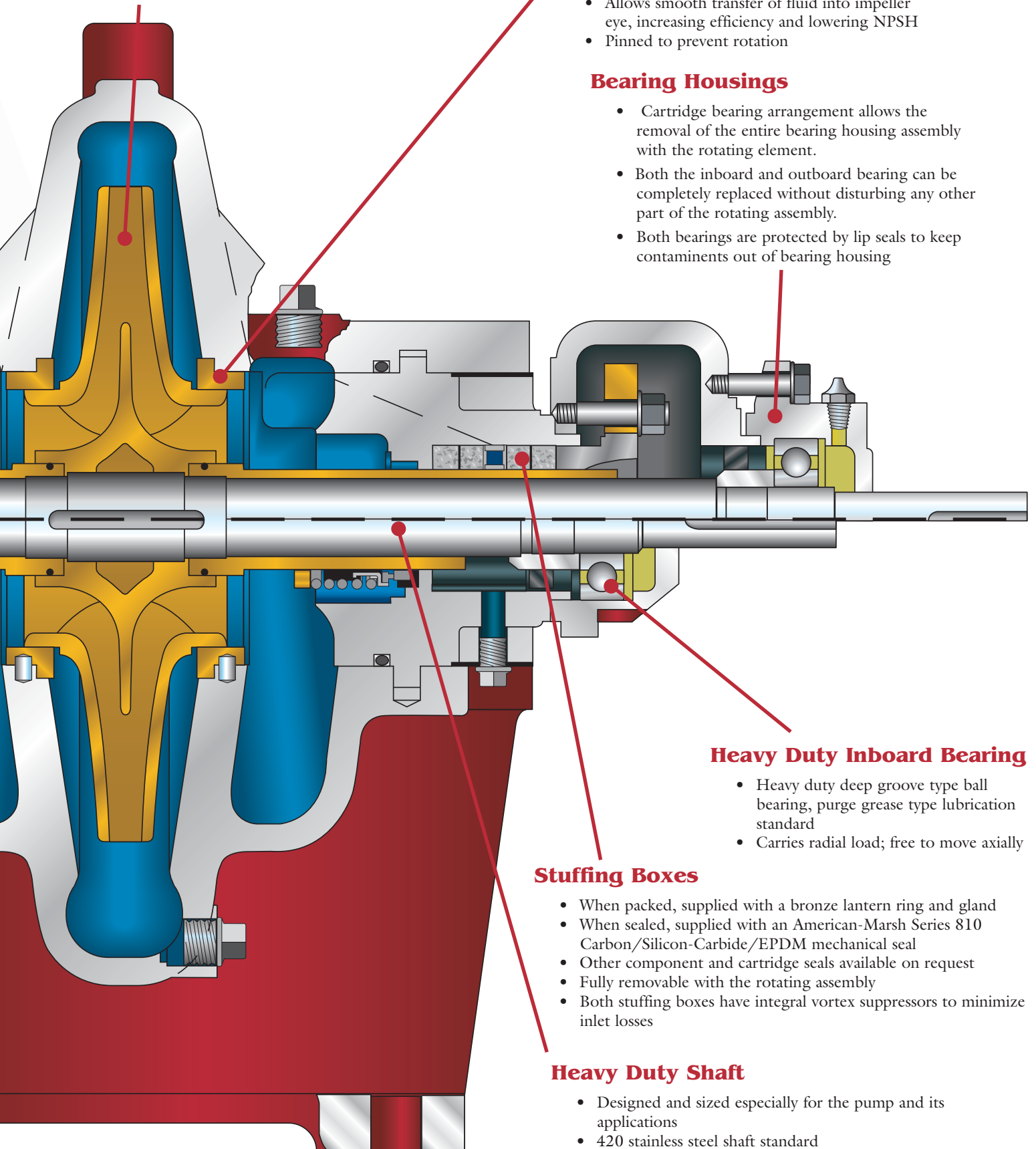

# Model V-HD Pump

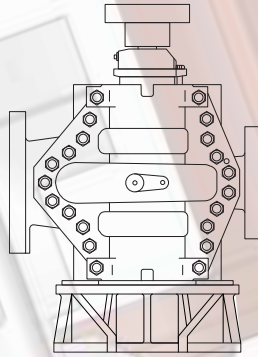

Double Suction Impeller

**Sizes:** 2" to 32+"  
**Flows:** 30,000+ GPM  
**Heads:** 550 Feet  
**Temp:** 250° F

## Services:

-  Aerospace
-  Building Trades
-  Chemical
-  General Industry
-  Marine
-  Mining & Aggregate
-  Oil & Gas
-  Power Generation
-  Petro-Chemical
-  Pharmaceutical
-  Pulp & Paper
-  Semiconductor
-  Water & Wastewater

## Casing Wear Rings

- Standard bronze or other specified alloy
- Renewable, permits easy maintenance of proper running clearances
- Pinned to prevent rotation

## Heavy Duty Casing

- Standard ASTM A48 Class 30 cast iron
- Horizontally split for easy access
- Heavy wall thickness to provide generous corrosion allowance and high working pressures
- Volute type casing with double suction provides suction and discharge nozzles cast integral with the lower half of the casing
- Suction and discharge connections are in lower half, allowing removal or inspection of upper half and rotating assembly without disturbing piping or driver
- Alternate metallurgy available as an option
- Standard 250 lb case working pressure

## Impellers

- Double suction minimizes axial thrust, enclosed, non-overloading bronze standard, other alloys available
- Expertly machined to customer specifications
- Fully balanced before assembly

## Lower Bearing Housing

- Engineered, heavy duty bushing designed to support the rotating assembly and offset radial forces generated by the rotating assembly
- Superior design as compared to competition because no roller bearing exists in this location. Fluid entering the lower roller bearing housing is a number one cause that competitor pumps fail.
- The bearing can be supplied in optional material or hardened based on customer application.
- The bearing can be fluted on abrasive applications allowing for a superior method of lubrication.
- Internal and external flushing is standard on the lower bearing housing. If the internal fluid is not suitable for flushing the housing can be set up to accept external fluid.

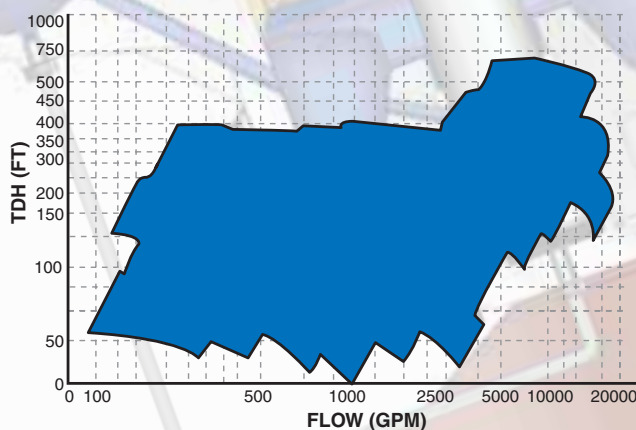



## Drivers

- Assemblies can be close- or flex-coupled engineered to customer specifications

## Heavy Duty Shaft

- Designed and sized especially for the pump and its applications
- 420 stainless steel shaft standard

## Upper Bearing Housing

- Heavy duty deep groove type, double row bearing, purge grease type lubrication standard and is cartridge mounted to permit easy removal of rotating element
- Double row roller bearing is protected by a lip seal to keep contaminants out of bearing housing
- Double row bearing carries both the radial and axial forces generated by the rotating assembly

## Stuffing Box

- When packed, supplied with a bronze lantern ring and gland
- When sealed, supplied with an American-Marsh Series 810 Carbon/Silicon-Carbide/EPDM mechanical seal
- Other component and cartridge seals available on request

## Shaft Sleeve

- Standard - replaceable bronze sleeve protects shaft from wear and corrosion

## Heavy Duty Integral Base

- Casted or fabricated steel designed and sized for the pump and its application
- The base can be designed for close-coupled or flex-coupled, shaft driven driver

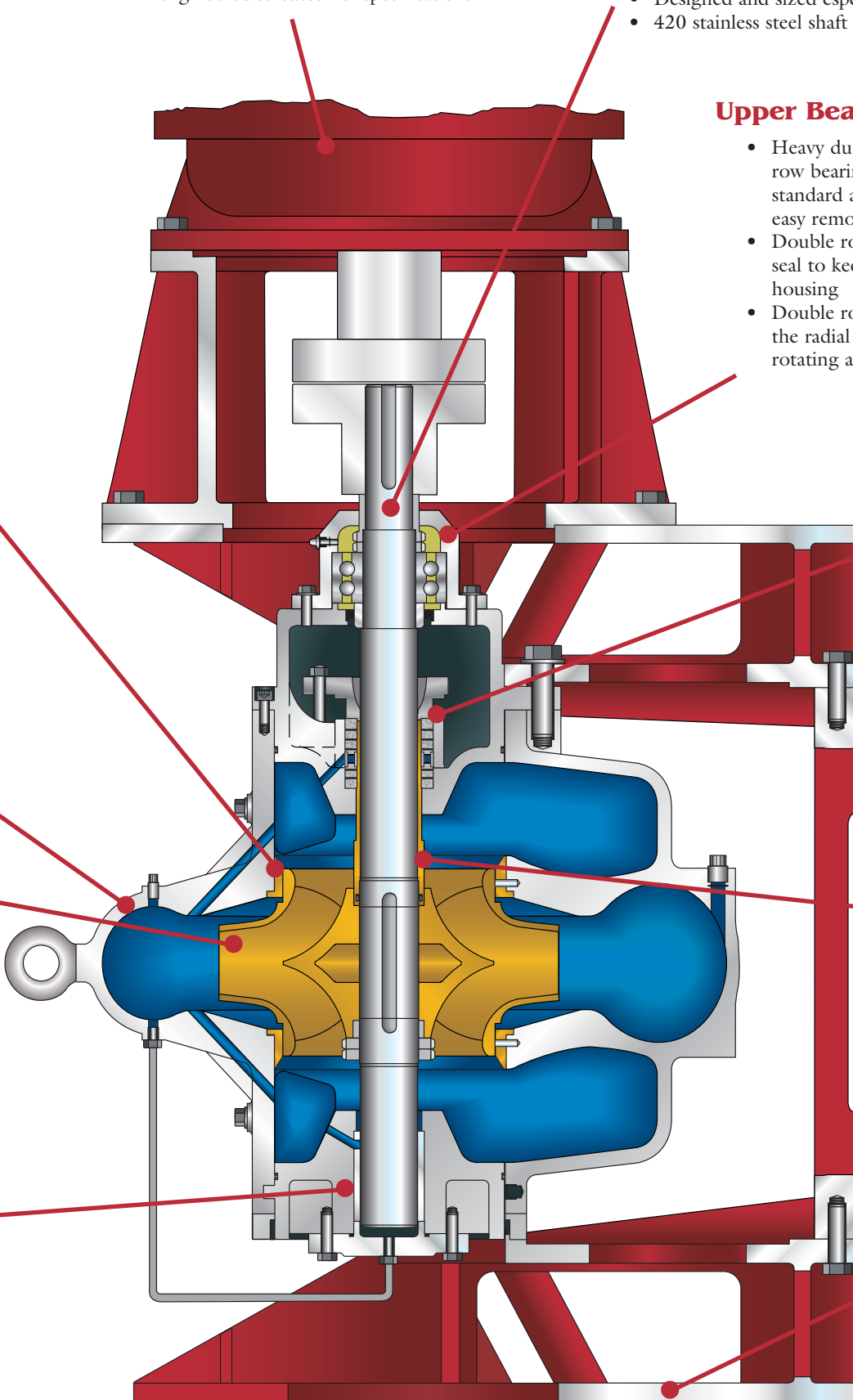

Our long tradition of quality pump manufacturing began in 1873 making us one of the first pump manufacturers in this country. *American-Marsh Pumps* provides the user dependability and durability. Durability by design is always the most cost effective solution.

**Nearly all designs are available in alternate metallurgy constructions.**

**HEAVY DUTY SHAFTS**

American-Marsh Pumps standard product design includes 420 stainless steel shafts with high tensile strength designed for minimum shaft deflection. Each shaft is machined to close tolerance and designed to exceed HP requirements of each pump.

**HEAVY DUTY CASING**

Casing is split on the horizontal centerline and provided with extra thick casing walls. Rugged design resists external forces and vibration. Rotating element can be inspected and/or removed without disturbing piping or driver.

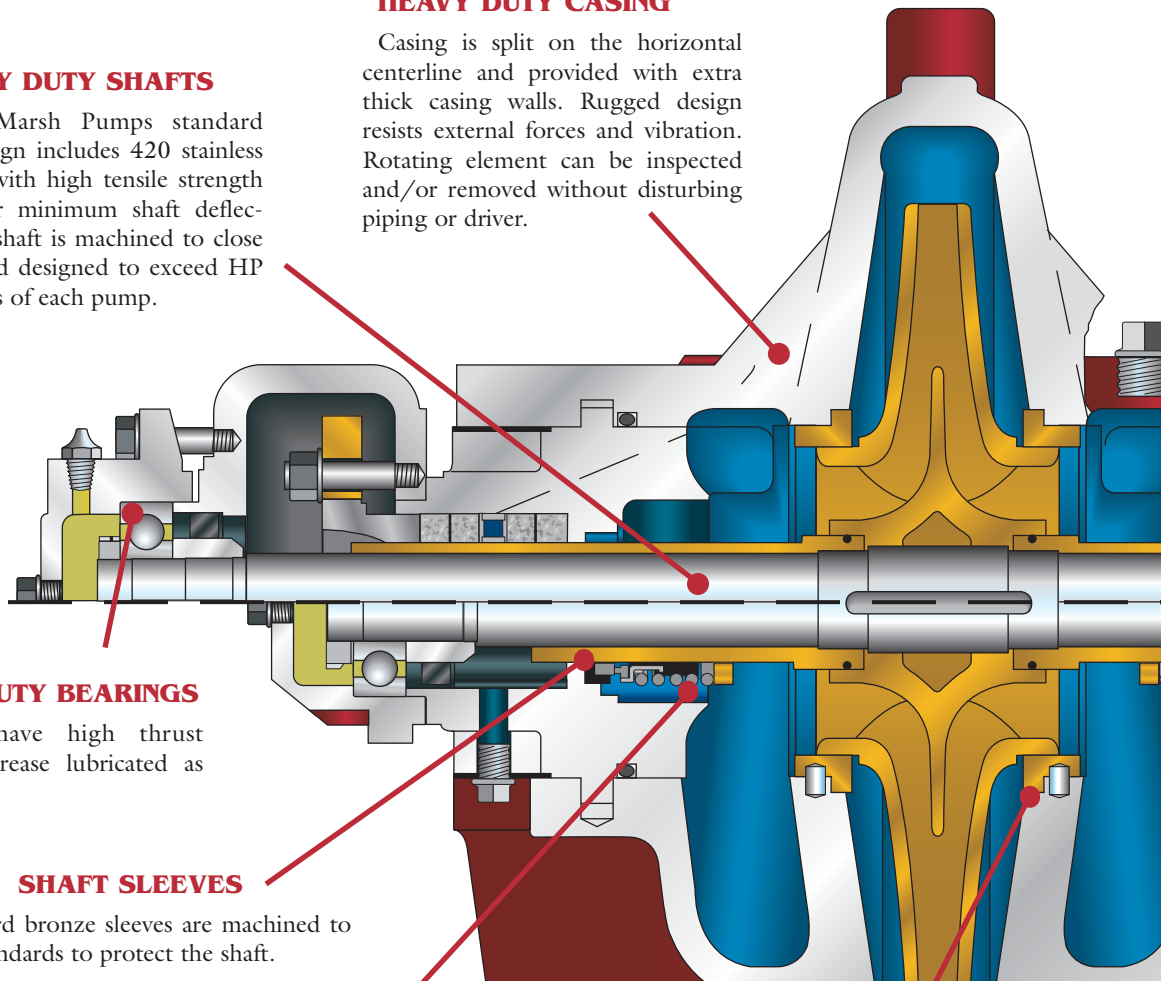

**HEAVY DUTY BEARINGS**

Bearings have high thrust capability. Grease lubricated as standard.

**SHAFT SLEEVES**

Standard bronze sleeves are machined to exact standards to protect the shaft.

**MECHANICAL SEALS/ PACKING**

Stuffing Box can be provided with low leak packing or mechanical seal as required by the customer and application.

**WEAR RINGS**

Standard case wear rings permit easy maintenance of proper running clearances, and are oversized with large wearing surfaces to extend the life of each pump. Rings are available in bronze, iron, stainless steel or other alloys as required.

**OTHER PUMP PRODUCTS**

**MULTI-STAGE**  
To 8" Discharge  
4800 GPM, 2100'

**END SUCTION**  
To 12" Discharge  
9000 GPM, 450'

**VERTICAL SUMP**  
To: 12" discharge  
9000 GPM, 450'

**REGENERATIVE TURBINE**  
To 2-1/2" Discharge  
140 GPM, Heads to 750'

**SELF PRIMER**  
To 12" Discharge  
6400 GPM, 260'

**American-Marsh Pumps**  
185 Progress Road  
Collierville, TN 38017  
PH: (800)888-7167  
FX: (901)860-2323

**Distribution/Service Centers:**  
**Nebraska:** 2599 South Cornhusker Avenue, Hastings, NE 68901 (800)408-7167  
**California:** 3269 East North Building D, Fresno, CA 93725 (800)288-7167  
**Florida:** 2805 Badger Road, Lakeland, FL 33811 (800)444-7167  
**Louisiana:** 1626 Walker Road, Scott, LA 70583 (800)506-7167  
[www.american-marsh.com](http://www.american-marsh.com)