



ITT

Wastewater

Goulds Pumps

Marlow Series Trash Hog II
Self-Priming Solids Handling Centrifugal Pumps

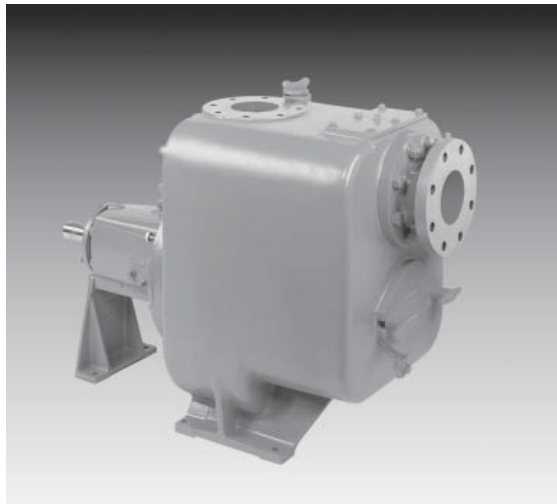

Goulds Pumps is a brand of ITT Corporation.

www.goulds.com

Engineered for life



ITT

GOULDS PUMPS
Wastewater

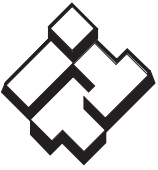

ITT

GOULDS PUMPS Wastewater

TRASH HOG II – A FULL RANGE OF PRODUCT FEATURES

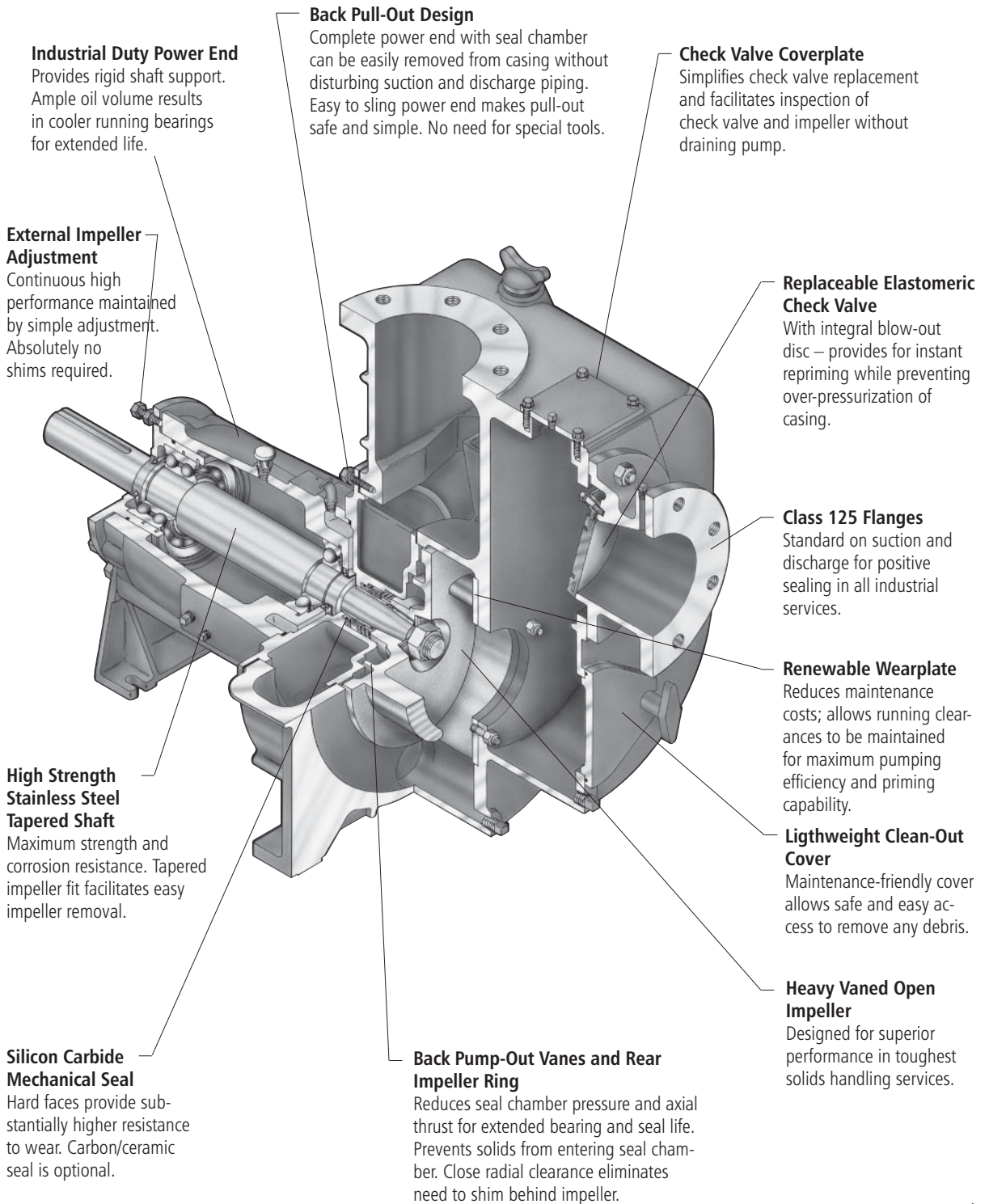

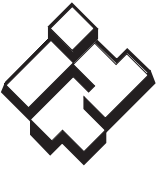

ITT

GOULDS PUMPS
Wastewater

TRASH HOG II PERFORMANCE COVERAGE

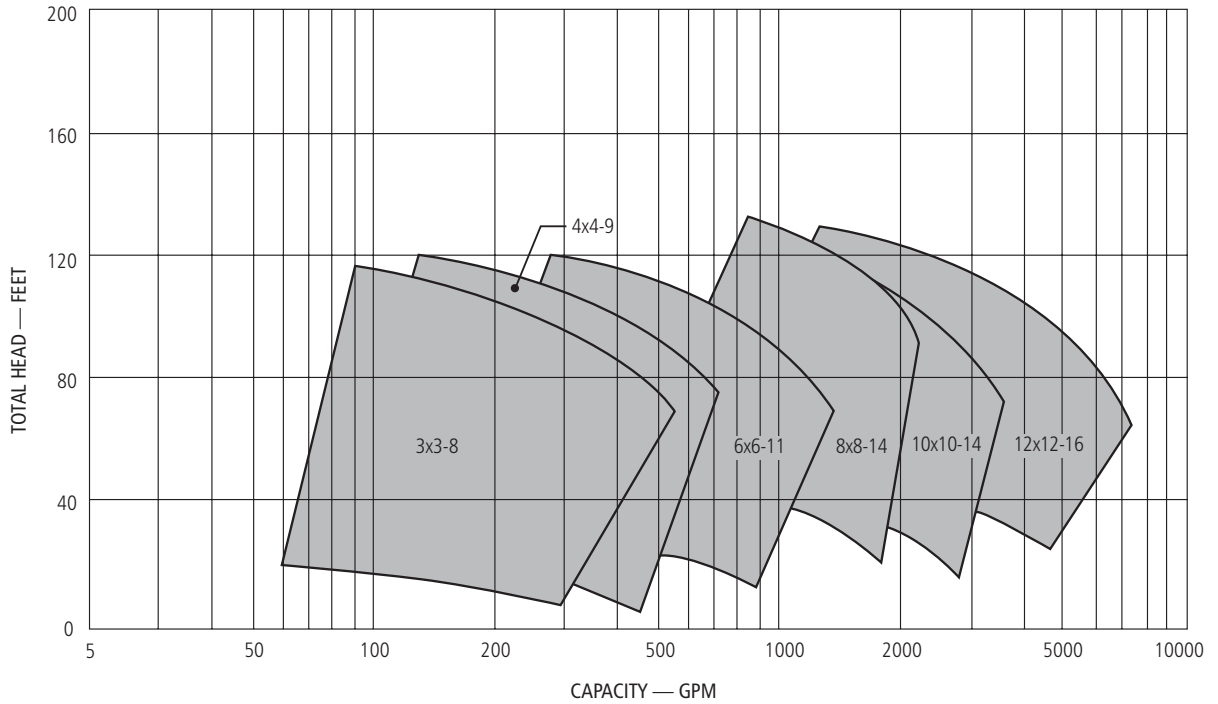

TRASH HOG II SPECIFICATIONS

Pump Size	Flanges 125#		Impeller	Solid Size		Max. Press. PSI	Speed		Static Priming*	
	Inches	cm		Inches	cm		Typical	Maximum	Feet	Meters
3DTHG	3 x 3	7.6 x 7.6	Open	2.50	6.4	85	1750	2400	21	6.4
4DTHG	4 x 4	10.2 x 10.2	Open	3	7.6	85	1750	2400	25	7.6
6ETHG	6 x 6	15.2 x 15.2	Open	3	7.6	85	1750	1750	25	7.6
8GTHG	8 x 8	20.3 x 20.3	Open	3	7.6	65	1150	1450	25	7.6
10GTHG	10 x 10	25.4 x 25.4	Open	3	7.6	65	1150	1450	15	4.6
12GAG	12 x 12	30.5 x 30.5	Open	3	7.6	80	1150	1450	15	4.6

Maximum Temperature: 225 °F (107 °C)

* Based on nominal pipe sizes with 5 feet of horizontal length and 0 discharge at typical speed.

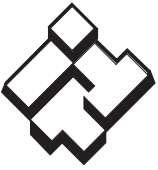

ITT

GOULDS PUMPS Wastewater

TRASH HOG II MATERIALS OF CONSTRUCTION

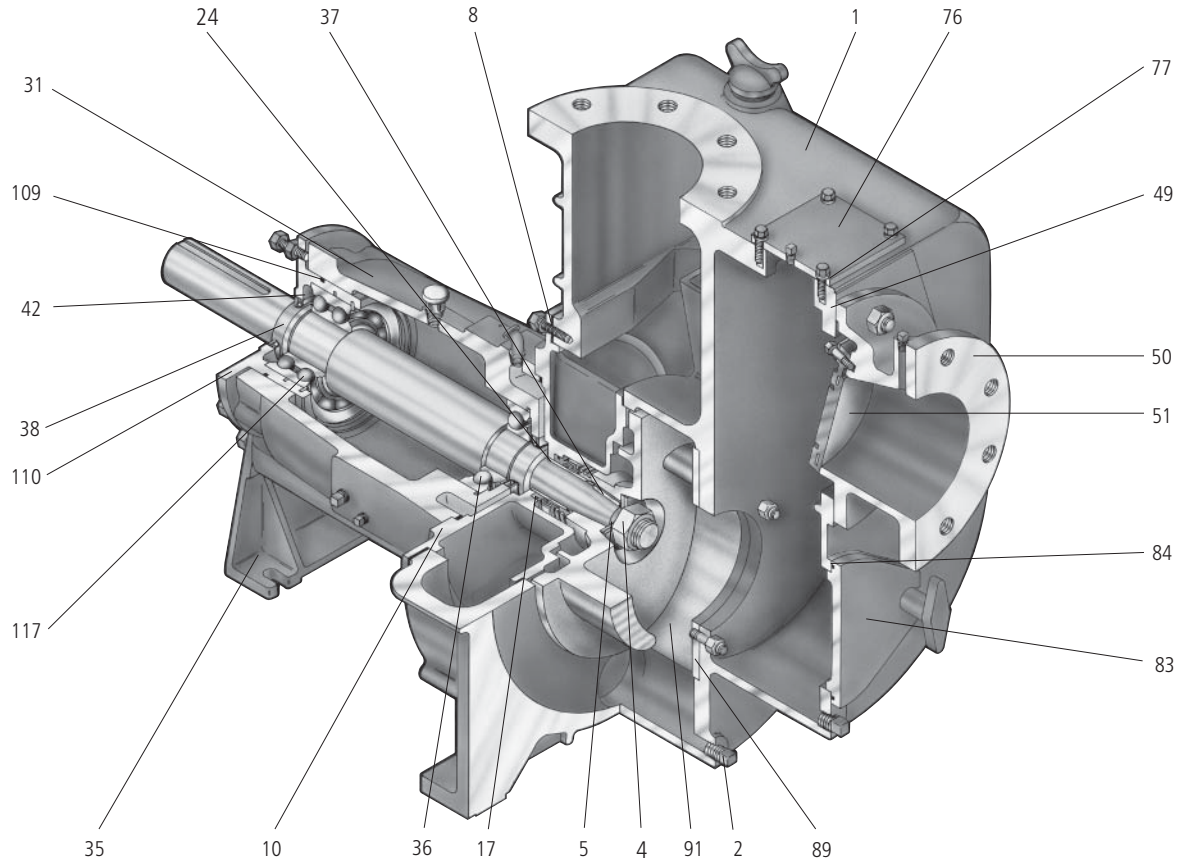

Item No.	Description	Materials
1	Casing	Cast Iron
2	Casing Drain Plug	Carbon Steel
4	Impeller Nut	Carbon Steel
5	Impeller Washer	Carbon Steel
8	Casing Gasket	Lexide
10	Stuffing Box Cover	Cast Iron
17	Mechanical Seal	Single, Type 21 (Silicon Carbide vs. Silicon Carbide)
24	Shaft Sleeve (Optional)	416 SS
31	Bearing Frame	Cast Iron
35	Frame Foot	Cast Iron
36	Radial Bearing	Double Row Angular Contact ⁽¹⁾
37	Impeller Key	Steel
38	Shaft	17-4PH ⁽²⁾

Item No.	Description	Materials
42	Oil Seal	Lip Seal (Buna)Steel
49	Gasket, Suction Piece	Lexide
50	Suction Piece	Cast Iron
51	Check Valve	BUNA-N
76	Inspection Cover	Cast Iron
77	Gasket, Inspection Cover	Lexide
83	Clean Out Cover	Cast Iron
84	O-ring	BUNA-N
89	Wear Plate	Ductile Iron
91	Impeller	Ductile Iron
109	O-ring	BUNA-N
110	Bearing Housing	Cast Iron
117	Thrust Bearing	Double Row Angular Contact ⁽³⁾

⁽¹⁾ Single row bearings standard on 3x3-8, 6x6-11 and 8x8-14 pumps.

⁽²⁾ Carbon steel shaft standard on 3x3-8 and 4x4-1- pumps for all iron construction.

⁽³⁾ Single row bearings standard on 3x3-8 pump.

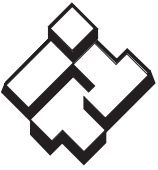

ITT

GOULDS PUMPS Wastewater

TRASH HOG II PERFORMANCE CURVES – 60 HZ

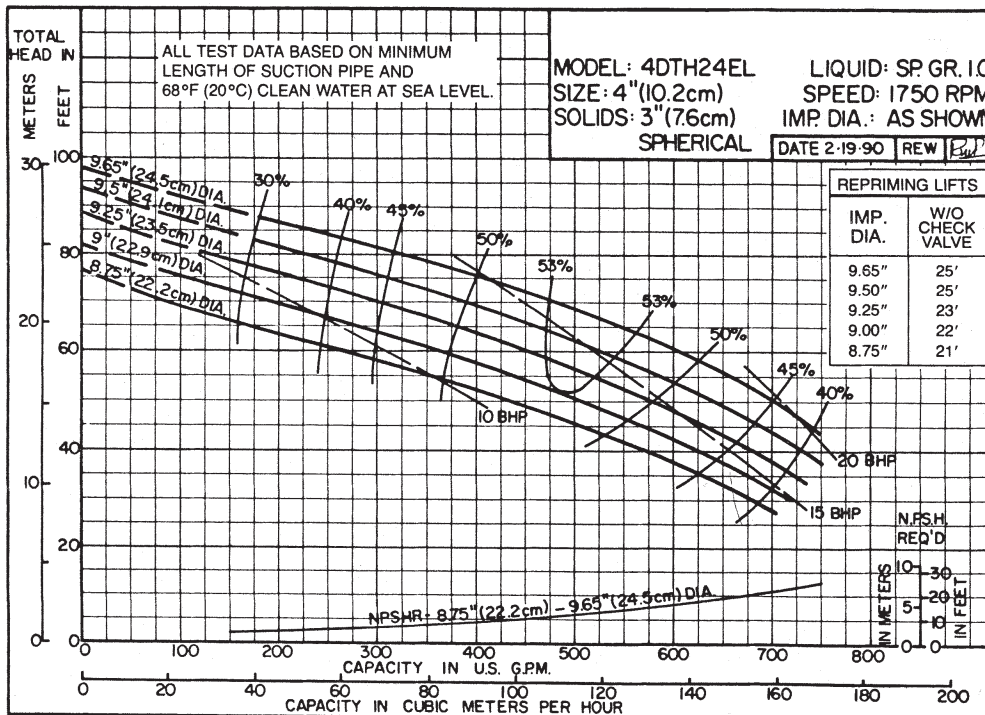
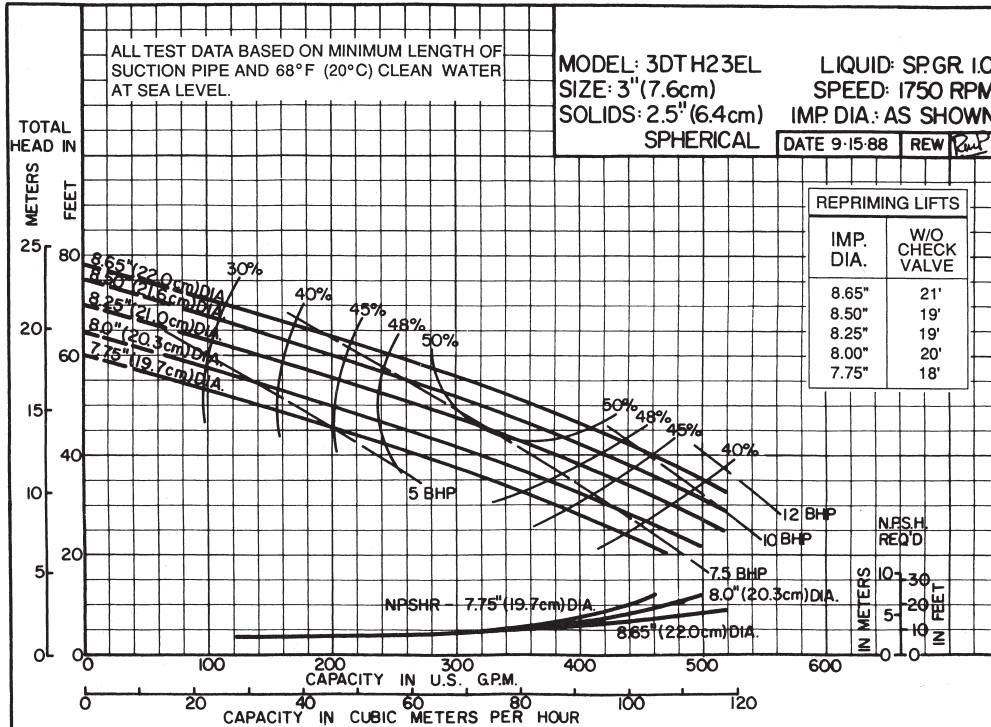

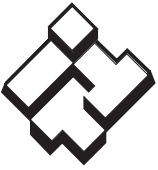

ITT

GOULDS PUMPS
Wastewater

TRASH HOG II PERFORMANCE CURVES – 60 HZ

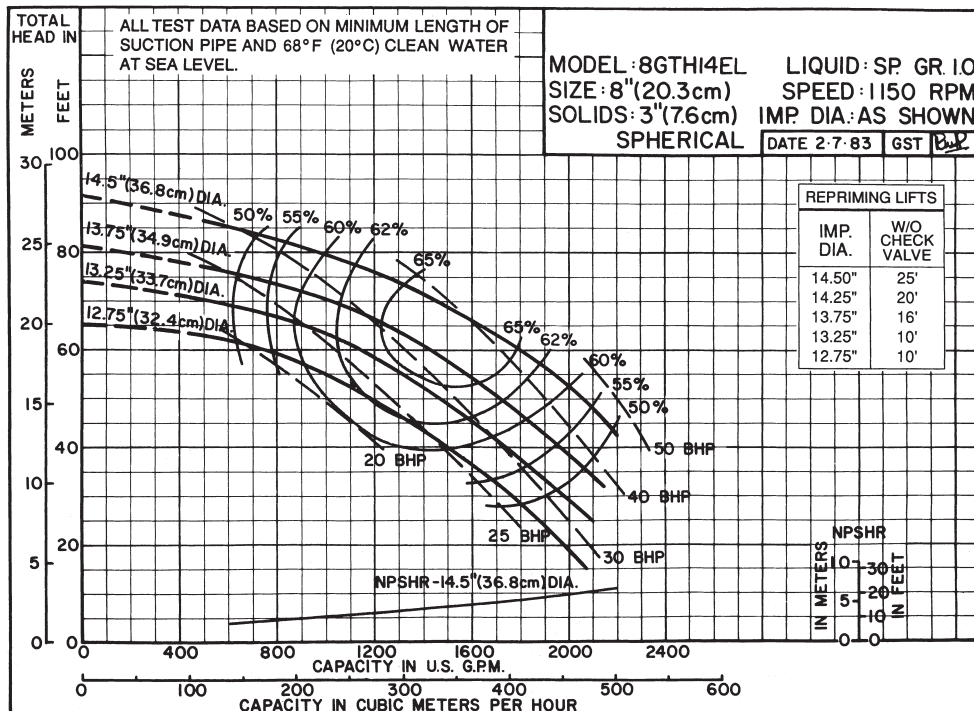
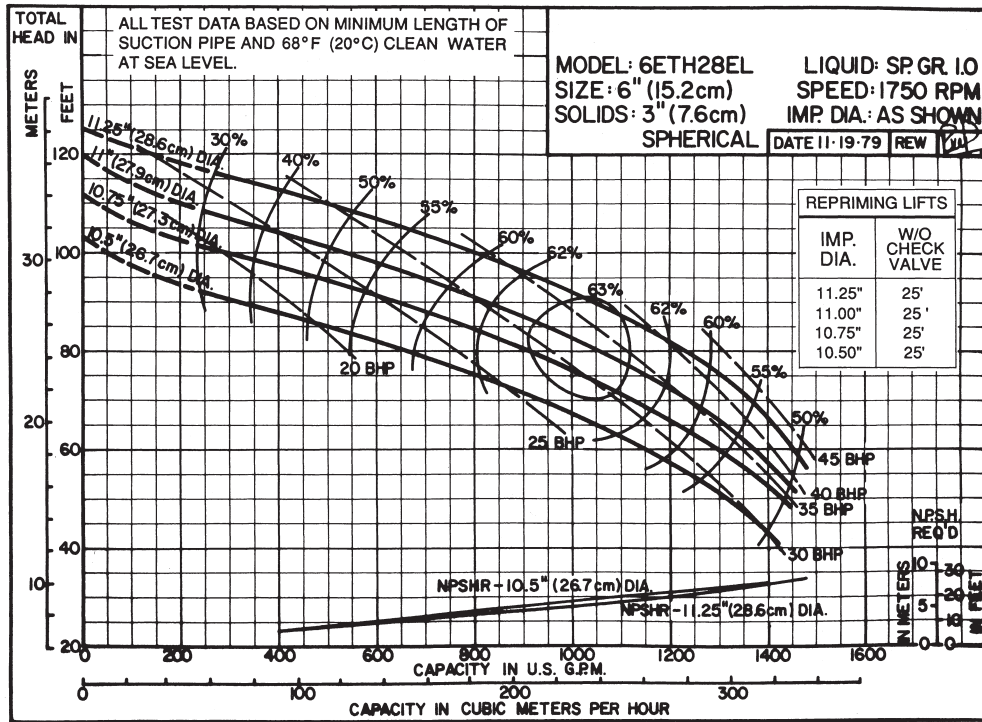



ITT

GOULDS PUMPS Wastewater

TRASH HOG II PERFORMANCE CURVES – 60 HZ

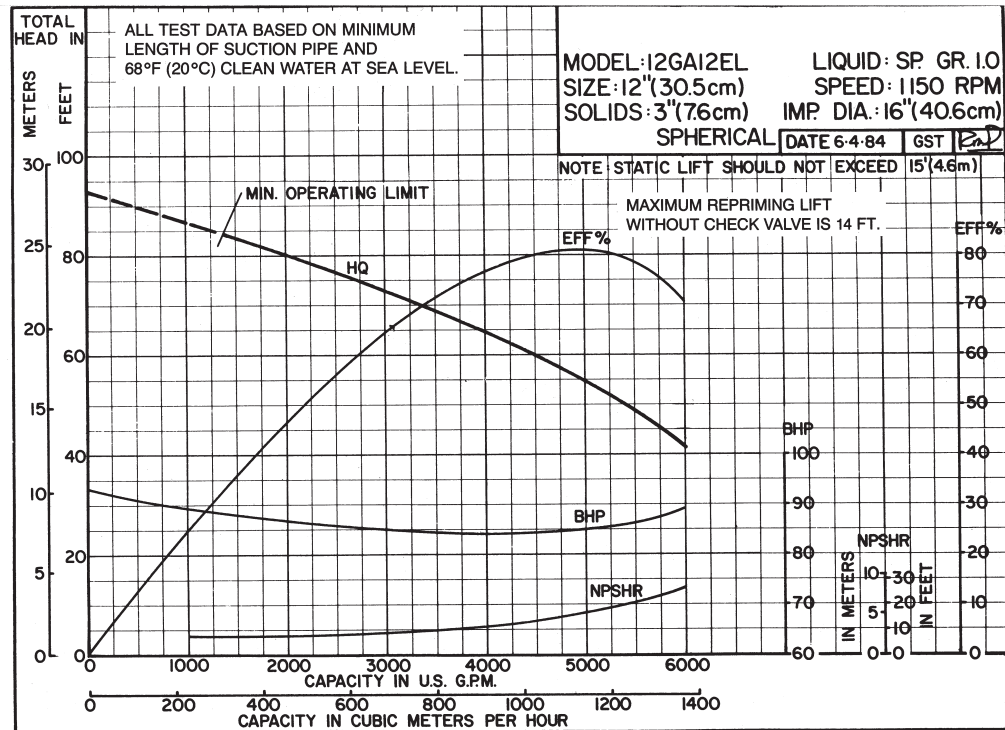
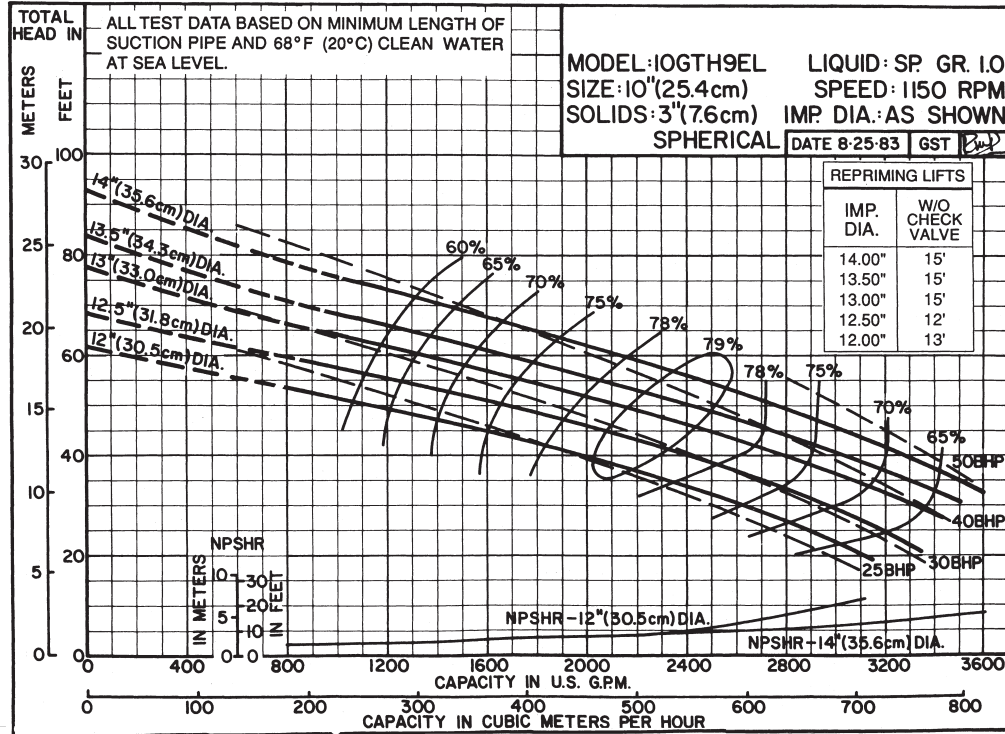

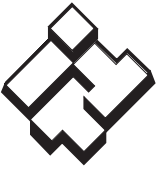

ITT

GOULDS PUMPS Wastewater

TRASH HOG II PERFORMANCE CURVES – 50 HZ

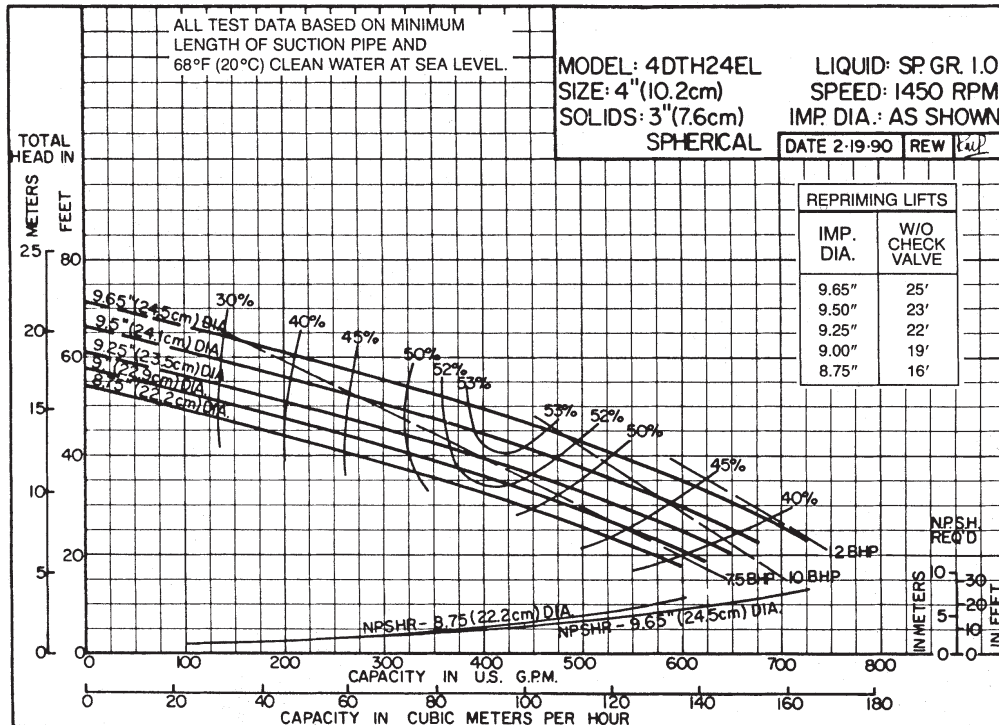
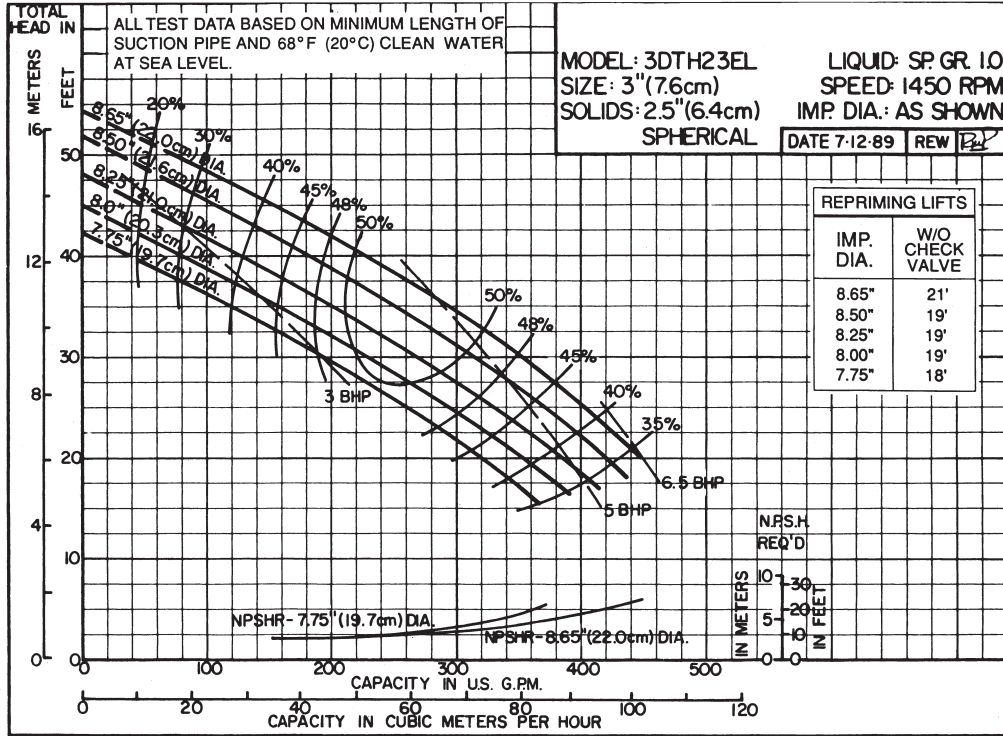

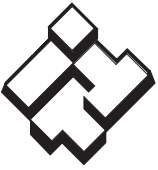

ITT

GOULDS PUMPS
Wastewater

TRASH HOG II PERFORMANCE CURVES – 50 HZ

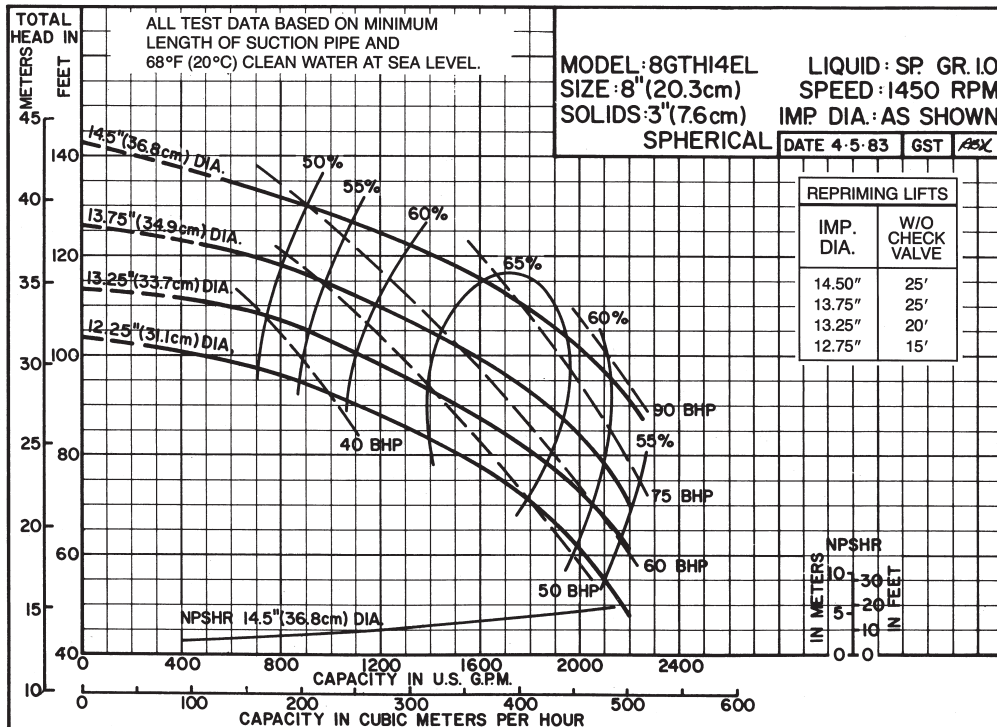
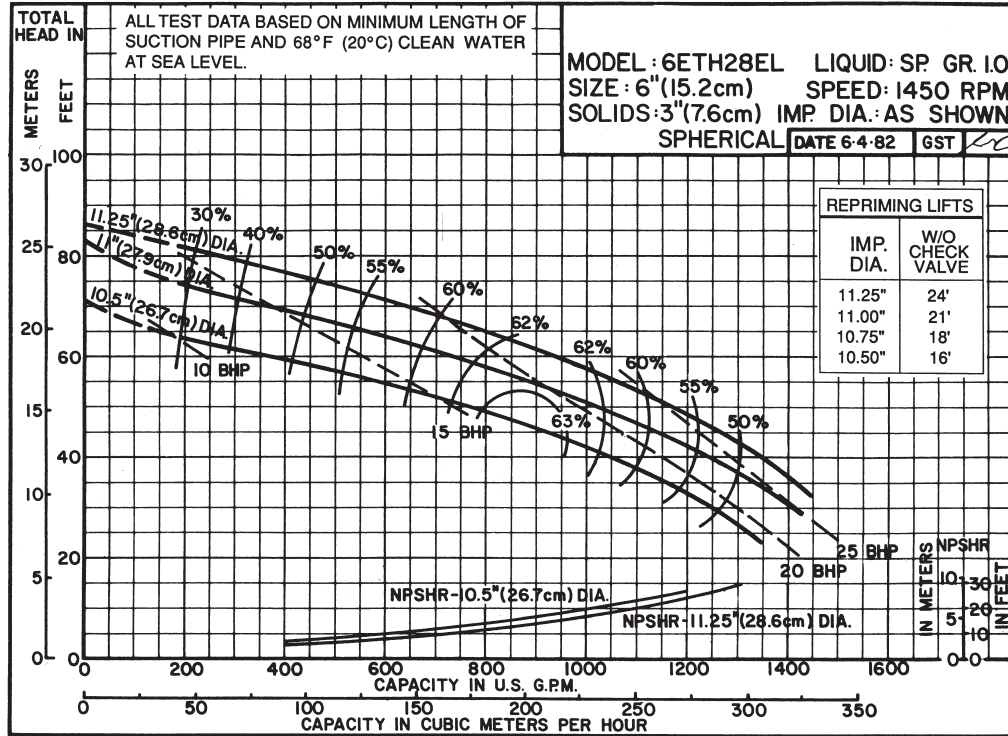

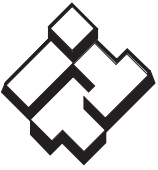

ITT

GOULDS PUMPS Wastewater

TRASH HOG II PERFORMANCE CURVES – 50 HZ

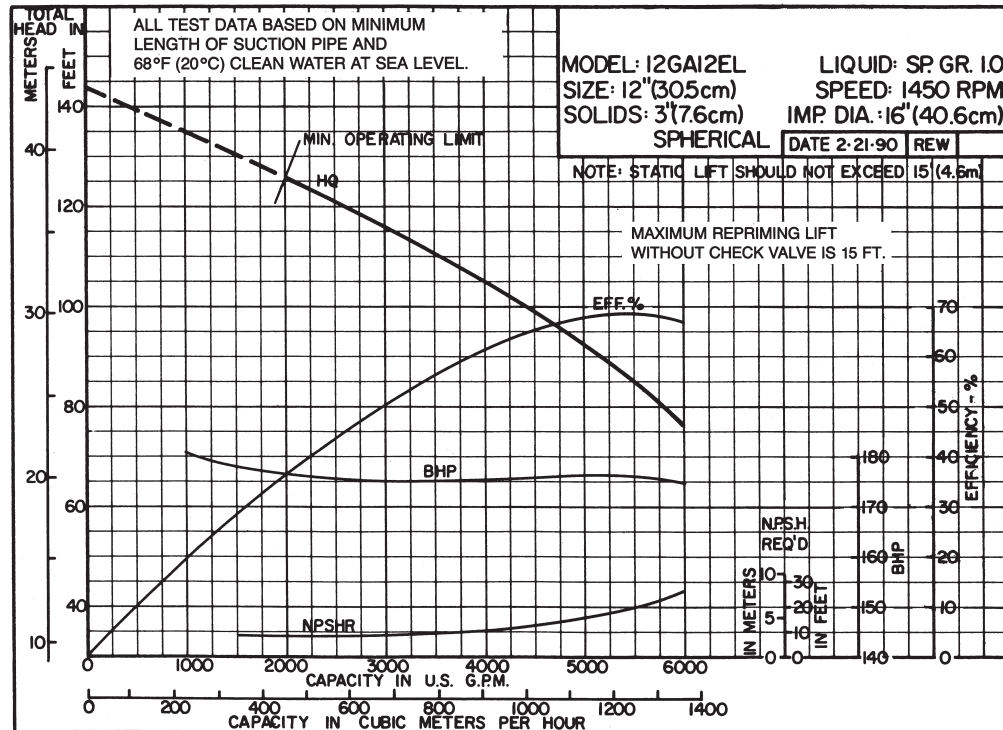
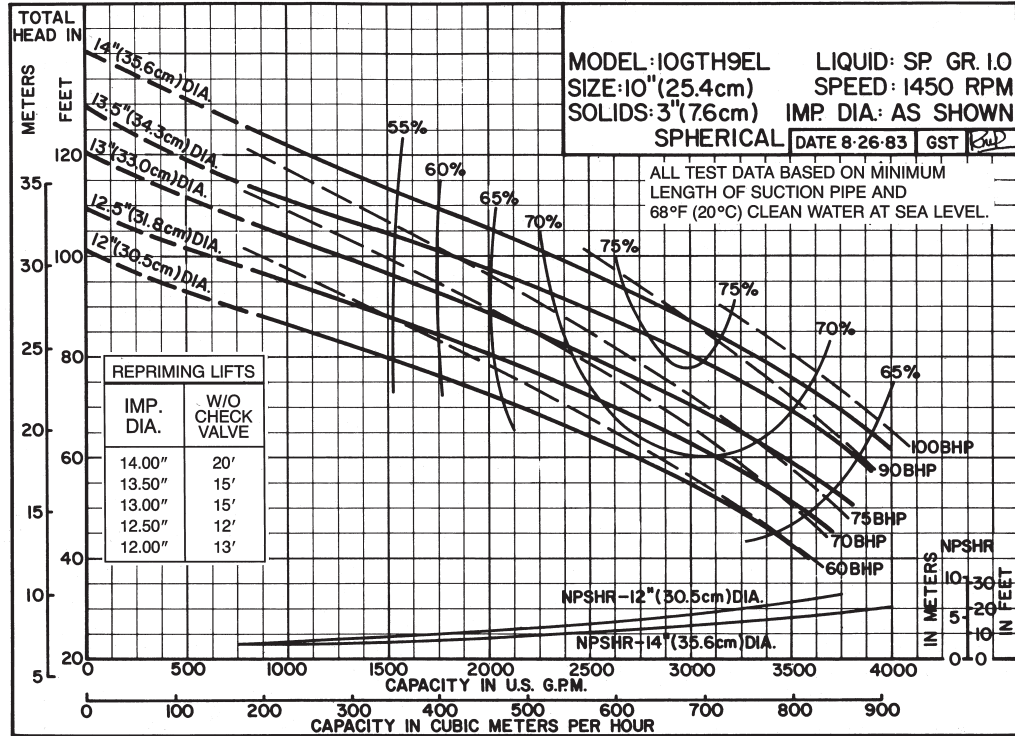

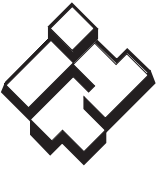

ITT

GOULDS PUMPS Wastewater

TRASH HOG II DIMENSIONS – BARE PUMP

Pump-End Only — 46298

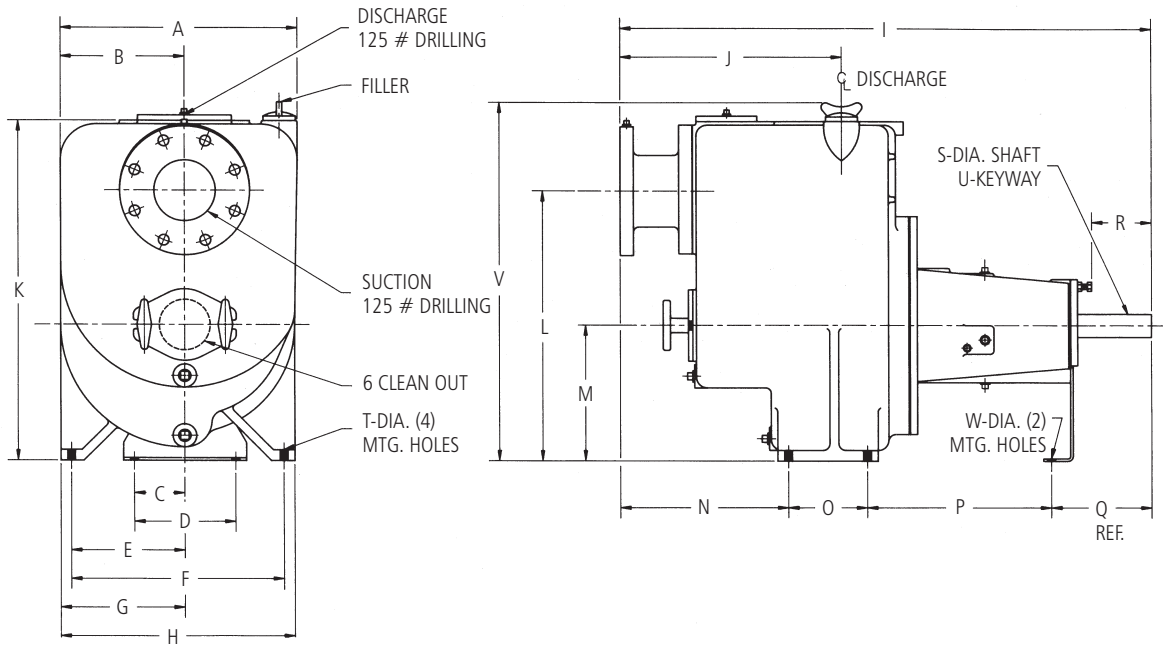

TRASH HOG II — Pump-End Only

Model	Suct.	Disch.	A	B	C	D	E	F	G	H	I	J	K	L	M	N	O	P	Q	R	S	T	U	V	W
M3DTH23EL	3	3	14 ¹ / ₄	7 ⁷ / ₁₆			6	12	6 ¹ / ₁₆	13 ³ / ₈	38 ³ / ₄	17 ³ / ₁₆	25 ⁵ / ₁₆	21 ¹ / ₂	11 ¹ / ₂	10 ¹ / ₁₆	7	14 ⁷ / ₁₆	6 ⁵ / ₈	3 ¹³ / ₁₆	1 ³ / ₈	9 ¹ / ₁₆	5 ⁵ / ₁₆ X 5 ⁵ / ₃₂	26 ⁵ / ₈	
M4DTH24EL	4	4	16 ⁷ / ₁₆	8 ⁵ / ₈	3 ¹ / ₂	7	7 ⁷ / ₈	14 ¹ / ₄	7 ¹³ / ₁₆	15 ⁵ / ₈	40 ⁷ / ₈	18 ⁹ / ₁₆	25 ³ / ₄		11 ¹ / ₂	11 ¹ / ₁₆	9	12 ¹⁵ / ₁₆		1 ⁵ / ₈	9 ¹ / ₁₆	3 ³ / ₈ X 3 ³ / ₁₆	27 ¹ / ₁₆	9 ¹ / ₁₆	
M6ETH28EL	6	6	19 ¹³ / ₁₆	10 ¹ / ₄			8 ³ / ₁₆	16 ³ / ₈	9 ⁵ / ₈	18 ⁹ / ₁₆	42 ¹ / ₁₆	16 ¹ / ₂	27		10	12 ¹ / ₂	6	15 ³ / ₈					28 ⁹ / ₁₆		
M8GTH14EL	8	8	23 ¹ / ₄	10 ⁹ / ₁₆	4 ¹ / ₂	9	9 ¹ / ₄	18 ¹ / ₂	10 ⁷ / ₈	20 ¹ / ₄	45 ⁹ / ₁₆	19 ³ / ₄	34	26 ⁵ / ₈	12	11 ¹ / ₈	13	12 ⁵ / ₈	8 ¹³ / ₁₆	5 ¹³ / ₁₆	2		1 ¹ / ₂ X 1 ¹ / ₄	35 ⁹ / ₁₆	
M10GTH9EL	10	10	28 ¹⁵ / ₁₆	13	6	12	11 ¹ / ₈	22 ¹ / ₄	12 ¹ / ₈	24 ¹ / ₄	54 ¹ / ₈	25 ⁵ / ₈	44	33 ¹ / ₂	14 ³ / ₄	16	14	15 ⁵ / ₁₆					45 ⁵ / ₁₆	1 ¹ / ₁₆	

Dimensions in inches. Do not use for construction purposes without formal factory approval.
 Goulds Pumps reserves the right to make changes in design, materials, and prices without notice.

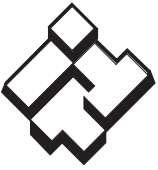

ITT

GOULDS PUMPS Wastewater

TRASH HOG II DIMENSIONS – WITH BEDPLATE

Long Coupled — 46299

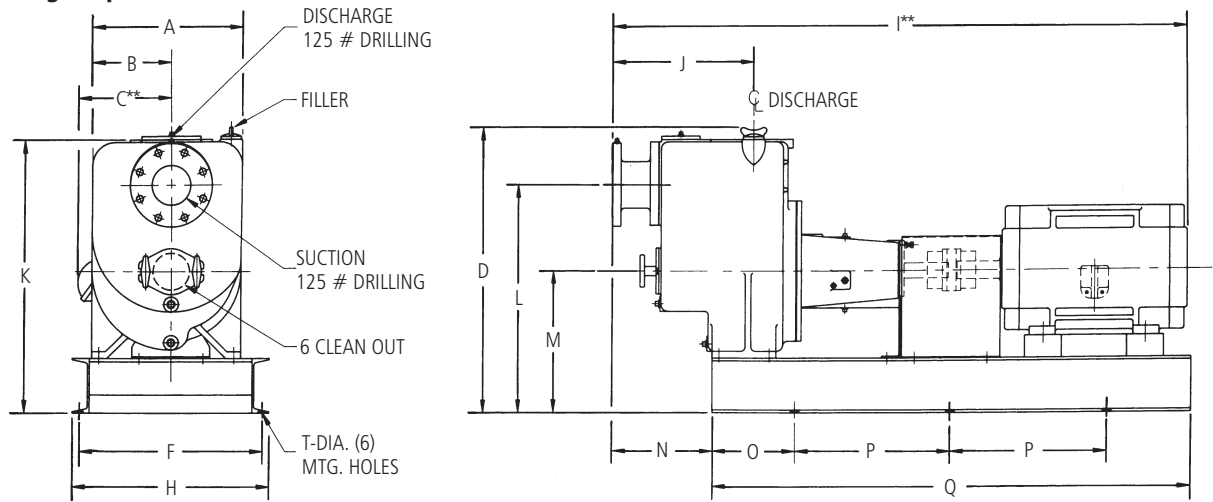

** These dimensions are based on open motors and may vary depending on motor manufacturer.

TRASH HOG II — Long-Coupled

Model	Suct.	Disch.	Frame	A	B	C	D	F	H	I	J	K	L	M	N	O	P	Q	T	Spacer Coupling			
																				I	Q		
M3DTH23EL	3	3	184T	14 ¹ / ₄	7 ⁹ / ₁₆	6 ⁵ / ₁₆	29 ⁵ / ₈	18	19 ¹ / ₂	53 ³ / ₄	17 ³ / ₁₆	28 ⁵ / ₁₆	24 ¹ / ₂			9 ⁷ / ₁₆	8		43		57 ¹ / ₂	47	
			213T			7 ⁹ / ₁₆				55 ¹ / ₄											46	59 ³ / ₈	50
			215T			8 ¹⁵ / ₁₆				56 ³ / ₄											51	60 ⁷ / ₈	55
			254T			60 ³ / ₁₆				51											64 ³ / ₁₆	55	
M4DTH24EL	4	4	213T	16 ⁷ / ₁₆	8 ⁵ / ₈	7 ⁹ / ₁₆	30 ¹ / ₁₆	20	21 ¹ / ₂	56 ¹ / ₂	18 ⁹ / ₁₆	28 ³ / ₄	24	14 ¹ / ₂	10 ⁹ / ₁₆	10		15	46		60 ⁵ / ₈	50	
			215T			8 ¹⁵ / ₁₆				58											51	62 ¹ / ₈	55
			254T			11 ⁹ / ₁₆				61 ¹ / ₁₆											51	65 ⁷ / ₁₆	55
			256T			60 ³ / ₁₆				51											67 ³ / ₁₆	55	
M6ETH28EL	6	6	254T	19 ¹³ / ₁₆	10 ¹ / ₄	8 ¹⁵ / ₁₆	32 ⁵ / ₁₆	22	23 ¹ / ₂	64	16 ¹ / ₂	30 ³ / ₄	24 ³ / ₄	13 ³ / ₄	11 ¹ / ₂	8 ¹ / ₄	18	52 ¹ / ₂			68	56 ¹ / ₂	
			256T			11 ⁹ / ₁₆				65 ³ / ₄											52 ¹ / ₂	69 ³ / ₄	56 ¹ / ₂
			284T			11 ⁹ / ₁₆				67 ¹ / ₁₆											54 ¹ / ₂	71 ¹ / ₁₆	58 ¹ / ₂
			286T			11 ⁹ / ₁₆				68 ⁹ / ₁₆											54 ¹ / ₂	72 ⁹ / ₁₆	58 ¹ / ₂
			324T			13 ⁵ / ₈				70 ⁷ / ₈											57 ¹ / ₂	73 ⁵ / ₈	61
			326T			13 ⁵ / ₈				71 ⁵ / ₈											57 ¹ / ₂	75 ⁵ / ₈	61
M8GTH14EL	8	8	324T	23 ¹ / ₄	10 ⁹ / ₁₆	39 ⁹ / ₁₆	40 ⁹ / ₁₆	24	25 ³ / ₄	73	19 ³ / ₄	38	30 ⁵ / ₈	16	10 ⁷ / ₈	7	24	62			76 ¹ / ₂	65 ¹ / ₂	
			326T			15 ⁵ / ₈				74 ¹ / ₂											63	78	66
			364T			15 ⁵ / ₈				75 ⁵ / ₈											63	79 ¹ / ₄	66
			365T			15 ⁵ / ₈				76 ⁵ / ₈											63	80 ¹ / ₄	66
M10GTH9EL	10	10	324T	28 ¹⁵ / ₁₆	13	49 ⁵ / ₁₆	49 ⁵ / ₁₆	30	31 ³ / ₄	81 ¹ / ₁₆	25 ⁵ / ₈	48	37 ¹ / ₂	18 ³ / ₄	14	7 ¹ / ₂	26	67			85 ⁹ / ₁₆	70	
			326T			81 ¹ / ₁₆				67											86 ⁹ / ₁₆	71	
			364T			83 ¹ / ₁₆				67											87 ¹³ / ₁₆	71	
			365T			84 ⁷ / ₁₆				67											88 ¹³ / ₁₆	71	

Dimensions in inches. Do not use for construction purposes without formal factory approval.
 Goulds Pumps reserves the right to make changes in design, materials, and prices without notice.

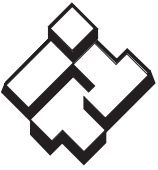

ITT

GOULDS PUMPS Wastewater

TRASH HOG II DIMENSIONS – MODEL 12 GA12EL

Bare Pump — 44967 B

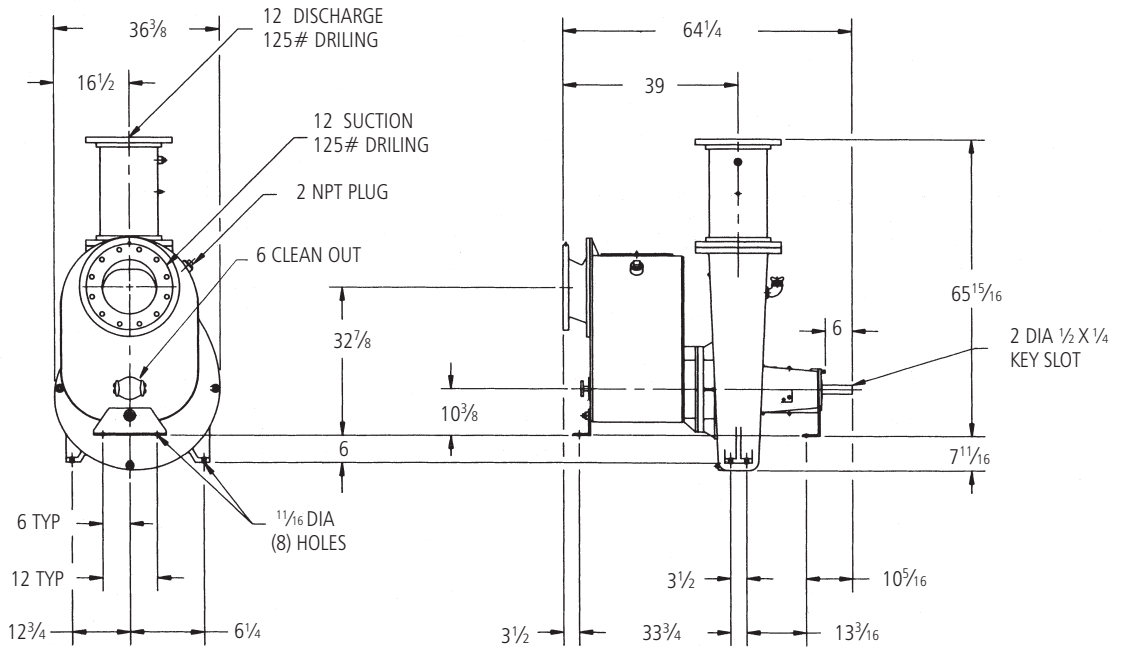

With Bedplate — 44968 B

HP	RPM	FRAME	A*	B	C*
40	850	365T	95 ⁹ / ₁₆	90	15 ⁵ / ₈
100	1150	444T	103 ⁷ / ₈	97	22 ³ / ₁₆

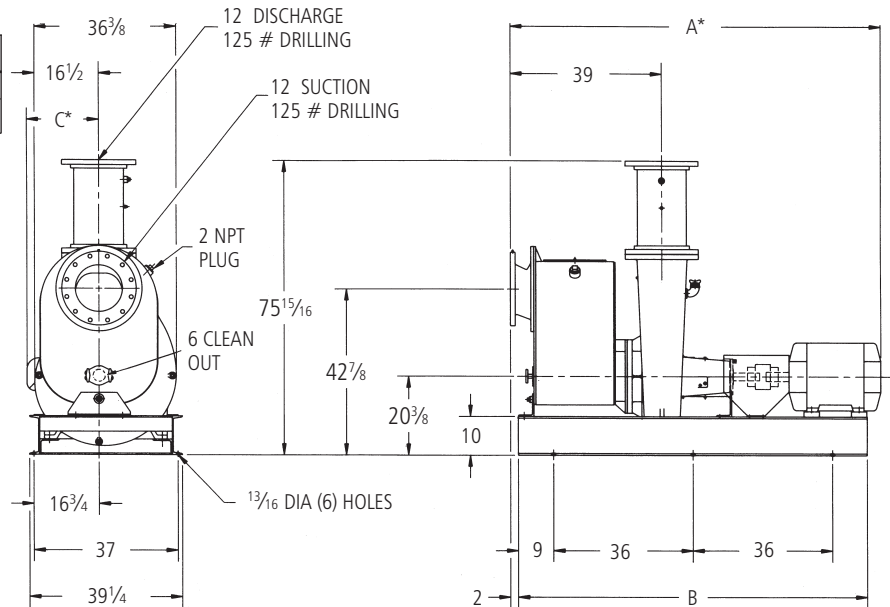

Dimensions in inches. Do not use for construction purposes without formal factory approval.
 Goulds Pumps reserves the right to make changes in design, materials, and prices without notice.
 * These dimensions are approximate depending on motor manufacturer.



ITT

GOULDS PUMPS
Wastewater

NOTES



ITT

Wastewater

TYPICAL APPLICATIONS

- Sewage Lift Station
- Sump
- Waste Treatment
- Settling Ponds
- Waste Water
- Sludge

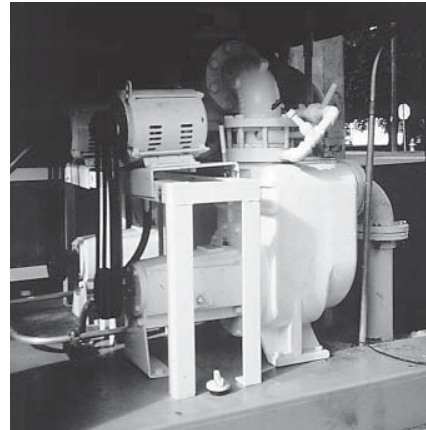

**Sewage
Lift Station**

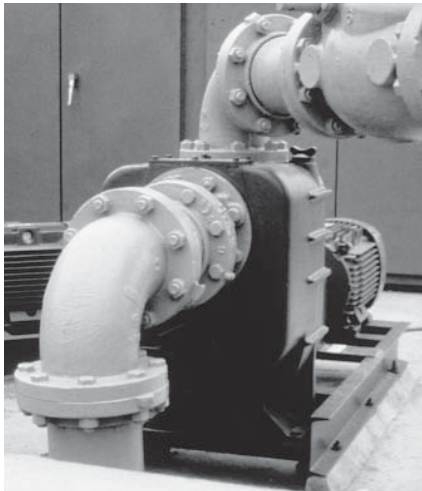

**Waste
Treatment**

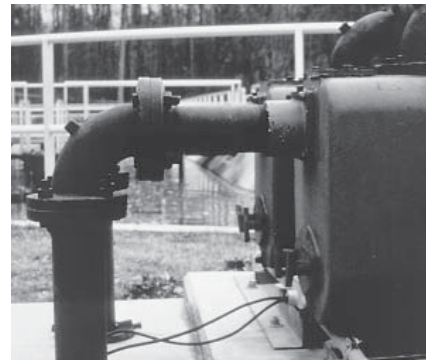

Settling Pond

 **GOULDS PUMPS**

Goulds Pumps and the ITT Engineered Blocks Symbol are registered trademarks and tradenames of ITT Corporation.

SPECIFICATIONS ARE SUBJECT TO CHANGE WITHOUT NOTICE.

MG2000 April, 2007
© 2007 ITT Corporation

Engineered for life