

ANTICO

non metallic pumps



MKNS Series - Lined Magnetic Drive Pumps

ANTICO

MKNS SERIES

A trend that is emerging is that chemical pumps for corrosive, toxic or bromine-containing liquids are subject to strict standards when it comes to safety, leaks to the atmosphere and service life. These high requirements are the reasons for trend towards seal-less in particularly, magnetic drive pumps.

ANTICO Lined Magnetic Drive Pumps are designed as per ISO 2858 standard with PFA-P linings. PFA-P linings give improved corrosion resistance as compared to high alloy, expensive metals magnetic drive pumps.

PFA-P stands for Perfluoroalkoxy Permeation Grade. PFA-P is processed in a transfer moulding operation and as a result the lining wall thicknesses can be accurately defined and reproduced. Thanks to its dense molecular structure, PFA-P has generally much lower permeation rates than PTFE with the same wall thicknesses, but it has the same chemical and thermal resistance properties. PFA-P is justifiably the material of first choice in applications with media which especially tend to permeate, such as chlorine, bromine or fluorine compounds.

If the chemical penetrates the lining, this may cause corrosion on the pressure-bearing metal body and perhaps even failure of the unit. MKNS Lined Magnetic Drive Pumps have PFA-P lining wall thickness to 6-9 mm producing substantially longer service lives.



Applications:

MKNS Series are best suited for pumping corrosive and toxic media such as chlorine, bromine or fluorine compounds.

Design Features

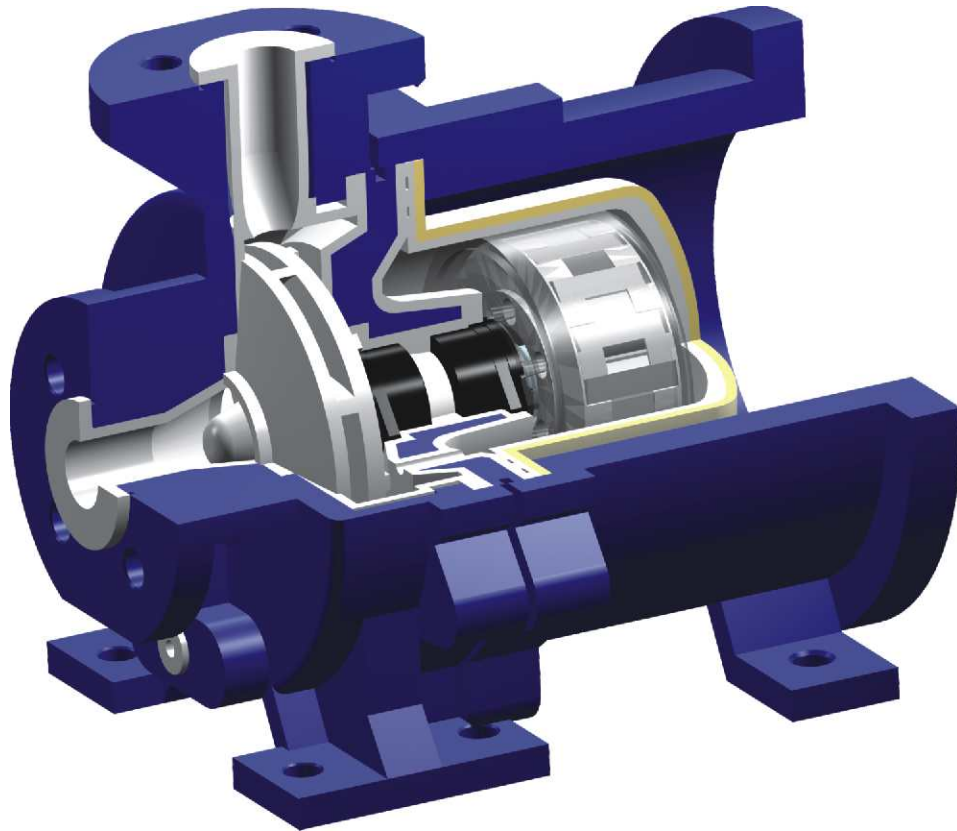

- 1** Volute Casing Top centerline discharge, lined with PFA-P. Minimum lining thickness of 6 mm, lining locked by multiple locking grooves. Outer body ductile iron, other materials like stainless steel available on request.



- 4** Shaft PFA-P lined solid stainless steel.



- 2** Impeller All impellers precision moulded in PFA-P, light in weight, closed construction. Closed impellers result in lower power requirements and higher efficiencies.



- 5** Magnetic Coupling Power transmitted to the pump by high quality samarium cobalt magnet. Product side wetted rotor is PFA-P lined.



- 3** Bearings Impeller, Shaft and Magnetic Rotor are mounted on Sintered Silicon Carbide Bearings lubricated by process media via internal grooves. Bearings withstand brief dry running and lack of lubrication.



- 6** Isolation Shell Made from PVDF / carbon fibre reinforced plastic (CFRP) with PFA-P inner shell is free from Eddy Currents thus prevents additional heating of the Pumping Media.



Magnetic Drive Pump Overview

In a standard centrifugal pump, the power is delivered to the pump end either through a direct connection between the rotating element and the motor shaft or through a coupling between the pump end shaft and the motor shaft.

In these cases, the pumping chamber needs to be sealed from the outside. Traditionally, packing or some other sort of mechanical seal accomplishes this.

The principle of a magnetic drive pump is that the rotation from the motor shaft is transferred to the pump end via a magnetic coupling which eliminates the need for the shaft seal or packing.

A drive magnet is mounted to the motor shaft, which transfers the motor torque through a sealed housing to an internal driven magnet. The driven magnet is coupled directly to the impeller. This configuration is categorized as seal-less.

The following will give an idea of approximate leakage rate for various Sealing arrangements:

Gland Packing	> 1000 ppm
Single Mechanical Seal	10 - 1000 ppm
Double Mechanical Seal	< 10 ppm
Sealless	0 ppm

Lined Magnetic Drive Pump Offers Several Advantages:

1. **Improved Corrosion Resistance** Outer Body in Ductile Iron give rigidity to handle pump internal pressure and nozzle loads. PFA lining provides improved corrosion resistance.
2. **Lower Initial Costs** Significant factor while considering metallurgies like Hastalloy or Titanium
3. **Zero Eddy Current Losses** Power losses due to electrical currents produced by the rotating lines of magnetic flux cutting through a stationary conductor. These power losses translate into heat which is transferred to the pumping media.

In case of metal shells, these losses could range from 10-20% of magnetic drive rating.

For Non-Conductive shells, this is not observed since no eddy currents are generated.

4. **Enhanced Dry Running Performance** Dry running more precisely "Broken Prime" may occur for transfer or unloading services, means there is enough liquid in the pump to lubricate the Silicon Carbide Bearings which are essentially "Product Lubricated" Because the heat input is low, Dry Running could be sustained for short periods.
5. **Close Coupled Design** Outer magnet directly mounted on Motor shaft which does not require a separate pump bearing frame. This eliminates the need for coupling alignment allowing much shorter overall length.

Performance Range Chart

Pump Dimensions & Connections

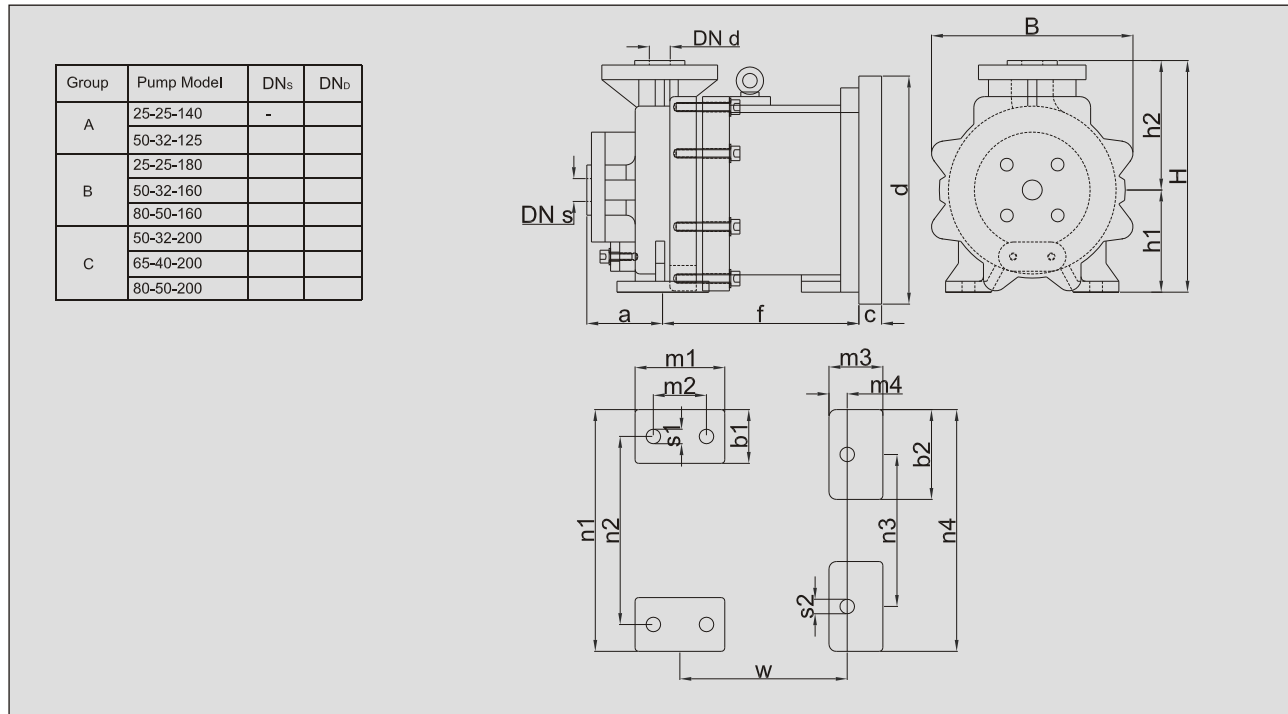

Pump dimensions

Pump Model	DN s	DN d	a	B	f	H	h1	h2	b1	b2	m1	m2	m3	m4	n1	n2	n3	n4	S1	S2	W
25-25-140	25	25	80	222	218	254	112	142	50	50	100	70	43	22	190	140	140	190	14	14	177
50-32-125	50	32																			
25-25-180	25	25																			
50-32-160	50	32							50												
80-50-160	80	50																			
50-32-200	50	32																			
65-40-200	65	40																			
80-50-200	80	50																			

Motor mounting Plate

ICE-MOTOR	80 B5	90 B5	100 B5	112 B5	132 B5	80 B5	90 B5	100 B5	112 B5	132 B5	160 B5/B35 *	100 B5	112 B5	132 B5	160 B5/B35 *	180 B35	200 B35
c			25														
d			250														
Group	A					B					C						



Anticorrosive Equipment Pvt Ltd

15, Hind Service Industries, 2nd Floor,
Off V. S. Road, Shivaji Park, Mumbai - 400 028, India
Phone : +91 22 2446 6496, 2446 8340, 2445 3501
Fax : +91 22 2444 9271
info@anticopumps.co.in www.anticopumps.co.in

